

Automotive rail-to-rail 1.8 V high-speed comparator

Datasheet - production data

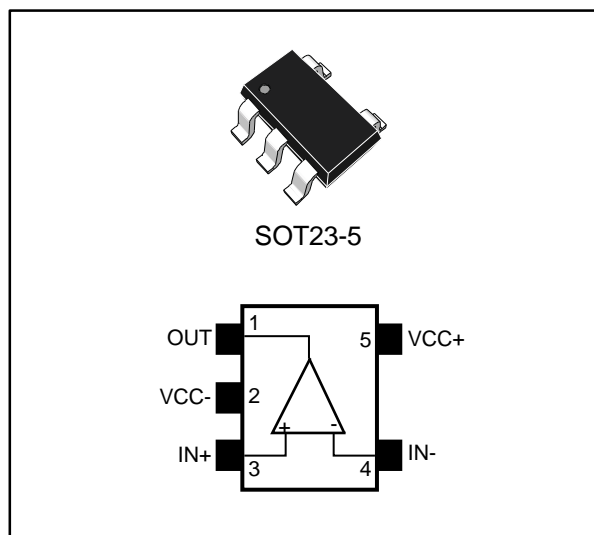

Related products

- TS3021 for standard temperature range (-40 °C to 125 °C)

Applications

- Automotive
- Telecom
- Instrumentation
- Signal conditioning
- High-speed sampling systems
- Portable communication systems

Description

The TS3021H single comparator features high-speed response time with rail-to-rail inputs. With a supply voltage specified from 2 to 5 V, this comparator can operate over a wide temperature range: -40 °C to 150 °C.

The TS3021H comparator offers micropower consumption as low as a few tens of microamperes thus providing an excellent ratio of power consumption current versus response time.

The TS3021H includes push-pull outputs and is available in the small SOT23-5 package.

Features

- AEC-Q100 and Q003 qualified
- Extended temperature range: -40 °C to 150 °C
- Propagation delay: 38 ns
- Low current consumption: 73 µA
- Rail-to-rail inputs
- Push-pull outputs
- Supply operation from 1.8 to 5 V
- High ESD tolerance: 5 kV HBM, 300 V MM
- Latch-up immunity: 200 mA
- SMD package



Contents

1	Absolute maximum ratings and operating conditions	3
2	Electrical characteristics	4
3	Package information	15
	3.1 SOT23-5 package information	16
4	Ordering information.....	17
5	Revision history	18

1 Absolute maximum ratings and operating conditions

Table 1: Absolute maximum ratings (AMR)

Symbol	Parameter	Value	Unit
V _{CC}	Supply voltage, V _{CC} = (V _{CC+}) - (V _{CC-}) ⁽¹⁾	5.5	V
V _{ID}	Differential input voltage ⁽²⁾	±5	
V _{IN}	Input voltage range	(V _{CC-}) - 0.3 to (V _{CC+}) + 0.3	
I _{IN}	Input current ⁽³⁾	10	mA
R _{thja}	Thermal resistance junction-to-ambient ⁽⁴⁾	250	°C/W
R _{thjc}	Thermal resistance junction-to-case ⁽⁴⁾	81	
T _{stg}	Storage temperature	-65 to 160	°C
T _j	Junction temperature	160	
T _{LEAD}	Lead temperature (soldering 10 s)	260	
ESD	HBM: human body model ⁽⁵⁾	5000	V
	CDM: charged device model ⁽⁶⁾	1500	
	Latch-up immunity	200	mA

Notes:

⁽¹⁾All voltage values, except the differential voltage, are referenced to (V_{CC-})

⁽²⁾The magnitude of the input and output voltages must never exceed the supply rail ±0.3 V

⁽³⁾The input current must be limited by a resistor in series with the inputs.

⁽⁴⁾Short circuits can cause excessive heating. These values are typical

⁽⁵⁾Human body model: a 100 pF capacitor is charged to the specified voltage, then discharged through a 1.5 kΩ resistor between two pins of the device. This is done for all couples of connected pin combinations while the other pins are floating.

⁽⁶⁾Charged device model: all pins and the package are charged together to the specified voltage and then discharged directly to the ground through only one pin. This is done for all pins.

Table 2: Operating conditions

Symbol	Parameter	Value	Unit	
V _{CC}	Supply voltage	0 °C < T _{amb} < 150 °C	1.8 to 5	V
		-40 °C < T _{amb} < 150 °C	2 to 5	
V _{icm}	Common-mode input voltage range	-40 °C < T _{amb} < 85 °C	(V _{CC-}) - 0.2 to (V _{CC+}) + 0.2	
		85 °C < T _{amb} < 150 °C	(V _{CC-}) to (V _{CC+})	
T _{oper}	Operating temperature range	-40 to 150	°C	

2 Electrical characteristics

Table 3: Electrical characteristics at $V_{CC} = 2\text{ V}$, $T_{amb} = 25\text{ °C}$, and full V_{icm} range (unless otherwise specified)

Symbol	Parameter	Test conditions ⁽¹⁾	Min.	Typ.	Max.	Unit
V_{IO}	Input offset voltage	T_{amb}		0.5	6	mV
		$-40\text{ °C} < T_{amb} < 150\text{ °C}$		0.5	7	
$\Delta V_{IO}/\Delta T$	Input offset voltage drift	$-40\text{ °C} < T_{amb} < 150\text{ °C}$		3	20	$\mu\text{V}/\text{°C}$
I_{IO}	Input offset current ⁽²⁾	T_{amb}		1	20	nA
		$-40\text{ °C} < T_{amb} < 150\text{ °C}$			100	
I_{IB}	Input bias current ⁽²⁾	T_{amb}		86	160	nA
		$-40\text{ °C} < T_{amb} < 150\text{ °C}$			300	
I_{CC}	Supply current	No load, output high, $V_{icm} = 0\text{ V}$		73	90	μA
		No load, output high, $V_{icm} = 0\text{ V}$, $-40\text{ °C} < T_{amb} < 150\text{ °C}$			115	
		No load, output low, $V_{icm} = 0\text{ V}$		84	105	
		No load, output low, $V_{icm} = 0\text{ V}$, $-40\text{ °C} < T_{amb} < 150\text{ °C}$			125	
I_{SC}	Short-circuit current	Source		9		mA
		Sink		10		
V_{OH}	Output voltage high	$I_{source} = 1\text{ mA}$	1.88	1.92		V
		$-40\text{ °C} < T_{amb} < 150\text{ °C}$	1.79			
V_{OL}	Output voltage low	$I_{sink} = 1\text{ mA}$		60	100	mV
		$-40\text{ °C} < T_{amb} < 150\text{ °C}$			170	
CMRR	Common-mode rejection ratio	$0 < V_{icm} < 2\text{ V}$		67		dB
SVR	Supply voltage rejection	$\Delta V_{CC} = 2\text{ to }5\text{ V}$, $V_{icm} = 0\text{ V}$	58	73		
T_{PLH}	Propagation delay, low to high output level ⁽³⁾	$V_{icm} = 0\text{ V}$, $f = 10\text{ kHz}$, $CL = 50\text{ pF}$, overdrive = 100 mV		38	60	ns
		$V_{icm} = 0\text{ V}$, $f = 10\text{ kHz}$, $CL = 50\text{ pF}$, overdrive = 100 mV, $-40\text{ °C} < T_{amb} < 150\text{ °C}$			120	
		$V_{icm} = 0\text{ V}$, $f = 10\text{ kHz}$, $CL = 50\text{ pF}$, overdrive = 20 mV		48	75	
		$V_{icm} = 0\text{ V}$, $f = 10\text{ kHz}$, $CL = 50\text{ pF}$, overdrive = 20 mV, $-40\text{ °C} < T_{amb} < 150\text{ °C}$			140	

Symbol	Parameter	Test conditions ⁽¹⁾	Min.	Typ.	Max.	Unit
T _{PHL}	Propagation delay, high to low output level ⁽⁴⁾	V _{icm} = 0 V, f = 10 kHz, CL = 50 pF, overdrive = 100 mV		40	60	ns
		V _{icm} = 0 V, f = 10 kHz, CL = 50 pF, overdrive = 100 mV, -40 °C < T _{amb} < 150 °C			120	
		V _{icm} = 0 V, f = 10 kHz, CL = 50 pF, overdrive = 20 mV		49	75	
		V _{icm} = 0 V, f = 10 kHz, CL = 50 pF, overdrive = 20 mV, -40 °C < T _{amb} < 150 °C			140	
T _F	Fall time	f = 10 kHz, CL = 50 pF, RL = 10 kΩ, overdrive = 100 mV		8		
T _R	Rise time	f = 10 kHz, CL = 50 pF, RL = 10 kΩ, overdrive = 100 mV		9		

Notes:

⁽¹⁾All values over the temperature range are guaranteed through correlation and simulation. No production test is performed at the temperature range limits.

⁽²⁾Maximum values include unavoidable inaccuracies of the industrial tests.

⁽³⁾Response time is measured 10%/90% of the final output value with the following conditions: inverting input voltage (IN-) = V_{icm} and non-inverting input voltage (IN+) moving from V_{icm} - 100 mV to V_{icm} + overdrive.

⁽⁴⁾Response time is measured 10%/90% of the final output value with the following conditions: Inverting input voltage (IN-) = V_{icm} and non-inverting input voltage (IN+) moving from V_{icm} + 100 mV to V_{icm} - overdrive.

Table 4: Electrical characteristics at VCC = 3.3 V, Tamb = 25 ° C, and full Vicm range (unless otherwise specified)

Symbol	Parameter	Test conditions ⁽¹⁾	Min.	Typ.	Max.	Unit
V _{IO}	Input offset voltage	Tamb		0.2	6	mV
		-40 °C < Tamb < 150 °C		0.2	7	
$\Delta V_{IO}/\Delta T$	Input offset voltage drift	-40 °C < Tamb < 150 °C		3	20	$\mu V/^{\circ}C$
I _{IO}	Input offset current ⁽²⁾	Tamb		1	20	nA
		-40 °C < Tamb < 150 °C			100	
I _{IB}	Input bias current ⁽²⁾	Tamb		86	160	
		-40 °C < Tamb < 150 °C			300	
I _{CC}	Supply current	No load, output high, Vicm = 0 V		75	90	μA
		No load, output high, Vicm = 0 V, -40 °C < Tamb < 150 °C			120	
		No load, output low, Vicm = 0 V		86	110	
		No load, output low, Vicm = 0 V, -40 °C < Tamb < 150 °C			125	
I _{SC}	Short-circuit current	Source		26		mA
		Sink		24		
V _{OH}	Output voltage high	I _{source} = 1 mA	3.20	3.25		V
		-40 °C < Tamb < 150 °C	3.16			
V _{OL}	Output voltage low	I _{sink} = 1 mA		40	80	mV
		-40 °C < Tamb < 150 °C			120	
CMRR	Common-mode rejection ratio	0 < Vicm < 3.3 V		75		dB
SVR	Supply voltage rejection	$\Delta V_{CC} = 2$ to 5 V, Vicm = 0 V	58	73		
T _{PLH}	Propagation delay, low to high output level ⁽³⁾	Vicm = 0 V, f = 10 kHz, CL = 50 pF, overdrive = 100 mV		39	65	ns
		Vicm = 0 V, f = 10 kHz, CL = 50 pF, overdrive = 100 mV, -40 °C < Tamb < 150 °C			115	
		Vicm = 0 V, f = 10 kHz, CL = 50 pF, overdrive = 20 mV		50	85	
		Vicm = 0 V, f = 10 kHz, CL = 50 pF, overdrive = 20 mV, -40 °C < Tamb < 150 °C			145	

Symbol	Parameter	Test conditions ⁽¹⁾	Min.	Typ.	Max.	Unit
T _{PHL}	Propagation delay, high to low output level ⁽⁴⁾	V _{icm} = 0 V, f = 10 kHz, CL = 50 pF, overdrive = 100 mV		41	65	ns
		V _{icm} = 0 V, f = 10 kHz, CL = 50 pF, overdrive = 100 mV, -40 °C < T _{amb} < 150 °C			115	
		V _{icm} = 0 V, f = 10 kHz, CL = 50 pF, overdrive = 20 mV		51	80	
		V _{icm} = 0 V, f = 10 kHz, CL = 50 pF, overdrive = 20 mV, -40 °C < T _{amb} < 150 °C			145	
T _F	Fall time	f = 10 kHz, CL = 50 pF, RL = 10 kΩ, overdrive = 100 mV		5		
T _R	Rise time	f = 10 kHz, CL = 50 pF, RL = 10 kΩ, overdrive = 100 mV		7		

Notes:

⁽¹⁾All values over the temperature range are guaranteed through correlation and simulation. No production test is performed at the temperature range limits.

⁽²⁾Maximum values include unavoidable inaccuracies of the industrial tests

⁽³⁾Response time is measured 10%/90% of the final output value with the following conditions: inverting input voltage (IN-) = V_{icm} and non-inverting input voltage (IN+) moving from V_{icm} - 100 mV to V_{icm} + overdrive.

⁽⁴⁾Response time is measured 10%/90% of the final output value with the following conditions: Inverting input voltage (IN-) = V_{icm} and non-inverting input voltage (IN+) moving from V_{icm} + 100 mV to V_{icm} - overdrive.

Table 5: Electrical characteristics at VCC = 5 V, Tamb = 25 °C, and full Vicm range (unless otherwise specified)

Symbol	Parameter	Test conditions ⁽¹⁾	Min.	Typ.	Max.	Unit
V _{IO}	Input offset voltage	Tamb		0.2	6	mV
		-40 °C < Tamb < 150 °C		0.2	7	
$\Delta V_{IO}/\Delta T$	Input offset voltage drift	-40 °C < Tamb < 150 °C		3	20	$\mu V/^\circ C$
I _{IO}	Input offset current ⁽²⁾	Tamb		1	20	nA
		-40 °C < Tamb < 150 °C			100	
I _{IB}	Input bias current ⁽²⁾	Tamb		86	160	nA
		-40 °C < Tamb < 150 °C			300	
I _{CC}	Supply current	No load, output high, Vicm = 0 V		77	95	μA
		No load, output high, Vicm = 0 V, -40 °C < Tamb < 150 °C			125	
		No load, output low, Vicm = 0 V		89	115	
		No load, output low, Vicm = 0 V, -40 °C < Tamb < 150 °C			135	
I _{SC}	Short-circuit current	Source		51		mA
		Sink		40		
V _{OH}	Output voltage high	I _{source} = 4 mA	4.80	4.84		V
		-40 °C < Tamb < 150 °C	4.68			
V _{OL}	Output voltage low	I _{sink} = 4 mA		130	180	mV
		-40 °C < Tamb < 150 °C			270	
CMRR	Common-mode rejection ratio	0 < Vicm < 5 V		79		dB
SVR	Supply voltage rejection	$\Delta V_{CC} = 2$ to 5 V, Vicm = 0 V	58	73		
T _{PLH}	Propagation delay, low to high output level ⁽³⁾	Vicm = 0 V, f = 10 kHz, CL = 50 pF, overdrive = 100 mV		42	75	ns
		Vicm = 0 V, f = 10 kHz, CL = 50 pF, overdrive = 100 mV, -40 °C < Tamb < 150 °C			120	
		Vicm = 0 V, f = 10 kHz, CL = 50 pF, overdrive = 20 mV		54	105	
		Vicm = 0 V, f = 10 kHz, CL = 50 pF, overdrive = 20 mV, -40 °C < Tamb < 150 °C			150	

Symbol	Parameter	Test conditions ⁽¹⁾	Min.	Typ.	Max.	Unit
T _{PHL}	Propagation delay, high to low output level ⁽⁴⁾	V _{icm} = 0 V, f = 10 kHz, CL = 50 pF, overdrive = 100 mV		45	75	ns
		V _{icm} = 0 V, f = 10 kHz, CL = 50 pF, overdrive = 100 mV, -40 °C < T _{amb} < 150 °C			120	
		V _{icm} = 0 V, f = 10 kHz, CL = 50 pF, overdrive = 20 mV		55	95	
		V _{icm} = 0 V, f = 10 kHz, CL = 50 pF, overdrive = 20 mV, -40 °C < T _{amb} < 150 °C			150	
T _F	Fall time	f = 10 kHz, CL = 50 pF, RL = 10 kΩ, overdrive = 100 mV		4		
T _R	Rise time	f = 10 kHz, CL = 50 pF, RL = 10 kΩ, overdrive = 100 mV		4		

Notes:

⁽¹⁾All values over the temperature range are guaranteed through correlation and simulation. No production test is performed at the temperature range limits.

⁽²⁾Maximum values include unavoidable inaccuracies of the industrial tests

⁽³⁾Response time is measured 10%/90% of the final output value with the following conditions: inverting input voltage (IN-) = V_{icm} and non-inverting input voltage (IN+) moving from V_{icm} - 100 mV to V_{icm} + overdrive.

⁽⁴⁾Response time is measured 10%/90% of the final output value with the following conditions: Inverting input voltage (IN-) = V_{icm} and non-inverting input voltage (IN+) moving from V_{icm} + 100 mV to V_{icm} - overdrive.

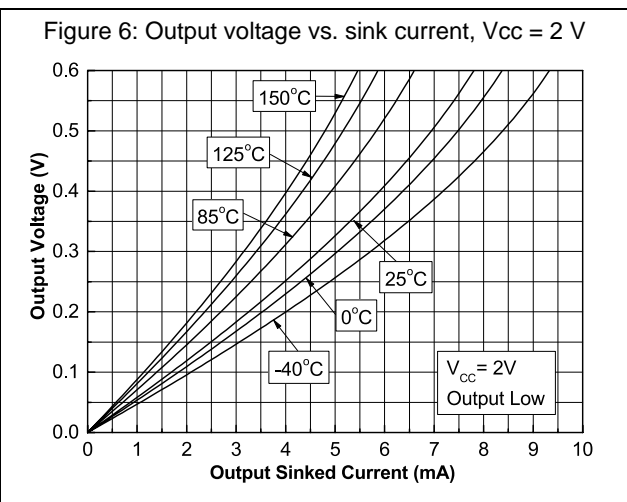
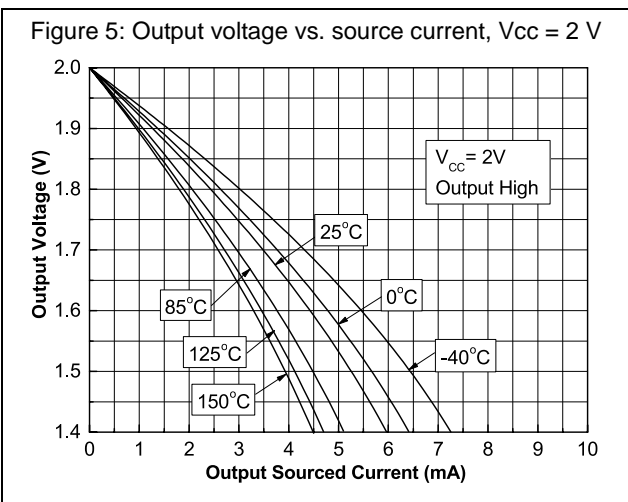
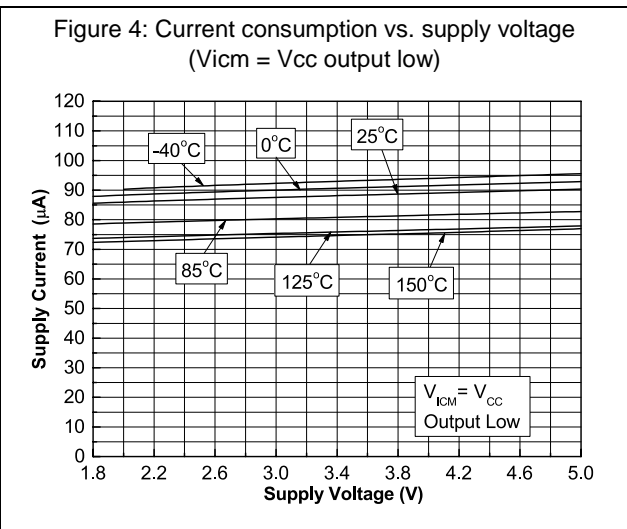
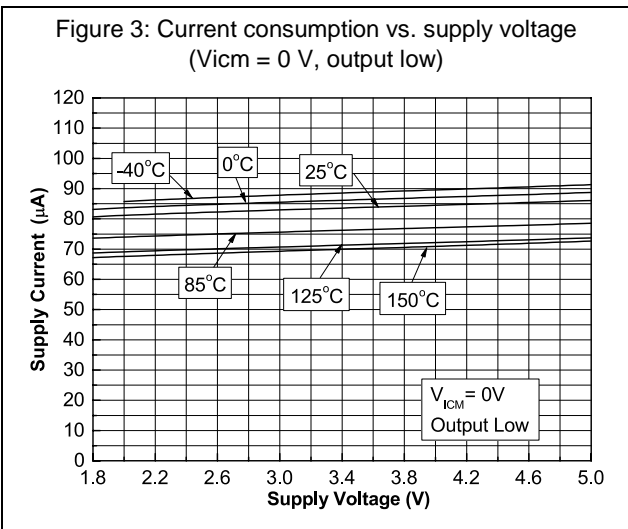
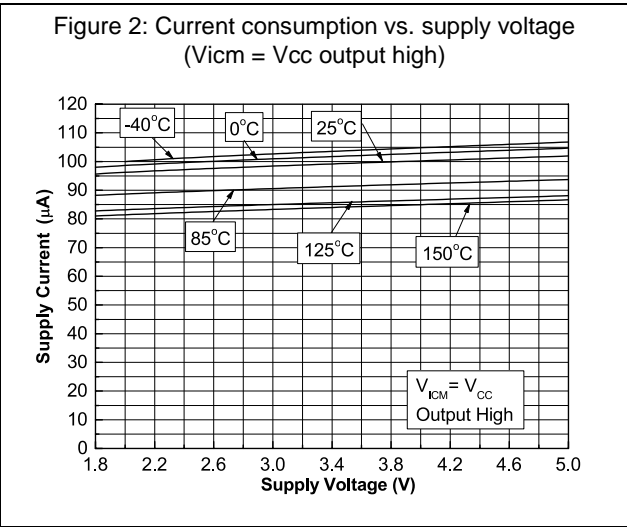
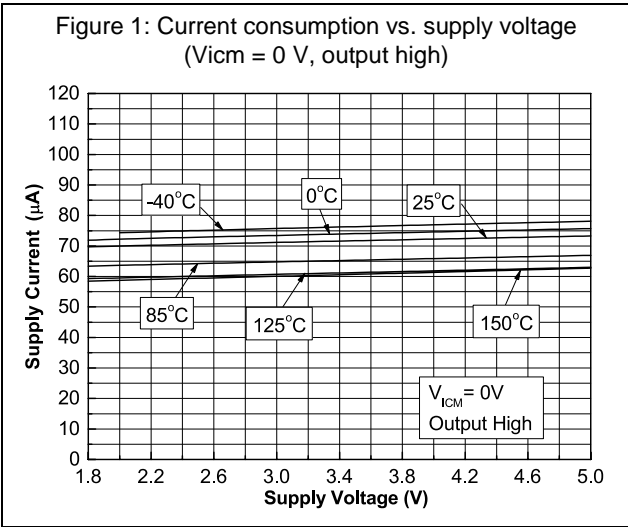

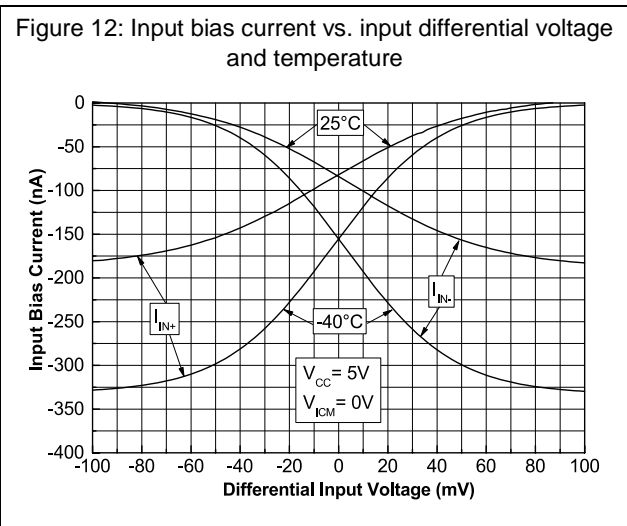
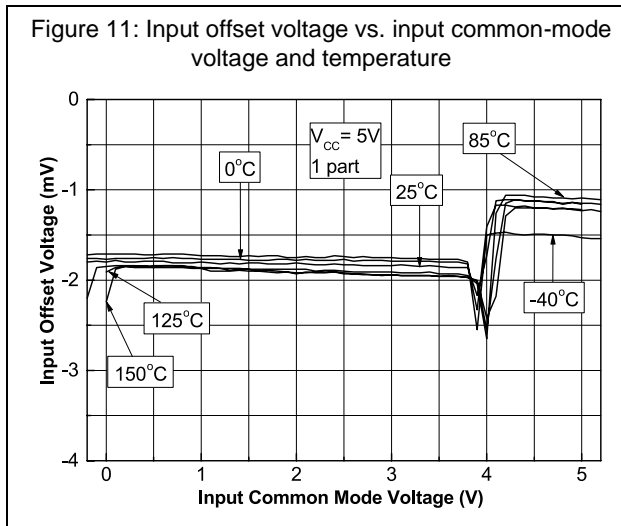
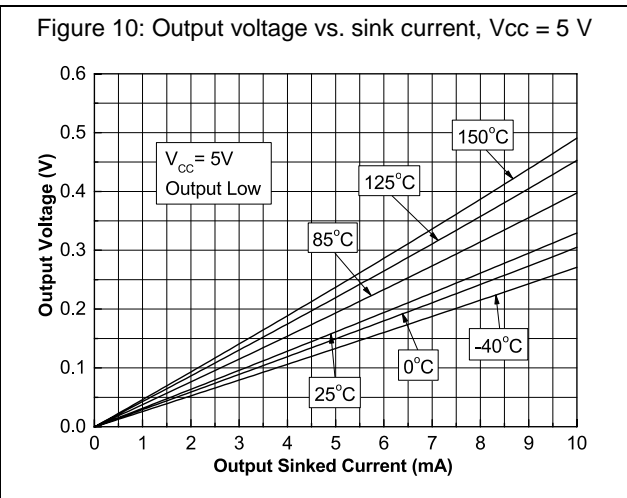
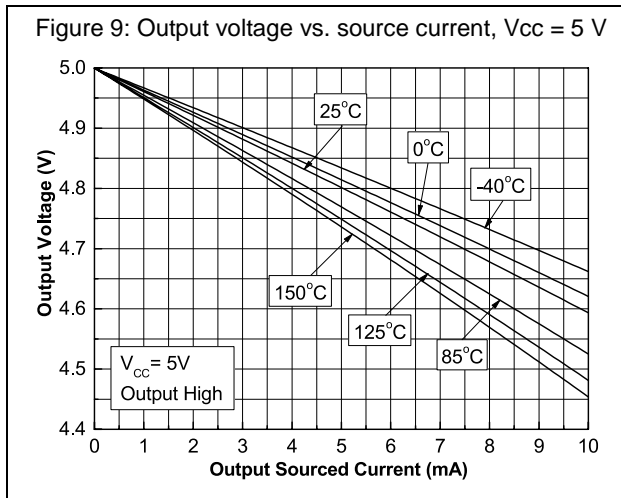
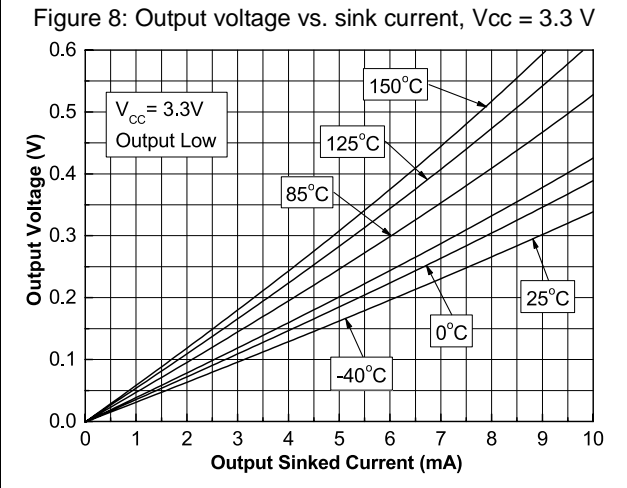
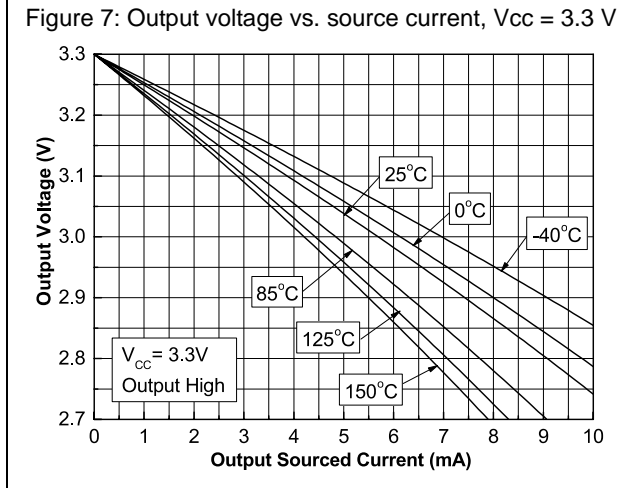

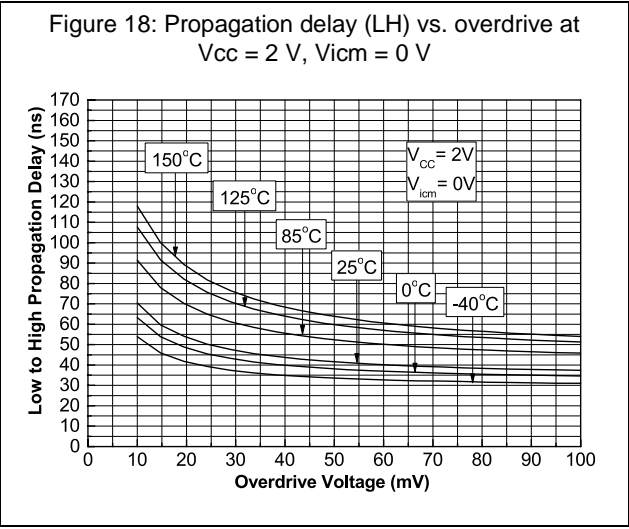
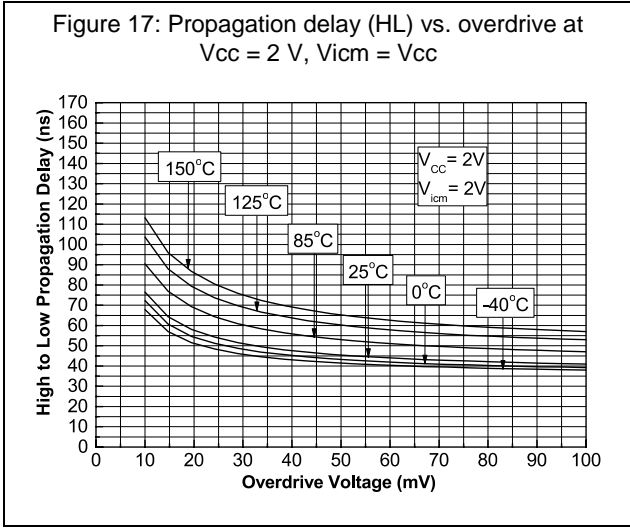
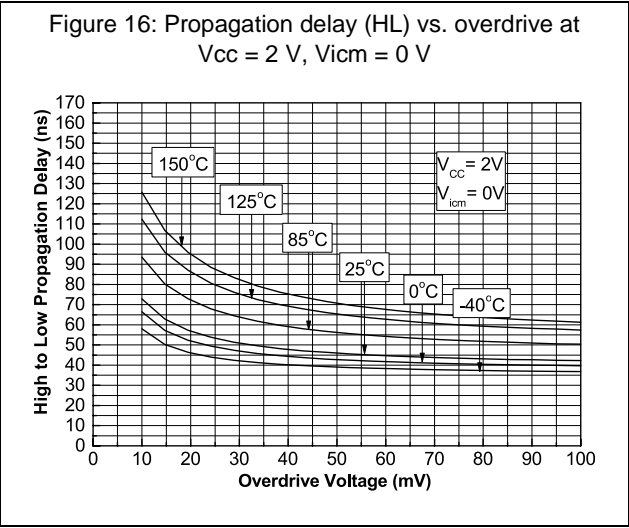
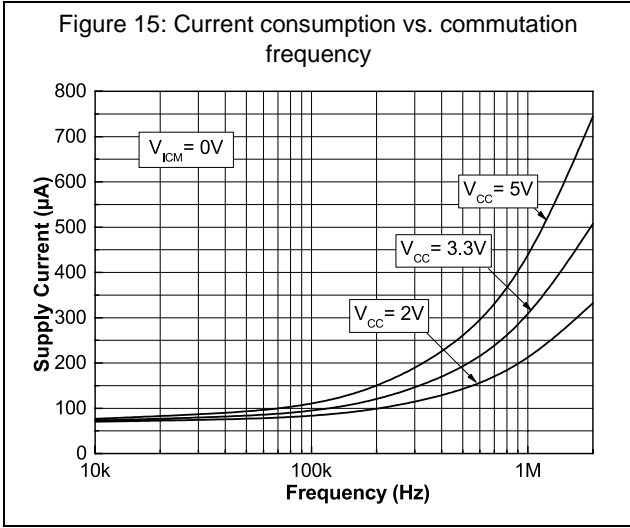
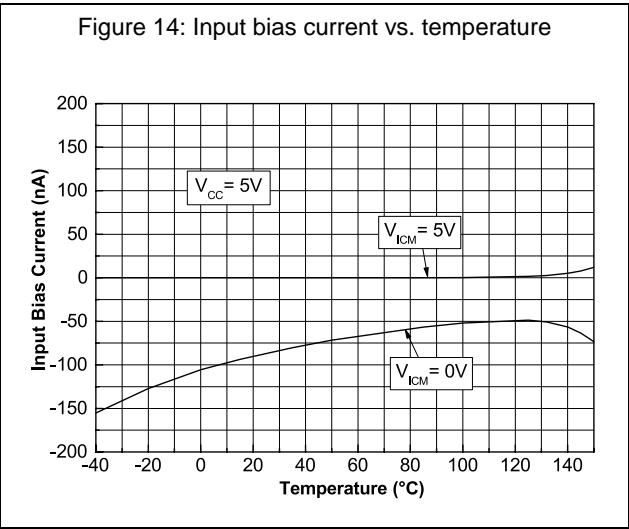
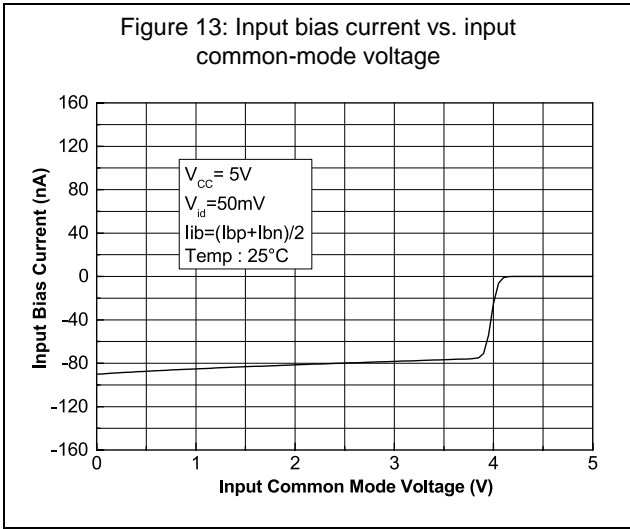

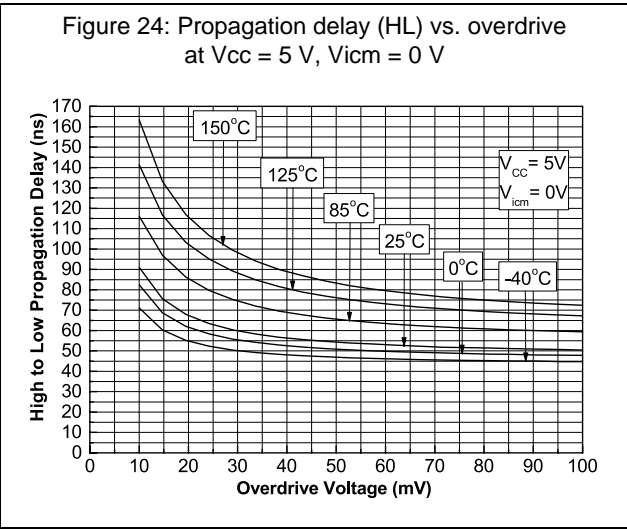
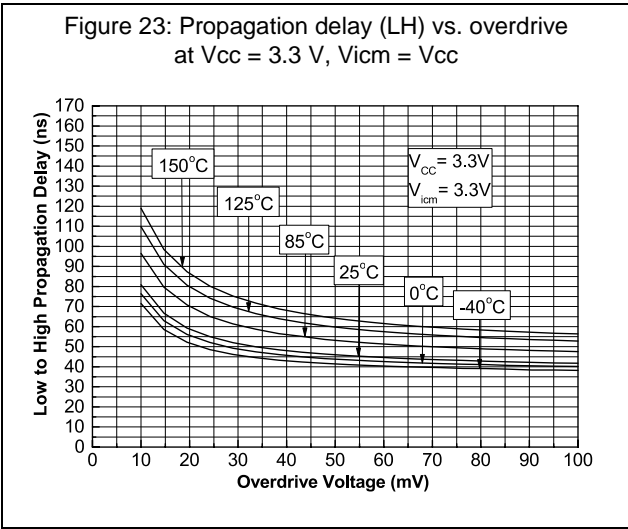
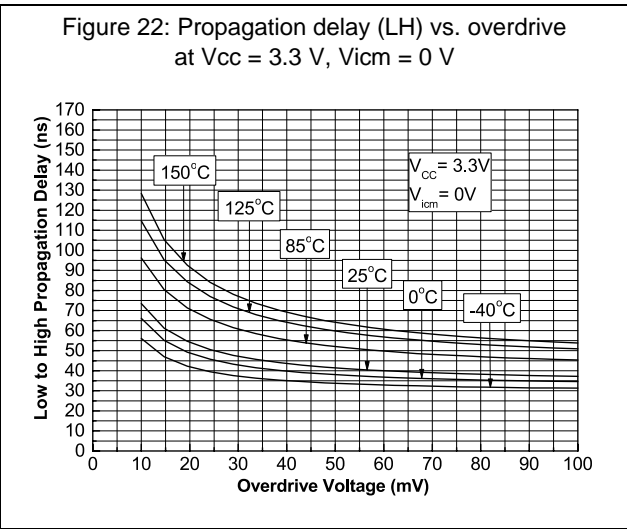
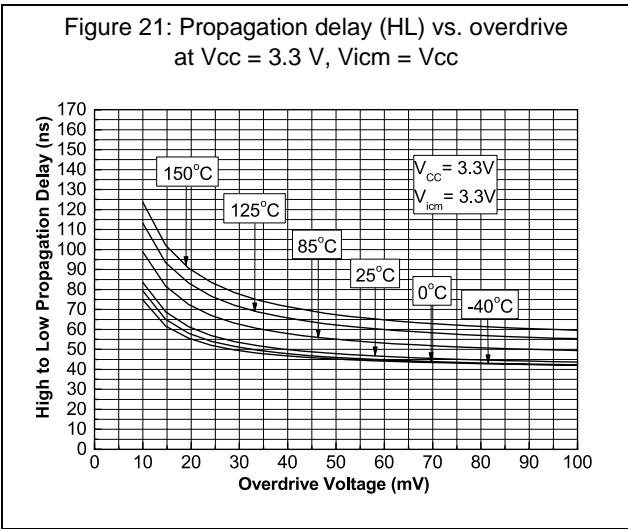
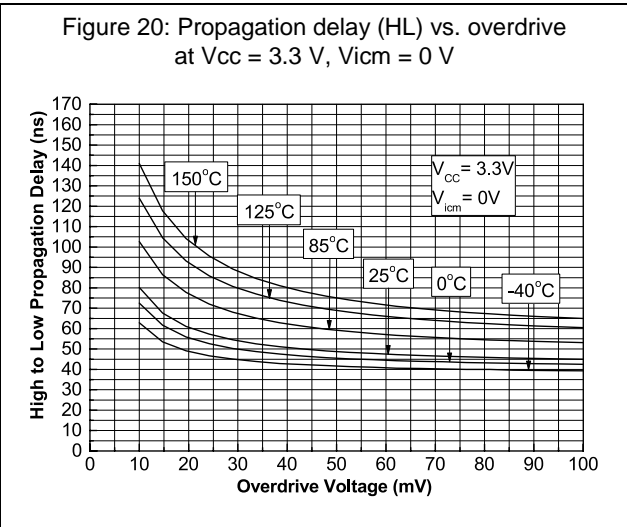
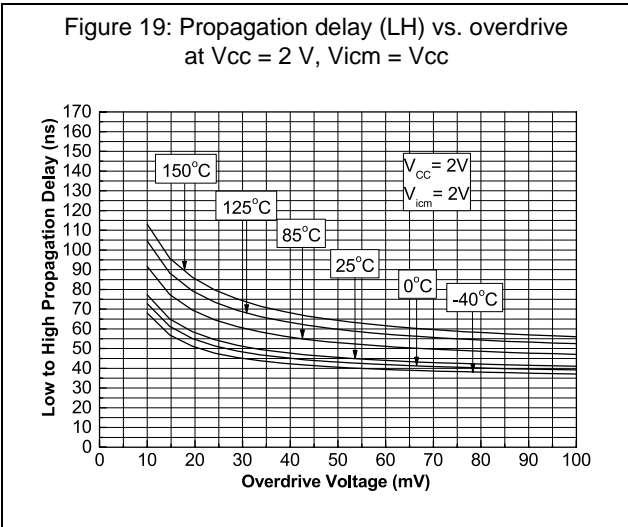

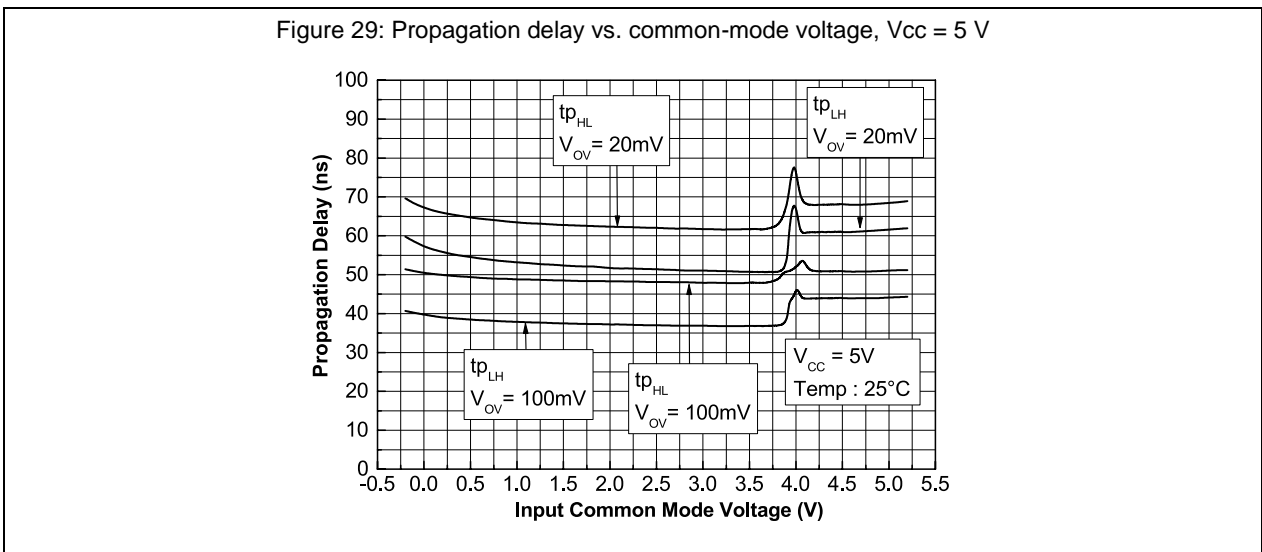
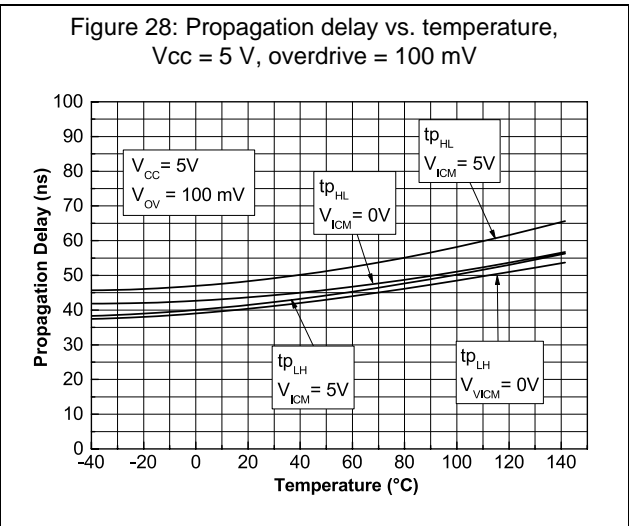
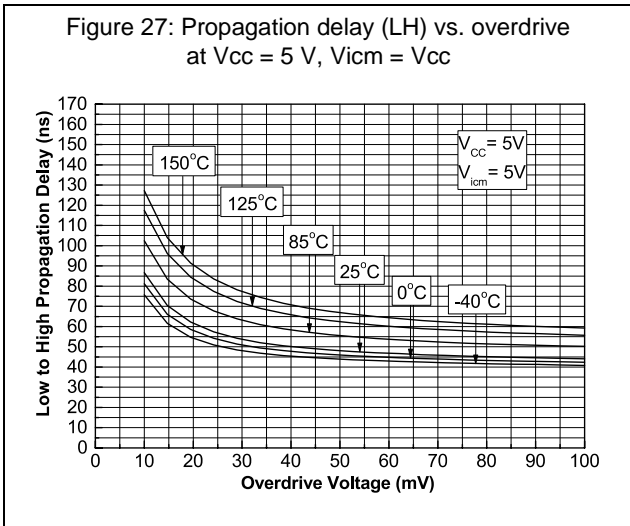
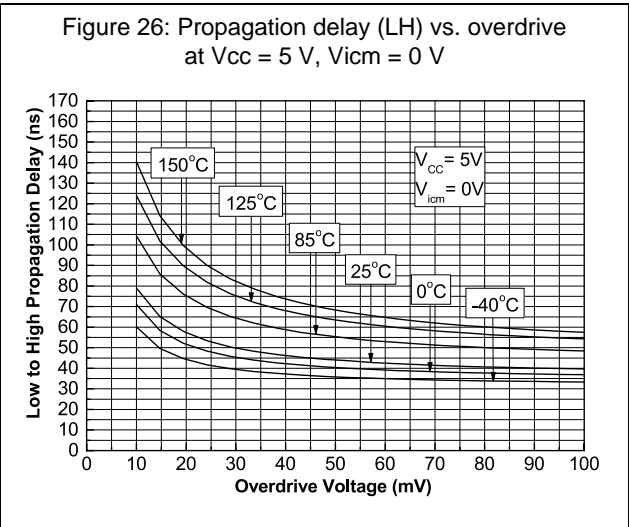
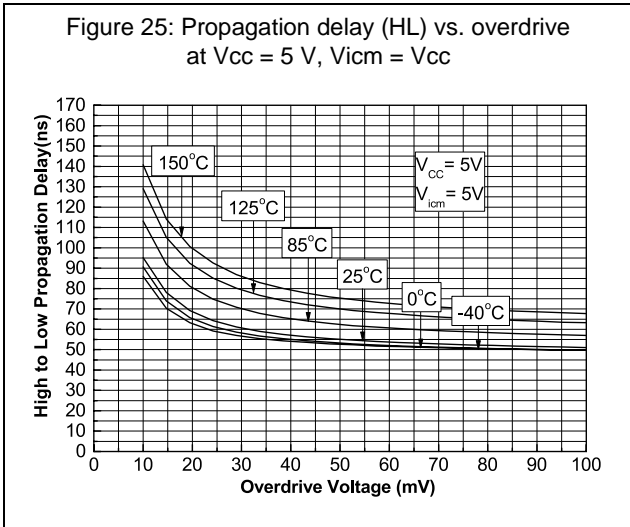

3 Package information

In order to meet environmental requirements, ST offers these devices in different grades of ECOPACK® packages, depending on their level of environmental compliance. ECOPACK® specifications, grade definitions and product status are available at: www.st.com. ECOPACK® is an ST trademark.

3.1 SOT23-5 package information

Figure 30: SOT23-5 package outline

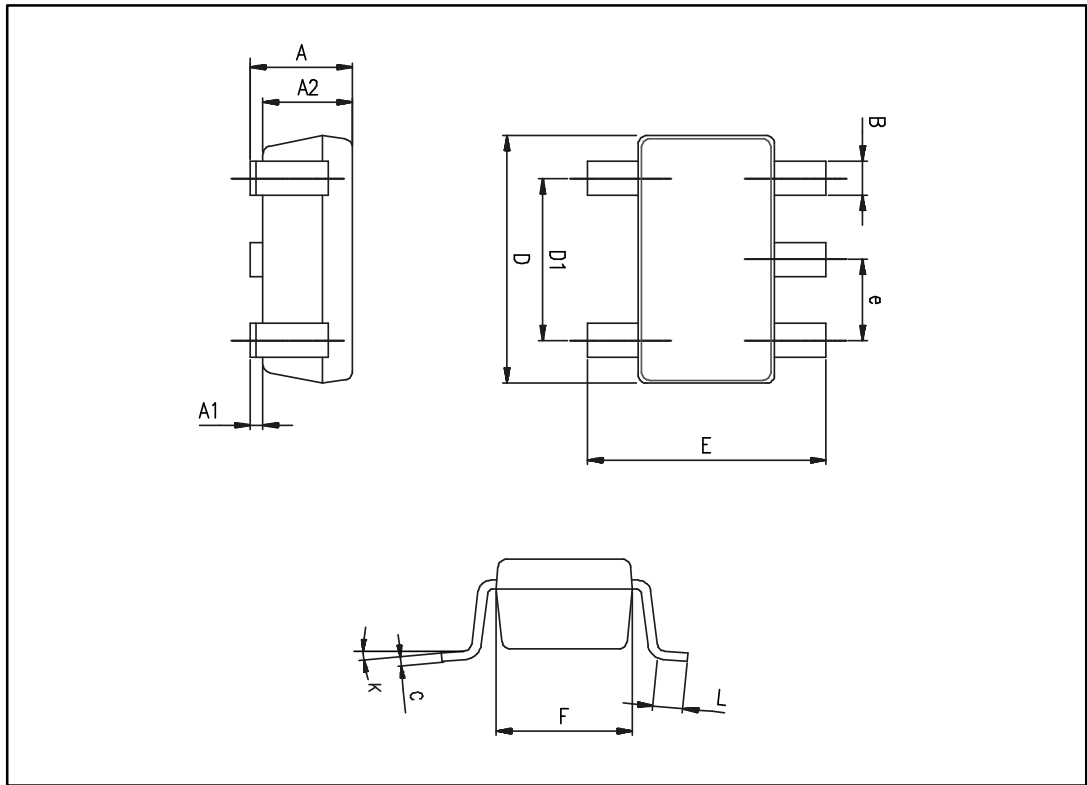

Table 6: SOT23-5 mechanical data

Ref.	Dimensions					
	Millimeters			Inches		
	Min.	Typ.	Max.	Min.	Typ.	Max.
A	0.90	1.20	1.45	0.035	0.047	0.057
A1			0.15			0.006
A2	0.90	1.05	1.30	0.035	0.041	0.051
B	0.35	0.40	0.50	0.014	0.016	0.020
C	0.09	0.15	0.20	0.004	0.006	0.008
D	2.80	2.90	3.00	0.110	0.114	0.118
D1		1.90			0.075	
e		0.95			0.037	
E	2.60	2.80	3.00	0.102	0.110	0.118
F	1.50	1.60	1.75	0.059	0.063	0.069
L	0.10	0.35	0.60	0.004	0.014	0.024
K	0 degrees		10 degrees	0 degrees		10 degrees

4 Ordering information

Table 7: Order codes

Order code	Temperature range	Package	Packaging	Marking
TS3021HIYLT ⁽¹⁾	-40 to 150 °C	SOT23-5	Tape and reel	K528

Notes:

⁽¹⁾Qualified and characterized according to AEC-Q100 and Q003 or equivalent, advanced screening according to AEC-Q001 and Q 002 or equivalent.

5 Revision history

Table 8: Document revision history

Date	Version	Changes
13-Oct-2015	1	Initial release
24-Aug-2016	2	Updated document title (automotive qualified) Added AEC-Q100 and Q003 qualified in Features section <i>Table 1: "Absolute maximum ratings (AMR)":</i> removed ESD MM value. <i>Table 7: "Order codes":</i> updated footnote, product is now automotive qualified.