

## Micropower quad CMOS voltage comparator

Datasheet - production data

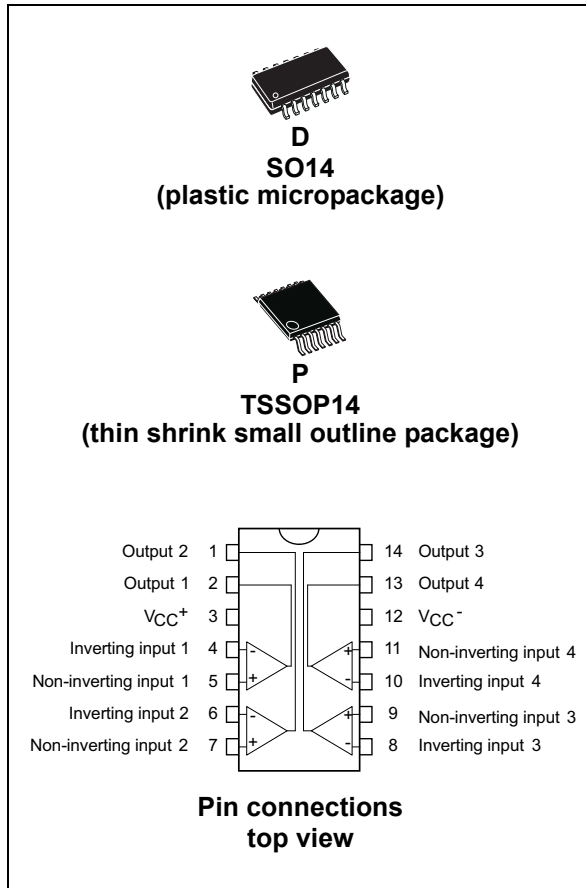

### Features

- Extremely low supply current: 9  $\mu$ A typ./comparator
- Wide single supply range 2.7 V to 16 V or dual supplies ( $\pm 1.35$  V to  $\pm 8$  V)
- Extremely low input bias current: 1 pA typ.
- Extremely low input offset current: 1 pA typ.
- Input common-mode voltage range includes GND
- High input impedance:  $10^{12}$   $\Omega$  typ.
- Fast response time: 1.5  $\mu$ s typ. for 5 mV overdrive
- Pin-to-pin and functionally compatible with bipolar LM339 device

### Description

The TS339 device is a micro-power, CMOS, quad voltage comparator with extremely low consumption of 9  $\mu$ A typ./comparator (20 times less than the bipolar LM339). Similar performances are offered by the quad micro-power comparator TS3704 with a push-pull CMOS output. Thus response times remain similar to the LM339 device.

**Table 1. Device summary**

Order code	Temperature range	Package	Packaging	Marking
TS339CD/CDT	0 °C, 70 °C	SO14	Tube or tape and reel	S339C
TS339IDT	-40 °C, 125 °C			TSSOP14
TS339IPT				

# Contents

<b>1</b>	<b>Absolute maximum ratings</b> .....	<b>3</b>
<b>2</b>	<b>Typical application schematics</b> .....	<b>4</b>
<b>3</b>	<b>Electrical characteristics</b> .....	<b>5</b>
<b>4</b>	<b>Package information</b> .....	<b>7</b>
	4.1 SO14 package .....	8
	4.2 TSSOP14 package .....	9
<b>5</b>	<b>Revision history</b> .....	<b>10</b>

# 1 Absolute maximum ratings

**Table 2. Key parameters and their absolute maximum ratings**

Symbol	Parameter	Value	Unit
$V_{CC}^+$	Supply voltage <sup>(1)</sup>	18	V
$V_{id}$	Differential input voltage <sup>(2)</sup>	±18	
$V_i$	Input voltage <sup>(3)</sup>	18	
$V_o$	Output voltage	18	
$I_o$	Output current	20	mA
$I_F$	Forward current in ESD protection diodes on inputs <sup>(4)</sup>	50	
$P_d$	Power dissipation <sup>(5)</sup>		mW
	SO14 TSSOP14	830 710	
$T_{stg}$	Storage temperature range	-65 to +150	°C
ESD	HBM: human body model <sup>(6)</sup>	50	V
	MM: machine model <sup>(7)</sup>	40	
	CDM: charged device model	800	

- All voltage values, except the differential voltage, are with respect to network ground terminal.
- Differential voltages are the non-inverting input terminal with respect to the inverting input terminal.
- Excursions of input voltages may exceed the power supply level. As long as the common mode voltage [ $V_{icm}=(V_{in}^+ + V_{in}^-)/2$ ] remains within the specified range, the comparator will provide a stable output state. However, the maximum current through the ESD diodes ( $I_F$ ) of the input stage must strictly be observed.
- Guaranteed by design.
- $P_d$  is calculated with  $T_{amb} = +25\text{ °C}$ ,  $T_j = +150\text{ °C}$  and  
 $R_{thja} = 150\text{ °C/W}$  for SO14 package  
 $R_{thja} = 175\text{ °C/W}$  for TSSOP14 package.
- Human body model, 100pF discharged through a 1.5 kΩ resistor into pin of device.
- Machine model ESD, a 200 pF cap is charged to the specified voltage, then discharged directly into the IC with no external series resistor (internal resistor < 5 Ω), into pin to pin of device.

## 2 Typical application schematics

Figure 1. Schematic diagram (for 1/4 TS339)

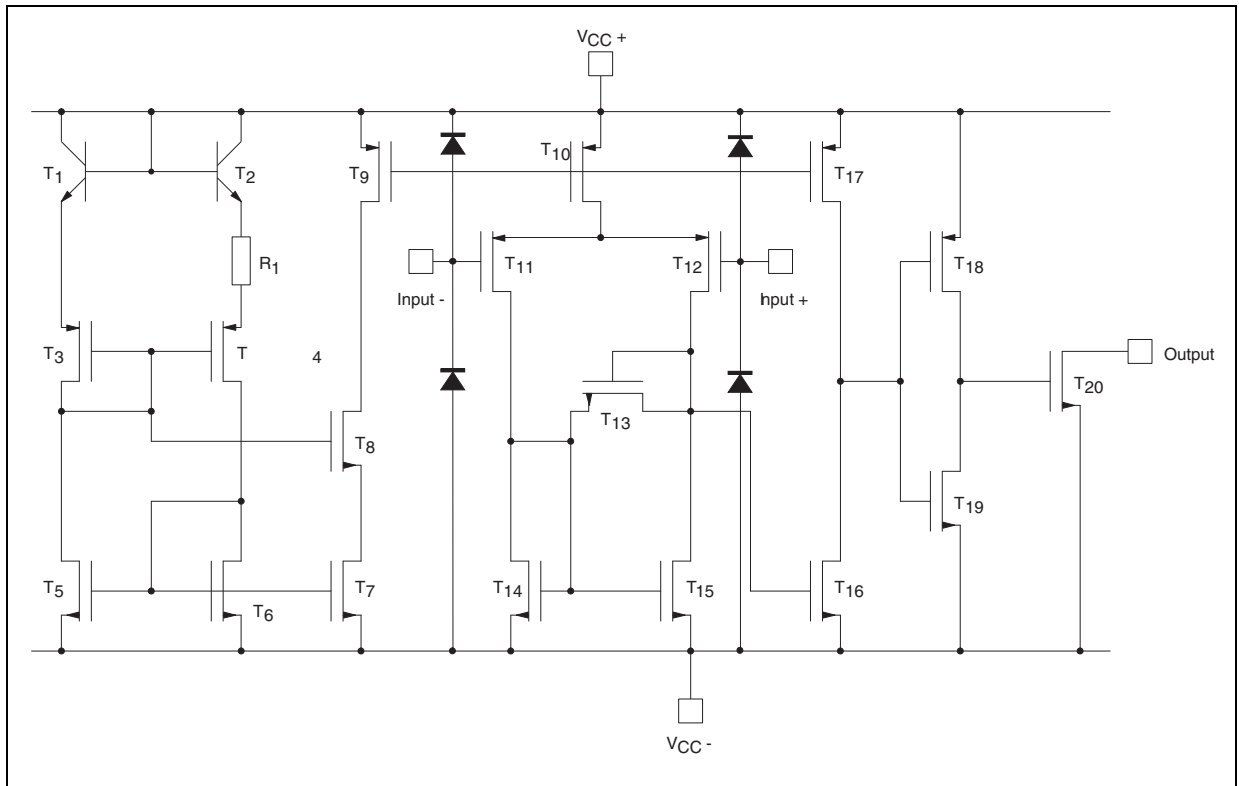

### 3 Electrical characteristics

Table 3.  $V_{CC}^+ = 3\text{ V}$ ,  $V_{CC}^- = 0\text{ V}$ ,  $T_{amb} = 25\text{ °C}$  (unless otherwise specified)

Symbol	Parameter	Min.	Typ.	Max.	Unit
$V_{io}$	Input offset voltage <sup>(1)</sup> $V_{ic} = 1.5\text{ V}$ $T_{min.} \leq T_{amb} \leq T_{max.}$			5 6.5	mV
$I_{io}$	Input offset current <sup>(2)</sup> $V_{ic} = 1.5\text{ V}$ $T_{min.} \leq T_{amb} \leq T_{max.}$		1	300	pA
$I_{ib}$	Input bias current <sup>(2)</sup> $V_{ic} = 1.5\text{ V}$ $T_{min.} \leq T_{amb} \leq T_{max.}$		1	600	
$V_{icm}$	Input common mode voltage range $T_{min.} \leq T_{amb} \leq T_{max.}$	0 0		$V_{CC}^+ - 1.2$ $V_{CC}^+ - 1.5$	V
CMR	Common-mode rejection ratio $V_{ic} = V_{icm\ min.}$		70		dB
SVR	Supply voltage rejection ratio $V_{CC}^+ = 3\text{ V to }5\text{ V}$		70		
$I_{OH}$	High level output current $V_{id} = +1\text{ V}$ , $V_{OH} = 3\text{ V}$ $T_{min.} \leq T_{amb} \leq T_{max.}$		2	40 1000	nA
$V_{OL}$	Low level output voltage $V_{id} = -1\text{ V}$ , $I_{OL} = +6\text{ mA}$ $T_{min.} \leq T_{amb} \leq T_{max.}$		400	550 800	mV
$I_{CC}$	Supply current (each comparator) No load - outputs low $T_{min.} \leq T_{amb} \leq T_{max.}$		9	20 25	$\mu\text{A}$
$t_{PLH}$	Response time low to high $V_{ic} = 0\text{ V}$ , $f = 10\text{ kHz}$ , $T_{min.} \leq T_{amb} \leq T_{max.}$ , $C_L = 50\text{ pF}$ , overdrive = 5 mV TTL input		1.5 0.7		$\mu\text{s}$
$t_{PHL}$	Response time high to low $V_{ic} = 0\text{ V}$ , $f = 10\text{ kHz}$ , $R_L = 5.1\text{ k}\Omega$ , $C_L = 50\text{ pF}$ , overdrive = 5 mV TTL input		2.5 0.08		

1. The specified offset voltage is the maximum value required to drive the output up to 2.5 V or down to 0.3 V.

2. Maximum values including unavoidable inaccuracies of the industrial test.

Table 4.  $V_{CC}^+ = 5\text{ V}$ ,  $V_{CC}^- = 0\text{ V}$ ,  $T_{amb} = 25\text{ }^\circ\text{C}$  (unless otherwise specified)

Symbol	Parameter	Min.	Typ.	Max.	Unit
$V_{io}$	Input offset voltage <sup>(1)</sup> $V_{ic} = 2.5\text{ V}$ , $V_{CC}^+ = 5\text{ V to } 10\text{ V}$ $T_{min.} \leq T_{amb} \leq T_{max.}$		1.4	5 6.5	mV
$I_{io}$	Input offset current <sup>(2)</sup> $V_{ic} = 2.5\text{ V}$ $T_{min.} \leq T_{amb} \leq T_{max.}$		1	300	pA
$I_{ib}$	Input bias current <sup>(2)</sup> $V_{ic} = 2.5\text{ V}$ $T_{min.} \leq T_{amb} \leq T_{max.}$		1	600	
$V_{icm}$	Input common mode voltage range $T_{min.} \leq T_{amb} \leq T_{max.}$	0 0		$V_{CC}^+ - 1.2$ $V_{CC}^+ - 1.5$	V
CMR	Common-mode rejection ratio $V_{ic} = 0\text{ V}$		75		dB
SVR	Supply voltage rejection ratio $V_{CC}^+ = +5\text{ V to } +10\text{ V}$		85		
$I_{OH}$	High level output voltage $V_{id} = 1\text{ V}$ , $V_{OH} = +5\text{ V}$ $T_{min.} \leq T_{amb} \leq T_{max.}$		27	40 1000	nA
$V_{OL}$	Low level output voltage $V_{id} = -1\text{ V}$ , $I_{OL} = 6\text{ mA}$ $T_{min.} \leq T_{amb} \leq T_{max.}$		260	400 650	mV
$I_{CC}$	Supply current (each comparator) No load - outputs low $T_{min.} \leq T_{amb} \leq T_{max.}$		10	20 25	$\mu\text{A}$
$t_{PLH}$	Response time low to high $V_{ic} = 0\text{ V}$ , $f = 10\text{ kHz}$ , $R_L = 5.1\text{ k}\Omega$ , $C_L = 15\text{ pF}$ , overdrive = 5 mV Overdrive = 10 mV Overdrive = 20 mV Overdrive = 40 mV TTL input		1.5 1.2 1.1 0.9 0.8		$\mu\text{s}$
$t_{PHL}$	Response time high to low $V_{ic} = 0\text{ V}$ , $f = 10\text{ kHz}$ , $R_L = 5.1\text{ k}\Omega$ , $C_L = 15\text{ pF}$ , overdrive = 5 mV Overdrive = 10 mV Overdrive = 20 mV Overdrive = 40 mV TTL input		2.5 1.9 1.2 0.8 0.08		
$t_f$	Fall time $f = 10\text{ kHz}$ , $C_L = 50\text{ pF}$ , $R_L = 5.1\text{ k}\Omega$ , overdrive 50 mV		30		ns

1. The specified offset voltage is the maximum value required to drive the output up to 4.5 V or down to 0.3 V.
2. Maximum values including unavoidable inaccuracies of the industrial test.

## 4 Package information

In order to meet environmental requirements, ST offers these devices in different grades of ECOPACK® packages, depending on their level of environmental compliance. ECOPACK specifications, grade definitions and product status are available at: [www.st.com](http://www.st.com). ECOPACK is an ST trademark.

### 4.1 SO14 package information

Figure 2. SO14 package outline

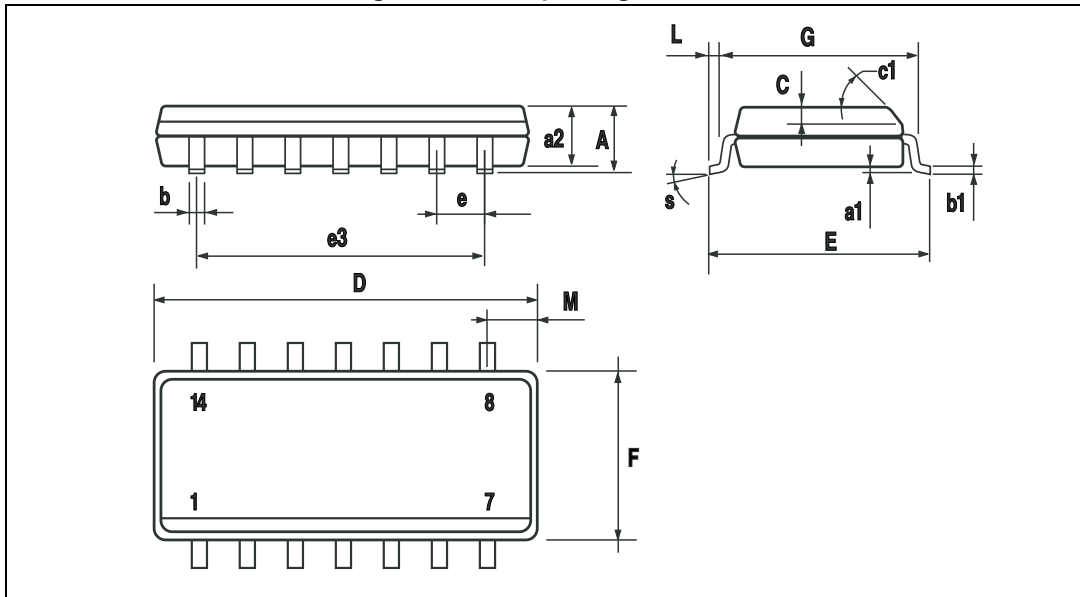

Table 5. SO14 package mechanical data

Symbol	Dimensions					
	mm			inch		
	Min.	Typ.	Max.	Min.	Typ.	Max.
A			1.75			0.068
a1	0.1		0.2	0.003		0.007
a2			1.65			0.064
b	0.35		0.46	0.013		0.018
b1	0.19		0.25	0.007		0.010
C		0.5			0.019	
c1	45° (typ.)					
D	8.55		8.75	0.336		0.344
E	5.8		6.2	0.228		0.244
e		1.27			0.050	
e3		7.62			0.300	
F	3.8		4.0	0.149		0.157
G	4.6		5.3	0.181		0.208
L	0.5		1.27	0.019		0.050
M			0.68			0.026
S	8° (max.)					



## 4.2 TSSOP14 package information

Figure 3. TSSOP14 package outline

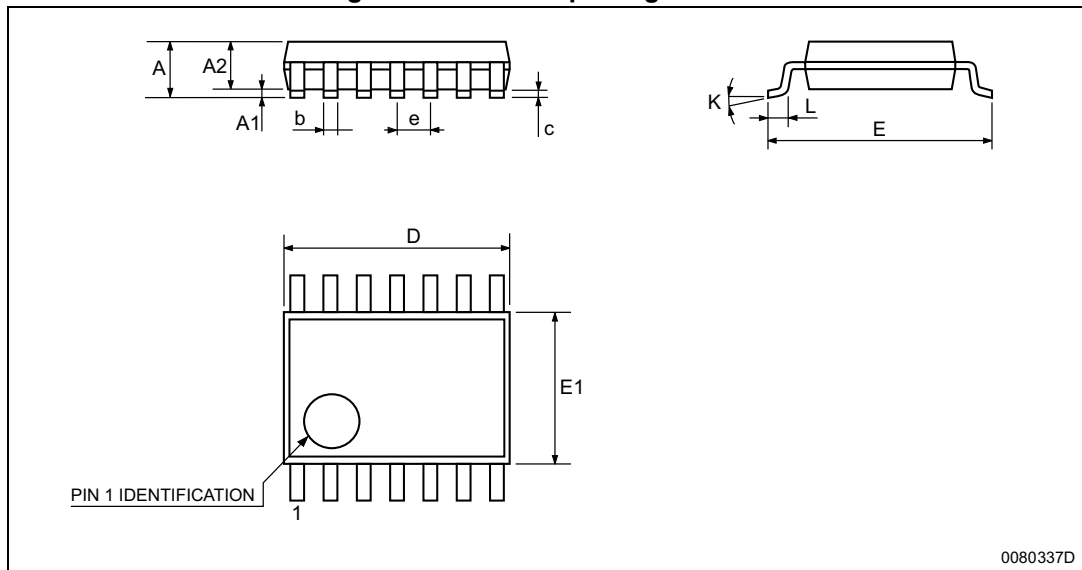

Table 6. TSSOP14 package mechanical data

Symbol	Dimensions					
	mm.			inch		
	Min.	Typ.	Max.	Min.	Typ.	Max.
A			1.2			0.047
A1	0.05		0.15	0.002	0.004	0.006
A2	0.8	1	1.05	0.031	0.039	0.041
b	0.19		0.30	0.007		0.012
c	0.09		0.20	0.004		0.0089
D	4.9	5	5.1	0.193	0.197	0.201
E	6.2	6.4	6.6	0.244	0.252	0.260
E1	4.3	4.4	4.48	0.169	0.173	0.176
e		0.65 BSC			0.0256 BSC	
K	0°		8°	0°		8°
L	0.45	0.60	0.75	0.018	0.024	0.030

## 5 Revision history

Table 7. Document revision history

Date	Revision	Changes
Jan. 2003	1	Initial release.
Aug. 2005	2	1 - PPAP references inserted in the datasheet see <a href="#">Table 1: Order codes on page 1</a> . 2 - ESD protection inserted in <a href="#">Table 2 Key parameters and their absolute maximum ratings on page 2</a> .
04-Sep-2012	3	Updated <a href="#">Features, Table 1</a> , removed TS339IYD and TS339IYDT from <a href="#">Table 1</a> . Updated ECOPACK text, reformatted <a href="#">Section 4: Package information</a> . Minor corrections throughout document.
21-Feb-2014	4	Removed DIP package <a href="#">Features</a> : updated fast response time <a href="#">Device summary</a> : removed order codes TS339CN, TS339IN, and TS339ID; added temperature range for order codes TS339IDT and TS339IPT