

Precision micropower shunt voltage reference

Datasheet - production data

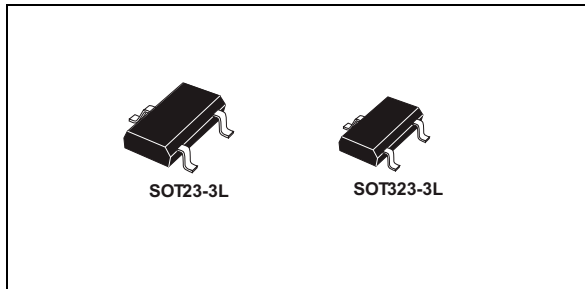

Description

The TS4061 is a low power and high accuracy shunt voltage reference providing a stable output voltage over the industrial temperature range (-40 to +85 °C), with a maximum temperature coefficient of 35 ppm/°C. It is available in 0.1% and 0.2% initial accuracy versions. The SOT323-3L and SOT23-3L packages can be designed in applications where space saving is a critical issue. The very low operating current is a key advantage for power restricted designs. The TS4061 is very stable and can be used in a broad range of application conditions.

Features

- Fixed 1.225 V, 1.25 V output voltages
- Ultra low operating current: 10 μ A at 25 °C
- High precision @ 25 °C: +/-0.1% (TS4061A), +/- 0.2% (TS4061B)
- Very low LF noise: typ. 10 μ V_{p-p}
- Stable when used with capacitive loads
- Industrial (-40 to +85 °C) temperature range
- 35 ppm/°C max. temperature coefficient
- Available in SOT23-3L and SOT323-3L packages

Applications

- Portable, battery-operated equipment
- Data acquisition systems
- Instrumentation

Contents

1	Pin configuration	3
2	Maximum ratings	4
3	Electrical characteristics	5
4	Typical performance characteristics	6
5	Package mechanical data	8
5.1	SOT23-3L, TS4061	8
5.2	SOT323-3L, TS4061	10
6	Ordering information	12
7	Revision history	13

1 Pin configuration

Figure 1. Pin configuration SOT23-3L, SOT323-3L (top view)

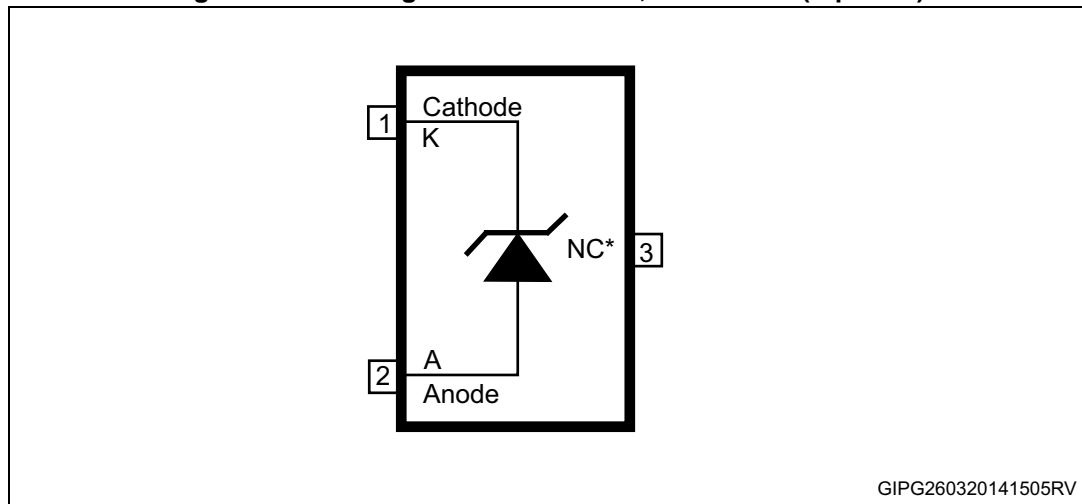

Note: The NC pin must be left unconnected or connected to anode.

2 Maximum ratings

Table 1. Absolute maximum ratings

Symbol	Parameter	Value	Unit
I_k	Reverse breakdown current	20	mA
I_f	Forward current	15	mA
P_d	Power dissipation ⁽¹⁾	500	mW
T_{std}	Storage temperature	-65 to +150	°C
E_{SD}	Human body model (HBM)	2	kV
	Machine model (MM)	200	V
	Charged device model	1500	V
T_{lead}	Lead temperature (soldering) 10 sec	260	°C
T_j	Max. junction temperature	+150	°C

1. P_d has been calculated with $T_{amb} = 25\text{ °C}$ and $T_{jmax} = 150\text{ °C}$

Note: Absolute maximum ratings are those values beyond which damage to the device may occur. Functional operation under these conditions is not implied.

Table 2. Thermal data

Symbol	Parameter	SOT323-3L	SOT23-3L	Unit
R_{thJA}	Thermal resistance junction-ambient	246	242	°C/W
R_{thJC}	Thermal resistance junction-case	171	103	°C/W

Table 3. Operating conditions

Symbol	Parameter	Value	Unit
I_{kmin}	Minimum operating current	10	μA
I_{kmax}	Maximum operating current	15	mA
T_{oper}	Operating free air temperature range	-40 to +85	°C

3 Electrical characteristics

Limits are 100% production tested at 25 °C. Limits over full temperature range are guaranteed through correlation and by design. $I_k = 10 \mu\text{A}$, $T_{\text{amb}} = 25 \text{ °C}$ (unless otherwise specified).

Table 4. Electrical characteristics for TS4061

Symbol	Parameter	Test conditions	Min.	Typ.	Max.	Unit
V_k	Reverse breakdown voltage ($V_k = 1.225 \text{ V}$)	$I_k = 10 \mu\text{A}$, TS4061A	1.2237	1.225	1.2262	V
		$I_k = 10 \mu\text{A}$, TS4061B	1.2225		1.2275	
	Reverse breakdown voltage ($V_k = 1.25 \text{ V}$)	$I_k = 10 \mu\text{A}$, TS4061A	1.2487	1.25	1.2512	V
		$I_k = 10 \mu\text{A}$, TS4061B	1.2475		1.2525	
$I_{k\text{min}}$	Minimum operating current	$T_{\text{amb}} = 25 \text{ °C}$		7.5	10	μA
		$-40 \text{ °C} < T_{\text{amb}} < +85 \text{ °C}$			12	
$\Delta V_k / \Delta T$	Average temperature coefficient	$10 \mu\text{A} < I_k < 15 \text{ mA}$		20	35	ppm/ $^{\circ}\text{C}$
$\Delta V_k / \Delta I_k$	Reverse breakdown voltage change with operating current range	$I_{k\text{min}} < I_k < 1 \text{ mA}$ $-40 \text{ °C} < T_{\text{amb}} < +85 \text{ °C}$		0.2	1	mV
		$1 \text{ mA} < I_k < 15 \text{ mA}$ $-40 \text{ °C} < T_{\text{amb}} < +85 \text{ °C}$		1.7	4	
R_{ka}	Static impedance	$\Delta I_k = 10 \mu\text{A}$ to 10 mA		0.15	0.3	Ω
Hys	Thermal hysteresis ⁽¹⁾	$I_k = 10 \mu\text{A}$		120		ppm
Noise	Wideband noise	$I_k = 10 \mu\text{A}$ $10 \text{ Hz} < f < 10 \text{ kHz}$		95		μVRMS
	Low frequency noise	$I_k = 10 \mu\text{A}$ $0.1 \text{ Hz} < f < 10 \text{ Hz}$		10		$\mu\text{Vp-p}$

1. Thermal hysteresis is defined as the difference in voltage measured at +25 °C after cycling to -40 °C and the measurement at +25 °C after cycling to temperature +85 °C.

4 Typical performance characteristics

(The following plots are referred to the typical application circuit and, unless otherwise noted, at $T_A = 25\text{ }^\circ\text{C}$)

Figure 2. V_K change vs temperature (1.225 V version)

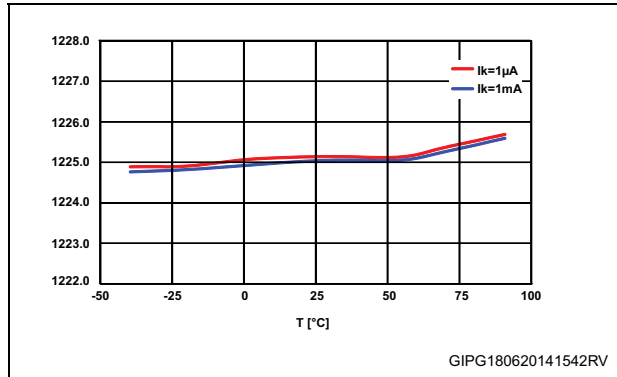

Figure 3. V_K change vs temperature (1.25 V version)

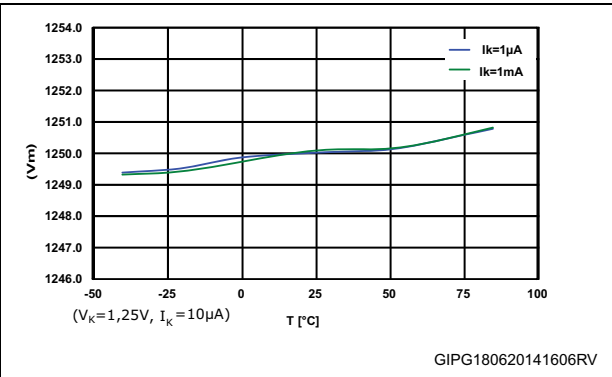

Figure 4. I_{Kmin} minimum current for regulation

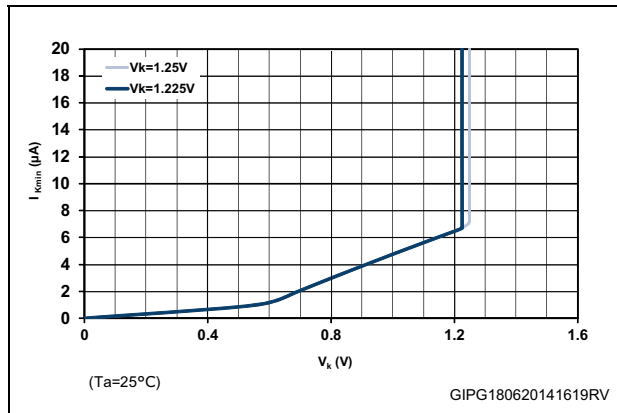

Figure 5. I_{Kmin} minimum current for regulation vs temperature

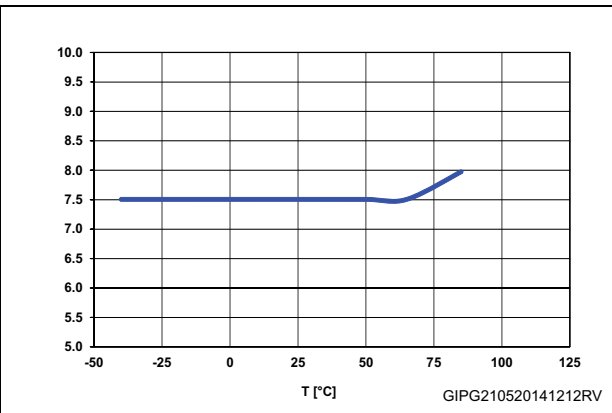

Figure 6. Output impedance vs frequency

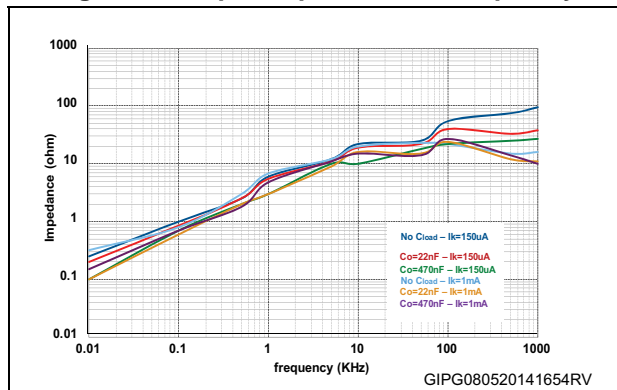

Figure 7. Forward characteristics

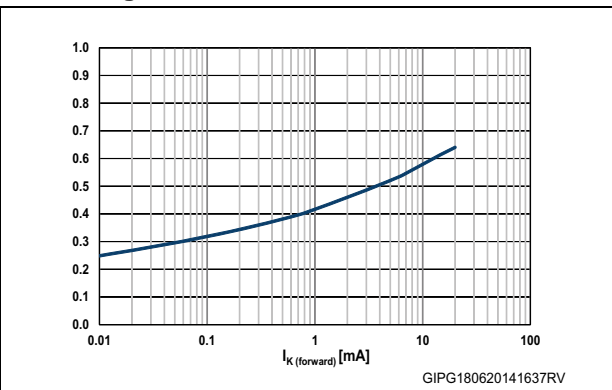

Figure 8. Start-up waveform (no C_{load})

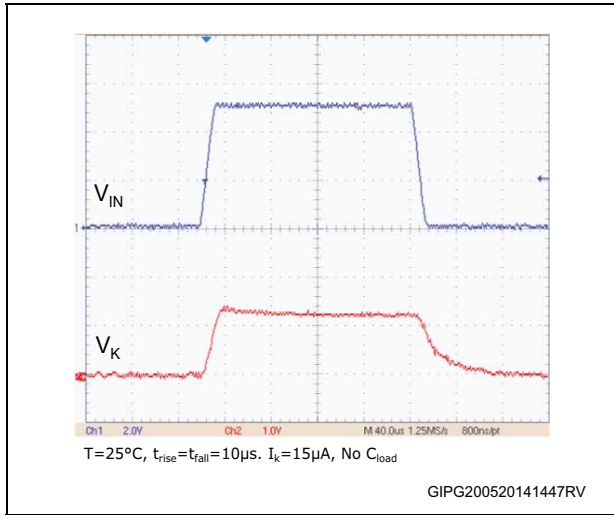

Figure 9. Start-up waveform ($C_{load} = 100\text{ nF}$)

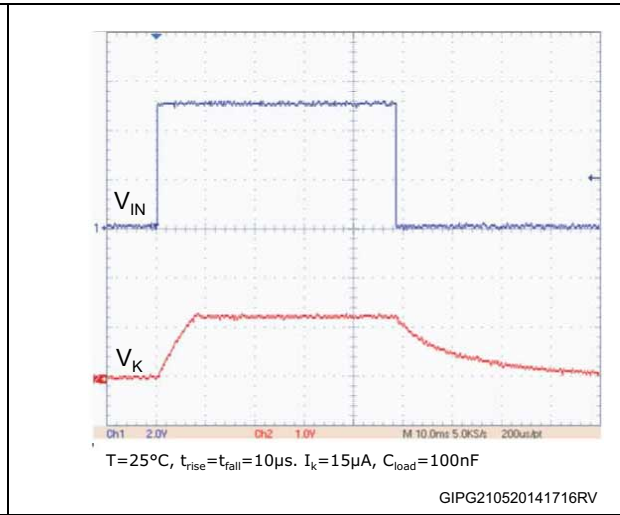
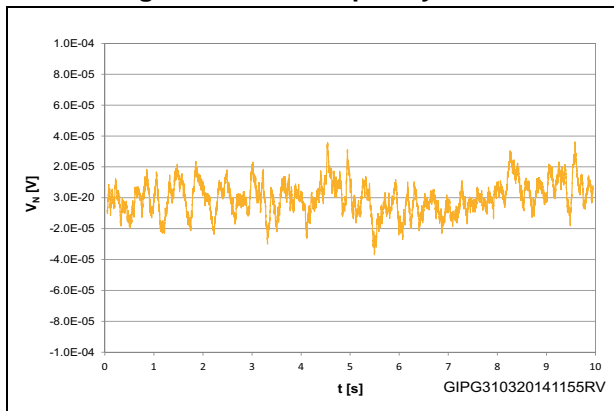

Figure 10. Low frequency noise



5 Package mechanical data

In order to meet environmental requirements, ST offers these devices in different grades of ECOPACK[®] packages, depending on their level of environmental compliance. ECOPACK[®] specifications, grade definitions and product status are available at: www.st.com. ECOPACK[®] is an ST trademark.

5.1 SOT23-3L, TS4061

Figure 11. SOT23-3L mechanical drawings

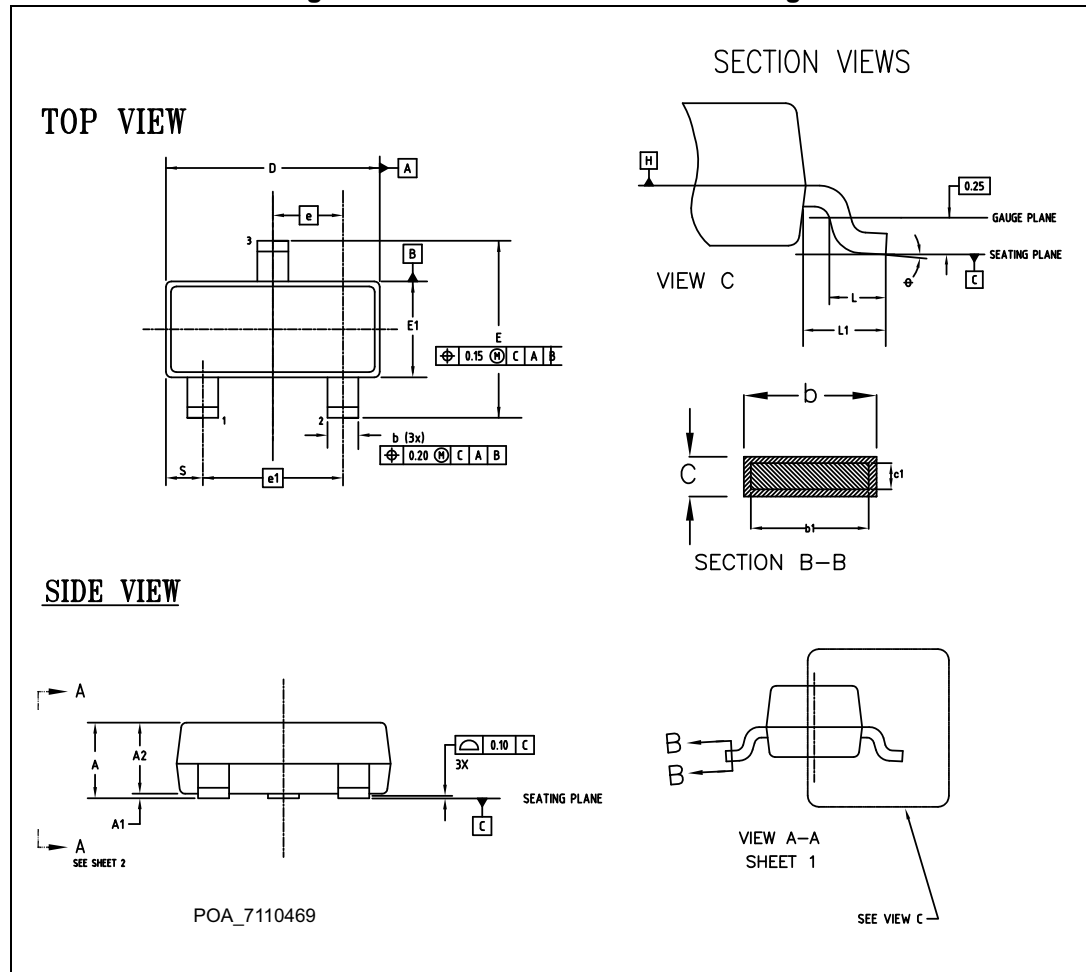
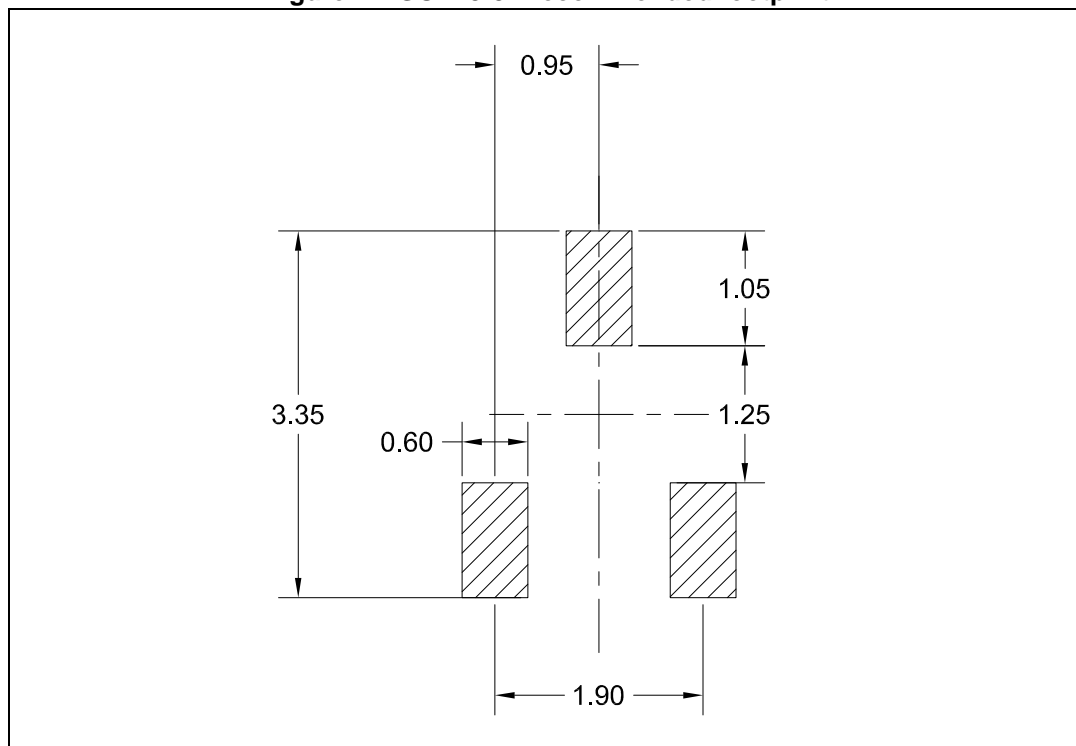

Table 5. SOT23-3L mechanical data

Dim.	mm		
	Min.	Typ.	Max.
A	0.89		1.12
A1	0.013		0.10
A2	0.88	0.95	1.02
b	0.37		0.50
b1	0.37	0.40	0.45
c	0.085		0.18
c1	0.085		0.16
D	2.80		3.04
E	2.10		2.64
E1	1.20		1.40
e	0.95 BSC		
e1	1.90 BSC		
*L	0.28	0.38	0.48
L1	0.55		
R	0.05		
R1	0.05		
θ	0°		8°
s	0.45		0.60

Figure 12. SOT23-3L recommended footprint



5.2 SOT323-3L, TS4061

Figure 13. SOT323-3L drawings

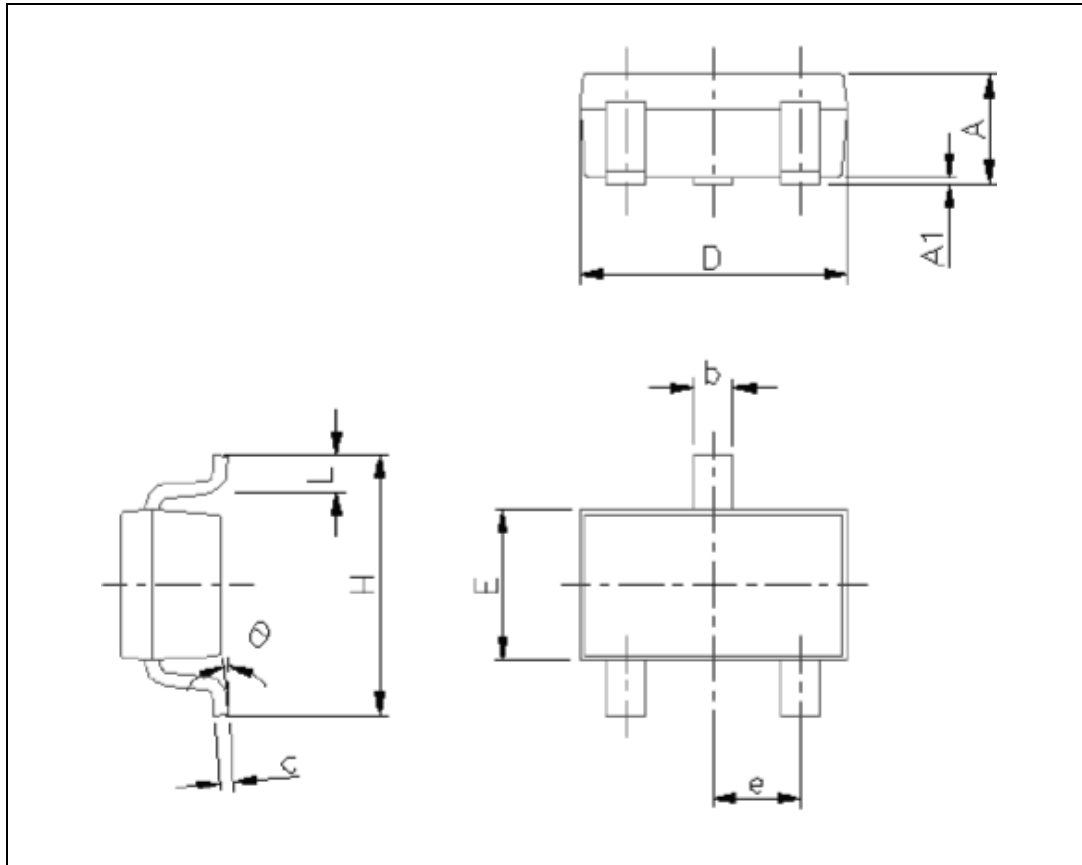
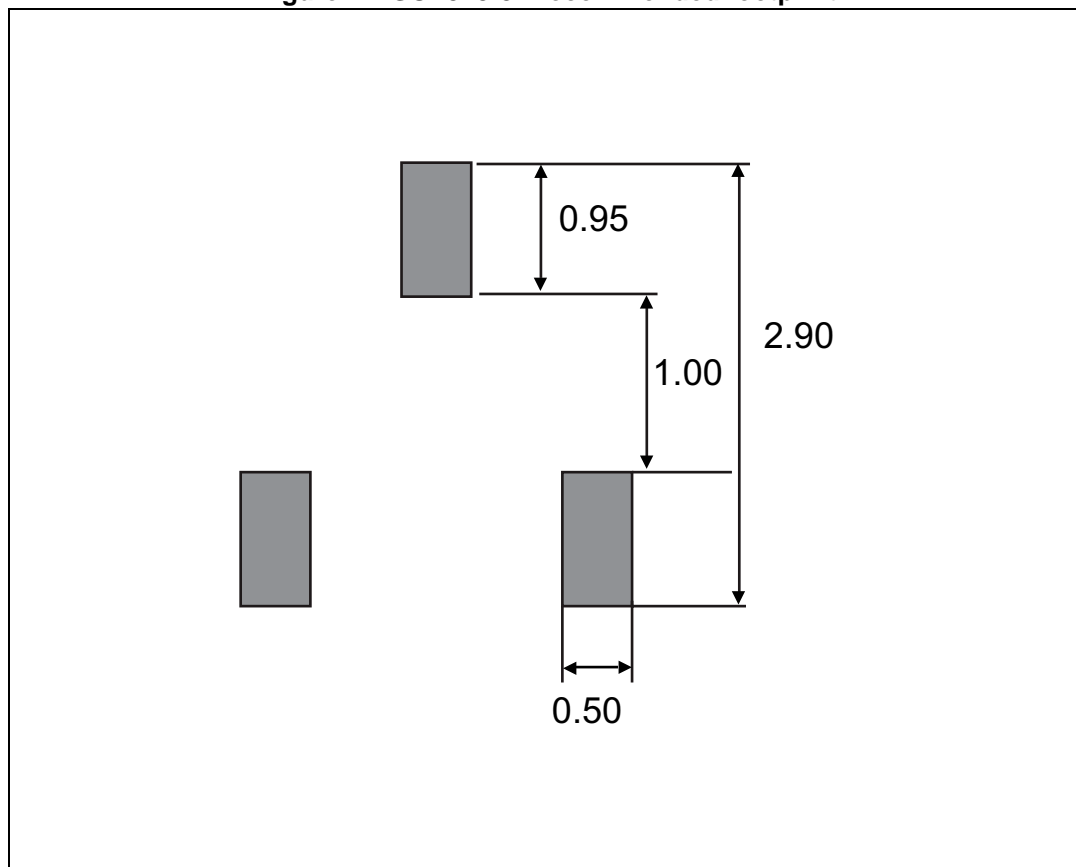

Table 6. SOT323-3L mechanical data

Dim.	mm		
	Typ.	Min.	Max.
A		0.80	1.10
A1		0.00	0.10
b		0.25	0.40
c		0.10	0.18
D		1.80	2.20
E		1.15	1.35
e	0.65	0.60	0.70
H		1.80	2.40
L		0.10	0.30

Figure 14. SOT323-3L recommended footprint



6 Ordering information

Table 7. Order codes

Order codes	Output voltage (V)	Precision (%)	Package	Temperature range (°C)
TS4061AILT-1.25	1.25	0.1	SOT23-3L	-40 to +85
TS4061AILT-1.225	1.225			
TS4061AICT-1.25	1.25	0.1	SOT323-3L	-40 to +85
TS4061AICT-1.225	1.225			
TS4061BILT-1.25	1.25	0.2	SOT23-3L	-40 to +85
TS4061BILT-1.225	1.225			
TS4061BICT-1.25	1.25	0.2	SOT323-3L	-40 to +85
TS4061BICT-1.225	1.225			

7 Revision history

Table 8. Document revision history

Date	Revision	Changes
21-Jul-2014	1	Initial release.
01-Feb-2018	2	Updated: <i>Table 5, Figure 11, Figure 12</i> and Note: <i>The NC pin must be left unconnected or connected to anode.</i>