

1.24 V adjustable shunt voltage reference

Features

- 1.24 V typical output voltage
- Ultra low operating current: 60 μ A maximum at 25° C
- High precision at 25° C:
 - +/- 1%
 - +/- 0.5%
- High stability when used with capacitive loads
- Industrial temperature range: -40° C to +85° C
- 100 ppm/°C temperature coefficient

Applications

- Computers
- Instrumentation
- Battery chargers
- Switch mode power supply
- Battery operated equipments

Description

The TS432 is an adjustable low power shunt voltage reference providing an output voltage from 1.24 V to 10 V over the industrial temperature range (-40° C to +85° C). Available in SOT23-3 surface mount package, it can be designed in applications where space saving is critical.

The low operating current is also a key advantage for power restricted designs. In addition, the TS432 is very stable and can be used in a broad range of application conditions.

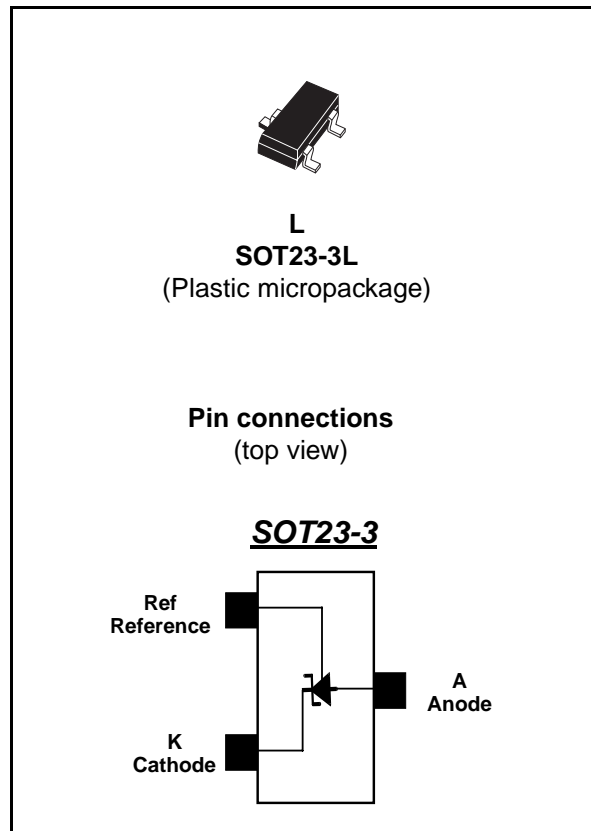

1 Absolute maximum ratings and operating conditions

Table 1. Absolute maximum ratings (AMR)

Symbol	Parameter	Value	Unit
V_K	Cathode voltage	12	V
I_K	Cathode current	-10 to +20	mA
I_{ref}	Reference input current	-0.05 to +3	mA
P_d	Power dissipation ⁽¹⁾ SOT23-3	340	mW
R_{thja}	Thermal resistance junction to ambient for SOT23-3	360	°C/W
T_{lead}	Lead temperature (soldering 10 seconds)	250	°C
T_{stg}	Storage temperature	-65 to +150	°C
T_j	Junction temperature	150	°C
ESD	HBM: human body model	1.5	kV
	MM: machine model	150	V

1. P_d is calculated with $T_{amb} = 25^\circ\text{C}$, $T_j = 150^\circ\text{C}$ and $R_{thja} = 360^\circ\text{C/W}$.

Table 2. Operating conditions

Symbol	Parameter	Value	Unit
V_K	Cathode voltage	1.24 to 10	V
I_K	Cathode current	60 μ to 12m	A
T_{amb}	Ambient temperature	-40 to +85	°C

2 Electrical characteristics

Table 3. $T_{amb} = 25^{\circ}\text{C}$ (unless otherwise specified)

Symbol	Parameter	Test conditions	Min.	Typ.	Max.	Unit
V_{ref}	Reference voltage	$I_K = 100\mu\text{A}$, $V_K = V_{REF}$		1.24		V
		TS432 (1%)	1.228		1.252	
		TS432A (0.5%)	1.234		1.246	
ΔV_{ref}	Reference voltage tolerance over temperature	$I_K = 100\mu\text{A}$, $V_K = V_{REF}$		7	16	mV
I_{Kmin}	Minimum operating current	$T_{amb} = 25^{\circ}\text{C}$		40	60	μA
		$-40^{\circ}\text{C} < T_{amb} < +85^{\circ}\text{C}$			65	
ΔV_{ref}	Reverse breakdown voltage change with operating current range	$I_{Kmin} < I_K < 1\text{mA}$		0.7	1.5	mV
		$-40^{\circ}\text{C} < T_{amb} < +85^{\circ}\text{C}$			2	
		$1\text{mA} < I_K < 12\text{mA}$		2	4	
		$-40^{\circ}\text{C} < T_{amb} < +85^{\circ}\text{C}$			6	
$\Delta V_{ref}/\Delta V_K$	Reference voltage change with output voltage change	$I_K = 10\text{mA}$, $V_K = 10\text{V}$ to V_{REF}		1.8	2.5	mV/V
		$-40^{\circ}\text{C} < T_{amb} < +85^{\circ}\text{C}$			3	
I_{ref}	Reference input current	$I_K = 10\text{mA}$, $R_1 = 10\text{k}\Omega$, $R_2 = +\infty$		50	100	nA
		$-40^{\circ}\text{C} < T_{amb} < +85^{\circ}\text{C}$			200	
I_{OFF}	Off-state cathode current	$V_{REF} = 0$, $V_K = 10\text{V}$		1	100	nA
		$-40^{\circ}\text{C} < T_{amb} < +85^{\circ}\text{C}$			150	
R_{KA}	Static impedance	$\Delta I_K = 100\mu\text{A}$ to 12mA		0.25	0.5	W
K_{VH}	Long term stability	$I_K = 100\mu\text{A}$, $t = 1000\text{hrs}$		120		ppm
E_N	Wide band noise	$I_K = 100\mu\text{A}$ $100\text{Hz} < F < 10\text{kHz}$		200		nV/ $\sqrt{\text{Hz}}$

Note: Limits are 100% production tested at 25°C . Behavior over the temperature range is guaranteed through correlation and by design.

Figure 1. Reference voltage vs temperature

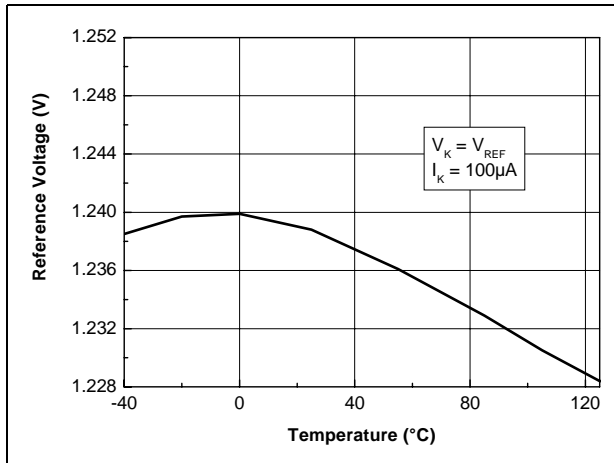

Figure 2. Test circuit for $V_K = V_{ref}$

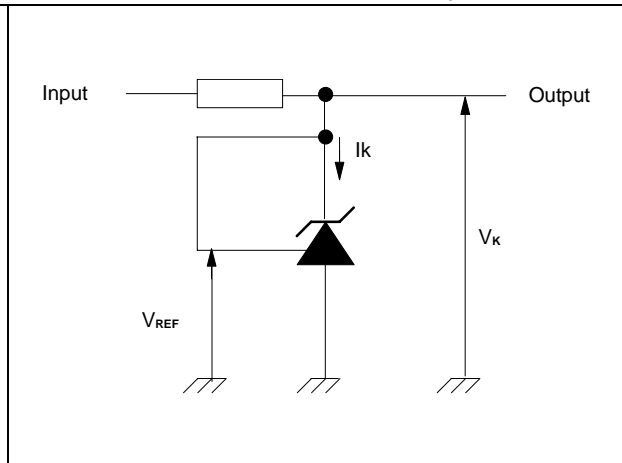

Figure 3. Cathode voltage vs cathode current

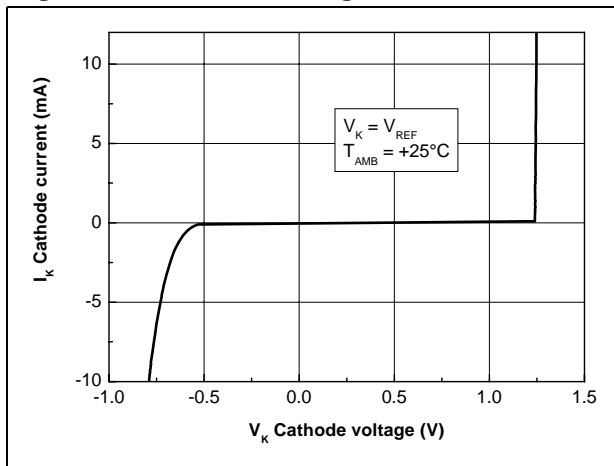

Figure 4. Cathode voltage vs cathode current

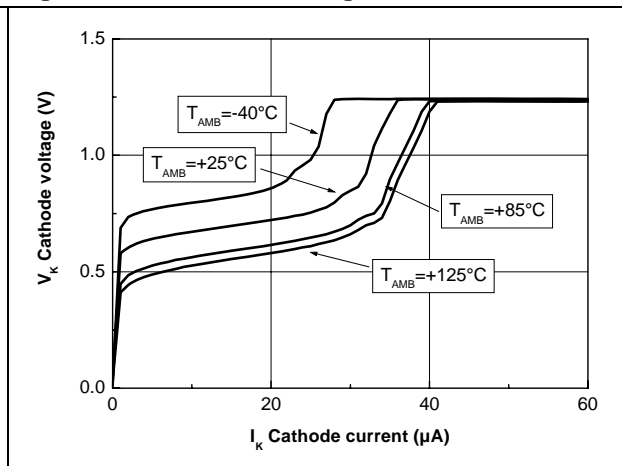

Figure 5. Reference input current vs temperature

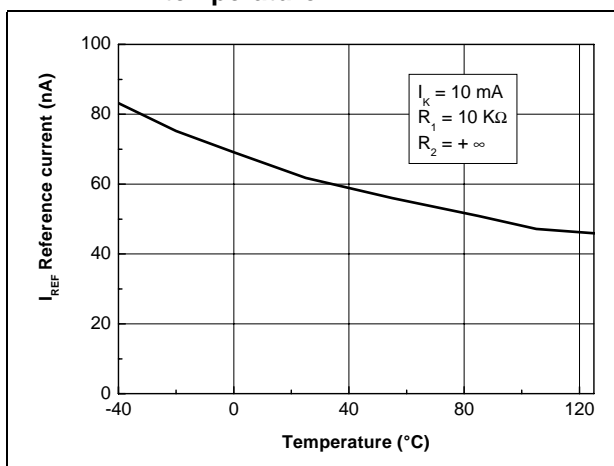

Figure 6. Static impedance vs temperature

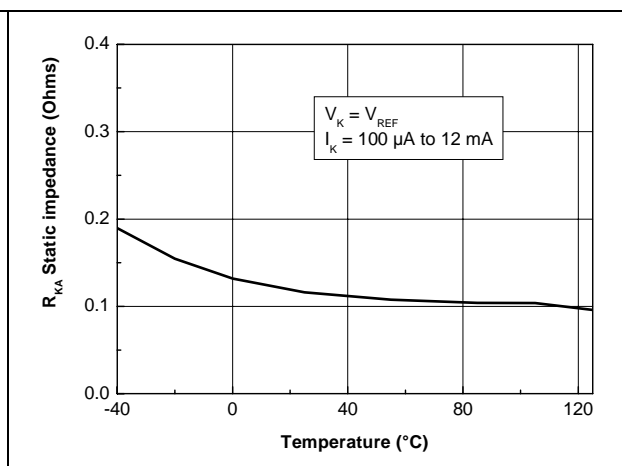

Figure 7. Off-state current vs temperature

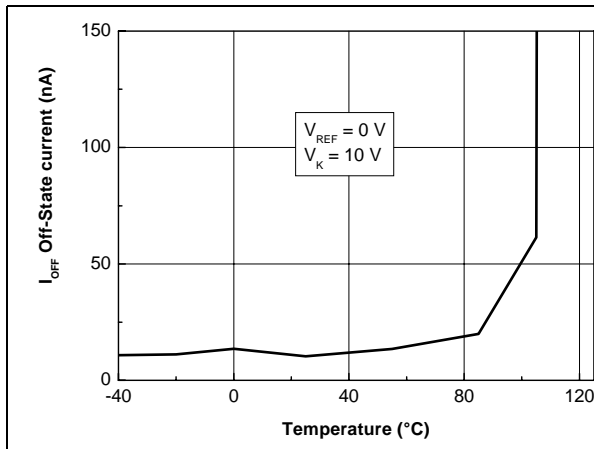

Figure 8. Test circuit for off-state current measurement

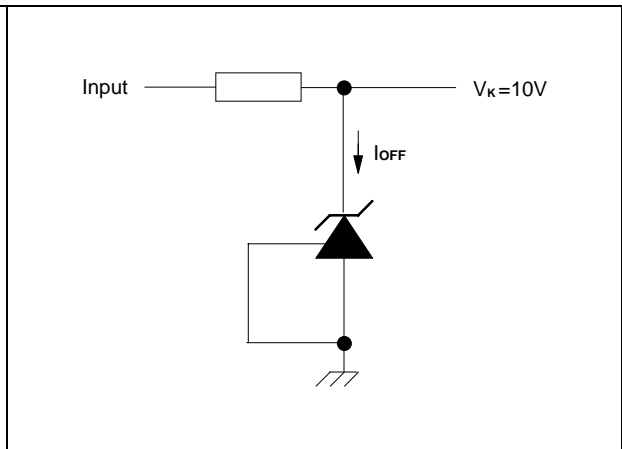

Figure 9. Ratio of change in reference input voltage to change in V_K voltage vs temperature

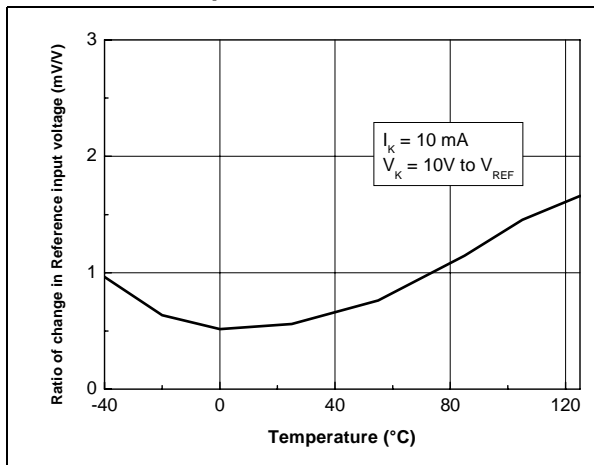

Figure 10. Test circuit for $V_{KA} > V_{REF}$

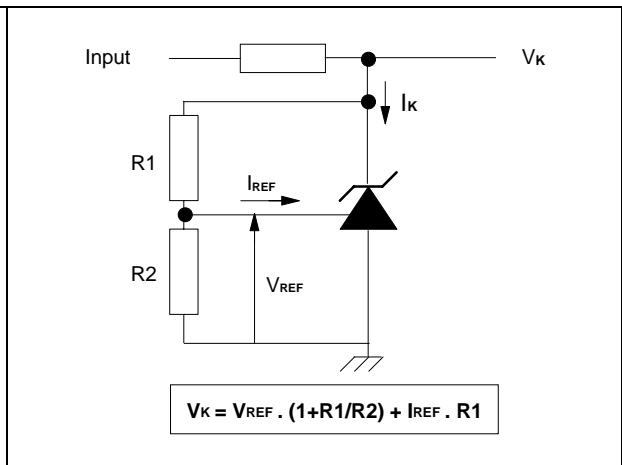

Figure 11. Phase and gain vs frequency

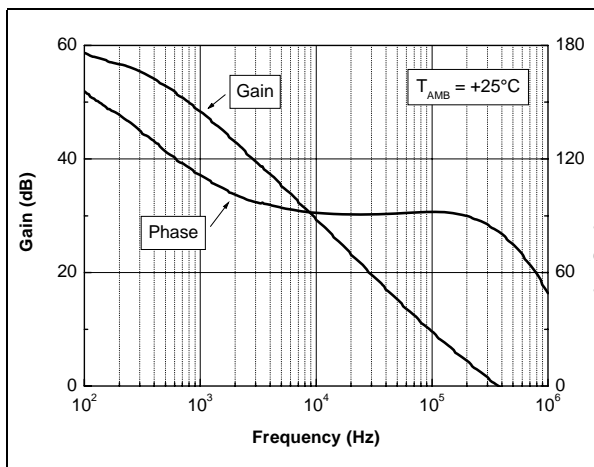

Figure 12. Test circuit for phase and gain measurement

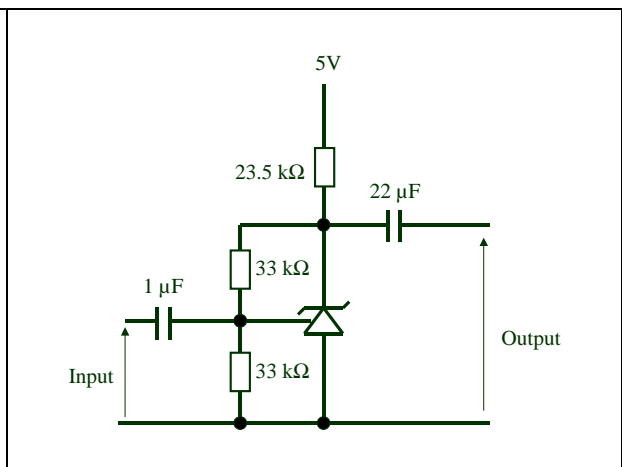

Figure 13. Test circuit for pulse response at $I_K=100\ \mu\text{A}$

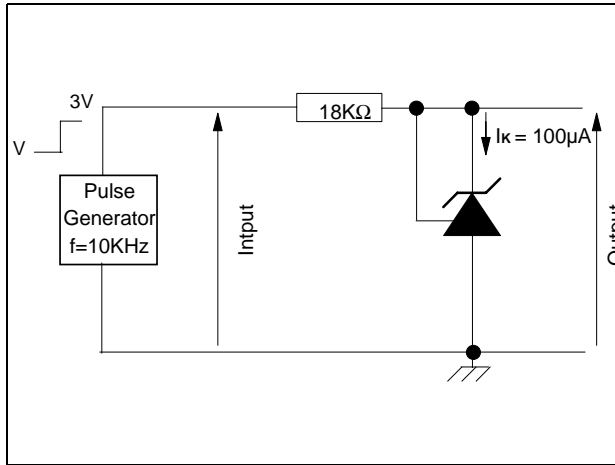

Figure 14. Test circuit for pulse response at $I_K = 1\ \text{mA}$

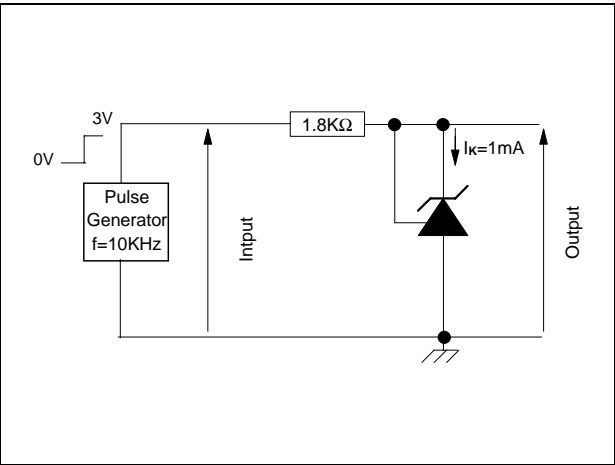

Figure 15. Pulse response at $I_K = 100\ \mu\text{A}$

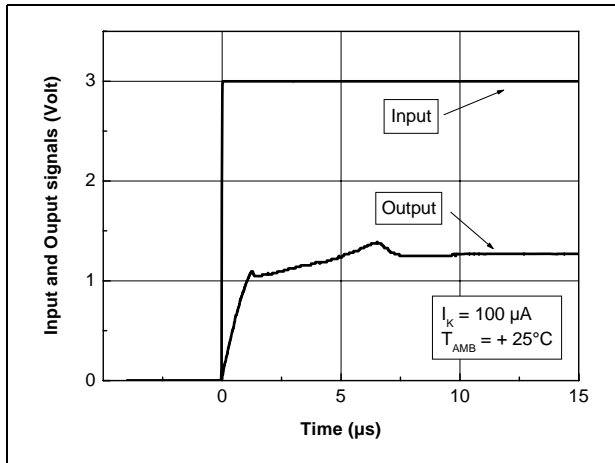

Figure 16. Pulse response at $I_K = 1\ \text{mA}$

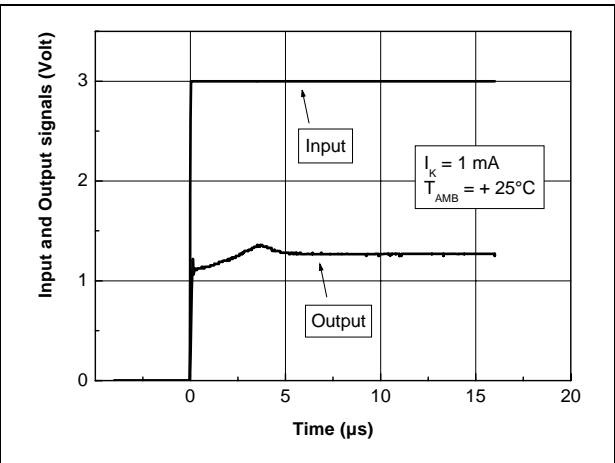

Figure 17. Pulse response at $I_K = 100\ \mu\text{A}$

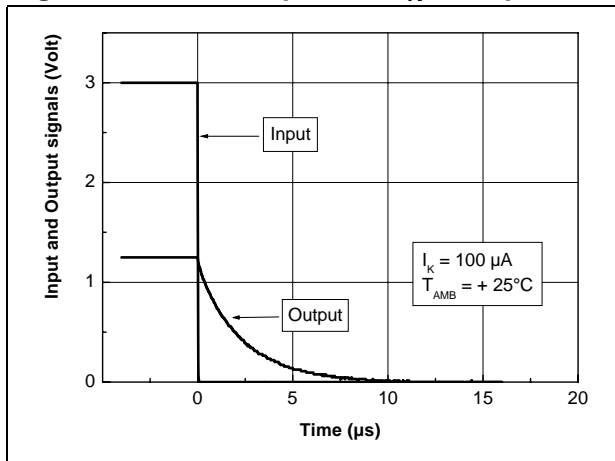

Figure 18. Pulse response at $I_K = 1\ \text{mA}$

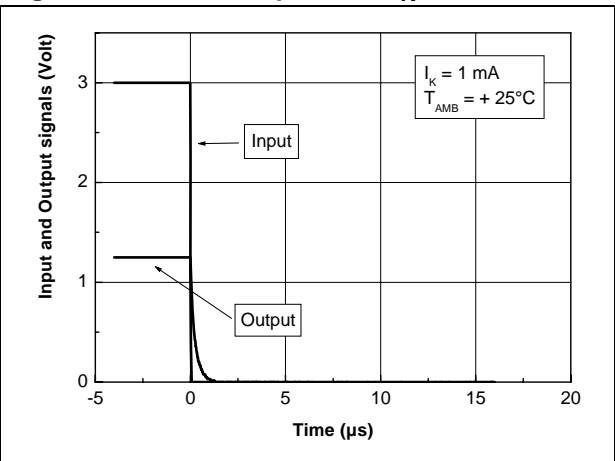

Figure 19. Equivalent input noise vs frequency

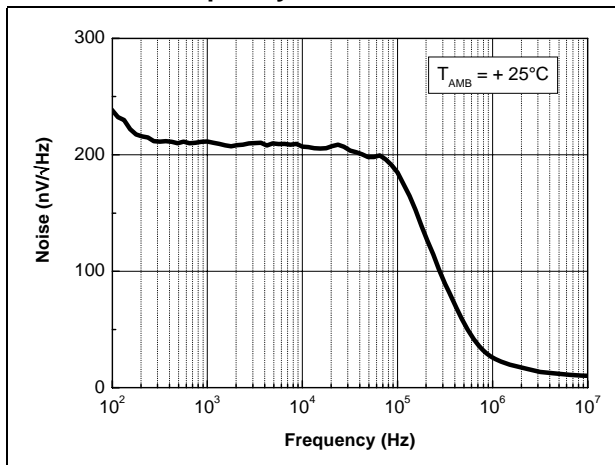
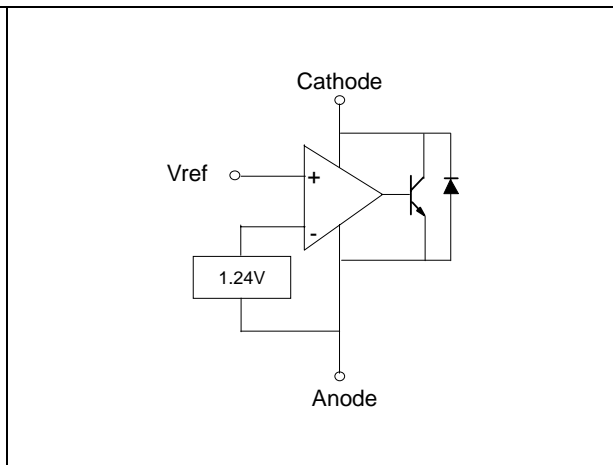

Figure 20. Block diagram



3 Package information

In order to meet environmental requirements, STMicroelectronics offers these devices in ECOPACK® packages. These packages have a lead-free second level interconnect. The category of second level interconnect is marked on the package and on the inner box label, in compliance with JEDEC Standard JESD97. The maximum ratings related to soldering conditions are also marked on the inner box label. ECOPACK is an STMicroelectronics trademark. ECOPACK specifications are available at: www.st.com.

Figure 21. SOT23-3 package mechanical drawing

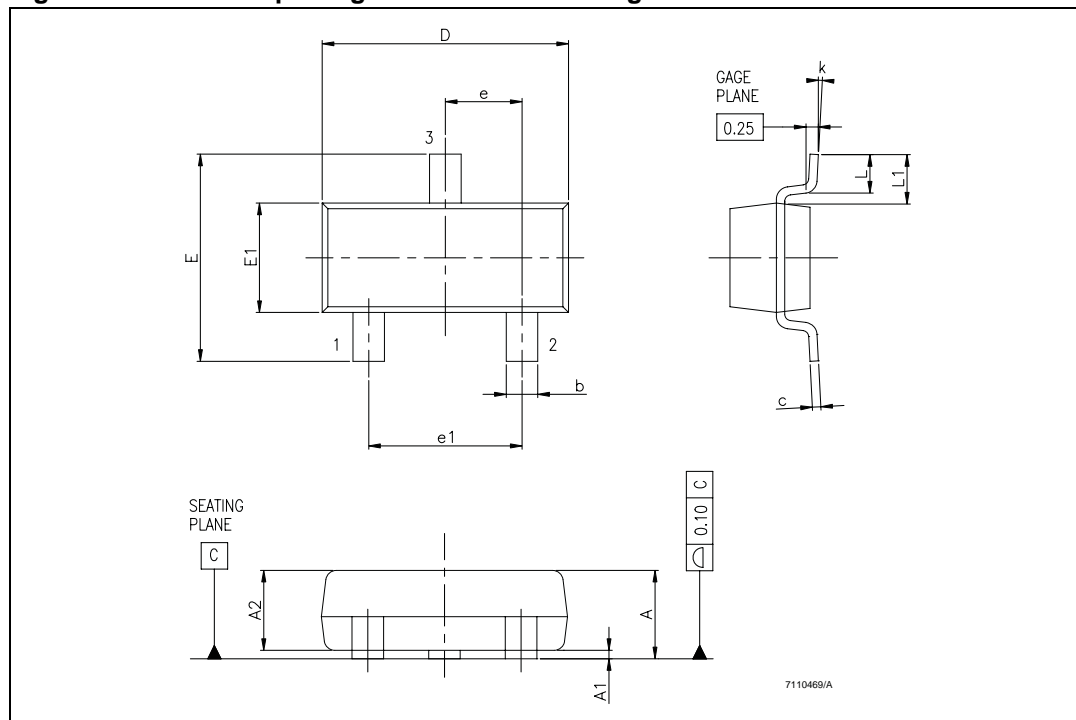

Table 4. SOT23-3 package mechanical data

Ref.	Dimensions					
	Millimeters			Mils		
	Min.	Typ.	Max.	Min.	Typ.	Max.
A	0.890		1.120	35.05		44.12
A1	0.010		0.100	0.39		3.94
A2	0.880	0.950	1.020	34.65	37.41	40.17
b	0.300		0.500	11.81		19.69
C	0.080		0.200	3.15		7.88
D	2.800	2.900	3.040	110.26	114.17	119.72
E	2.100		2.64	82.70		103.96
E1	1.200	1.300	1.400	47.26	51.19	55.13
e		0.950			37.41	
e1		1.900			74.82	
L	0.400		0.600	15.75		23.63
L1		0.540			21.27	
k	0°		8°	0°		8°

4 Ordering information

Table 5. Order codes

Precision	Order code	Temperature range	Package	Packing	Marking
1%	TS432ILT	-40° C to +85° C	SOT23-3	Tape & reel	L235
0.5%	TS432AILT				L236

5 Revision history

Table 6. Document revision history

Date	Revision	Changes
16-Dec-2002	1	Initial release.
7-Apr-2008	2	Corrected package mechanical data. Updated document format.