

Features

- Ultra low current consumption (6 μ A/comp. at $V_{CC} = 2.7$ V)
- Rail-to-rail CMOS inputs
- Push-pull outputs
- Supply operation from 2.7 to 10 V
- Low propagation delay
- ESD protection (2 kV)
- Latch-up immunity (class A)
- Available in SOT23-5 micropackage, SO-8, SO-14, TSSOP8, and TSSOP14 package

Applications

- Battery powered systems such as alarms
- Portable communication systems
- Smoke/gas/fire detectors
- Portable computers

Description

The TS86x device (single, dual and quad) is a rail-to-rail comparator characterized for 2.7 to 10 V operation over -40 °C to $+85$ °C temperature ranges. It exhibits an excellent speed-to-power ratio, featuring a current consumption of 6 μ A per comparator and a response time of 500 ns at 2.7 V for a 100 mV overdrive.

Due to its ultra low power consumption and its availability in a tiny package, the TS86x comparator family is perfectly suited to battery-powered systems. The output stage is designed with a push-pull structure allowing a direct connection to the microcontroller without additional pull-up resistors.

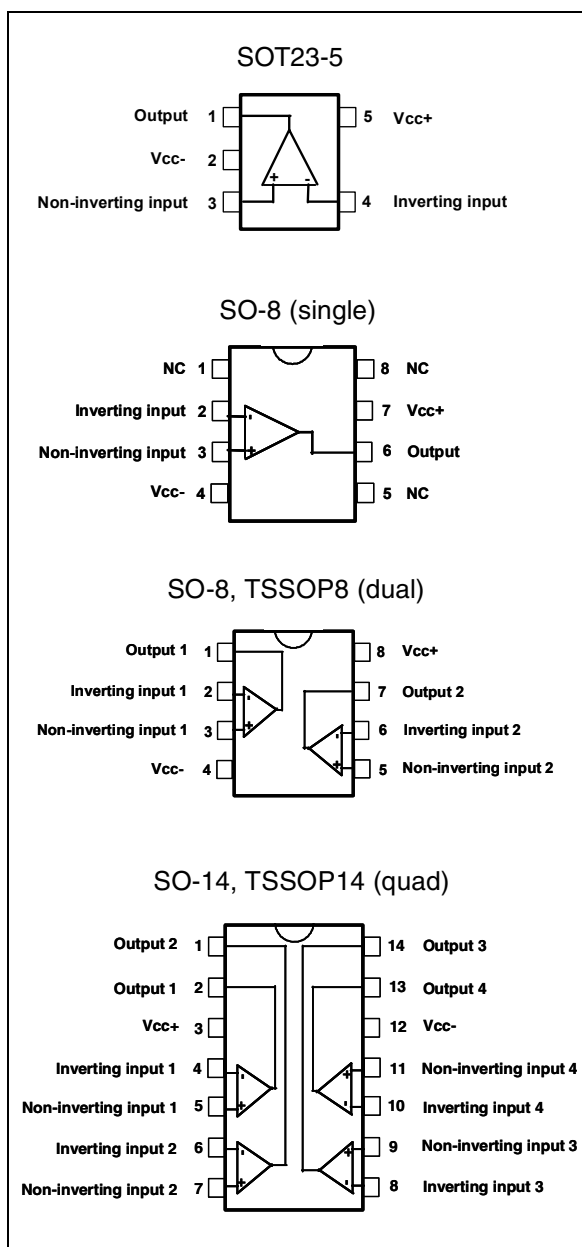

1 Absolute maximum ratings and operating conditions

Table 1. Absolute maximum ratings

Symbol	Parameter	Value	Unit
V _{CC}	Supply voltage ⁽¹⁾	12	V
V _{ID}	Differential input voltage ⁽²⁾	±12	V
V _{IN}	Input voltage range ⁽³⁾	-0.3 to 12.3	V
R _{THJA}	Thermal resistance junction-to-ambient ⁽⁴⁾		
	SOT23-5	250	°C/W
	SO-8	125	
	SO-14	105	
	TSSOP8	120	
TSSOP14	100		
R _{THJC}	Thermal resistance junction-to-case ⁽⁴⁾		
	SOT23-5	81	°C/W
	SO-8	40	
	SO-14	31	
	TSSOP8	37	
TSSOP14	32		
T _{STG}	Storage temperature range	-65 to +150	°C
T _J	Maximum junction temperature	150	°C
T _{LEAD}	Lead temperature (soldering, 10 sec.)	260	°C
ESD	Human body model (HBM) ⁽⁵⁾	2	kV
	Machine model (MM) ⁽⁶⁾	200	V
	Latch-up immunity	Class A	

1. All voltages values, except differential voltage are with respect to network terminal.
2. Differential voltages are non-inverting input terminal with respect to the inverting input terminal.
3. The magnitude of input and output voltages must never exceed V_{CC} +0.3 V.
4. Short-circuits can cause excessive heating. These values are typical.
5. Human body model: a 100 pF capacitor is charged to the specified voltage, then discharged through a 1.5 kΩ resistor between two pins of the device. This is done for all couples of connected pin combinations while the other pins are floating.
6. Machine model: a 200 pF capacitor is charged to the specified voltage, then discharged directly between two pins of the device with no external series resistor (internal resistor < 5 Ω). This is done for all couples of connected pin combinations while the other pins are floating.

Table 2. Operating conditions

Symbol	Parameter	Value	Unit
V _{CC}	Supply voltage	2.7 to 10	V
V _{ICM}	Common mode input voltage range	V _{CC} ⁻ - 0.3 to V _{CC} ⁺ + 0.3	V
T _{Oper}	Operating free air temperature range	-40 to + 85	°C

2 Electrical characteristics

**Table 3. Electrical characteristics at $V_{CC} = 2.7\text{ V}$, $T_{amb} = 25\text{ °C}$
(unless otherwise specified)**

Symbol	Parameter	Min.	Typ.	Max.	Unit
V_{IO}	Input offset voltage TS861/2/4 $T_{min} < T < T_{max}$		3	15 18	mV
	TS861/2/4A $T_{min} < T < T_{max}$		3	7 10	
ΔV_{IO}	Input offset voltage drift		6		$\mu\text{V}/\text{°C}$
I_{IO}	Input offset current ⁽¹⁾ $T_{min} < T < T_{max}$		1	150 300	pA
I_{IB}	Input bias current ⁽¹⁾ $T_{min} < T < T_{max}$		1	300 600	pA
V_{OH}	High level output voltage $I_{SOURCE} = 2.5\text{ mA}$ $T_{min} < T < T_{max}$	2.35 2.15	2.45		V
V_{OL}	Low level output voltage $I_{SINK} = 2.5\text{ mA}$ $T_{min} < T < T_{max}$		0.2	0.35 0.45	V
A_{VD}	Large signal voltage gain ⁽²⁾		240		dB
CMR	Common mode rejection ratio $0 < V_{ICM} < 2.7\text{ V}$		65		dB
SVR	Supply voltage rejection ratio $0 < V_{CC} < 10\text{ V}$		80		dB
I_{CC}	Supply current per comparator				
	No load, output low No load, output high		6 8	12 14	μA
T_{PLH}	Propagation delay from output low to output high $V_{ICM} = 1.35\text{ V}$, $f = 10\text{ kHz}$, $C_L = 50\text{ pF}$ Overdrive = 10 mV Overdrive = 100 mV		1.5 0.6		μs
T_{PHL}	Propagation delay from output high to output low $V_{ICM} = 1.35\text{ V}$, $f = 10\text{ kHz}$, $C_L = 50\text{ pF}$ Overdrive = 10 mV Overdrive = 100 mV		1.5 0.5		μs

**Table 3. Electrical characteristics at $V_{CC} = 2.7\text{ V}$, $T_{amb} = 25\text{ °C}$
(unless otherwise specified) (continued)**

Symbol	Parameter	Min.	Typ.	Max.	Unit
T_F	Fall time f = 10 kHz, $C_L = 50\text{ pF}$, overdrive = 100 mV		20		ns
T_R	Rise time f = 10 kHz, $C_L = 50\text{ pF}$, overdrive = 100 mV		20		ns

1. Maximum values including unavoidable inaccuracies of the industrial tests.
2. Design evaluation.

Note: Limits are 100% production tested at 25 °C. Limits over temperature are guaranteed through correlation and by design.

Table 4. Electrical characteristics at $V_{CC} = 5\text{ V}$, $T_{amb} = 25\text{ °C}$ (unless otherwise specified)

Symbol	Parameter	Min.	Typ.	Max.	Unit
V_{IO}	Input offset voltage TS861/2/4 $T_{min} < T < T_{max}$		3	15 18	mV
	TS861/2/4A $T_{min} < T < T_{max}$		3	7 10	
ΔV_{IO}	Input offset voltage drift		6		$\mu\text{V}/\text{°C}$
I_{IO}	Input offset current ⁽¹⁾ $T_{min} < T < T_{max}$		1	150 300	pA
I_{IB}	Input bias current ⁽¹⁾ $T_{min} < T < T_{max}$		1	300 600	pA
V_{OH}	High level output voltage $I_{SOURCE} = 5\text{ mA}$ $T_{min} < T < T_{max}$	4.6 4.45	4.8		V
V_{OL}	Low level output voltage $I_{SINK} = 5\text{ mA}$ $T_{min} < T < T_{max}$		0.2	0.4 0.55	V
A_{VD}	Large signal voltage gain ⁽²⁾		240		dB
CMR	Common mode rejection ratio $0 < V_{ICM} < 5\text{ V}$		70		dB
SVR	Supply voltage rejection ratio $2.7 < V_{CC} < 10\text{ V}$		80		dB
I_{CC}	Supply current per comparator				μA
	No load, output low No load, output high		6 8	12 14	
T_{PLH}	Propagation delay from output low to output high $V_{ICM} = 2.5\text{ V}$, $f = 10\text{ kHz}$, $C_L = 50\text{ pF}$ Overdrive = 10 mV Overdrive = 100 mV		2 0.5		μs
T_{PHL}	Propagation delay from output high to output low $V_{ICM} = 2.5\text{ V}$, $f = 10\text{ kHz}$, $C_L = 50\text{ pF}$ Overdrive = 10 mV Overdrive = 100 mV		2 0.4		μs
T_F	Fall time $f = 10\text{ kHz}$, $C_L = 50\text{ pF}$, overdrive = 100 mV		20		ns
T_R	Rise time $f = 10\text{ kHz}$, $C_L = 50\text{ pF}$, overdrive = 100 mV		20		ns

1. Maximum values including unavoidable inaccuracies of the industrial test.

2. Design evaluation.

Note: Limits are 100% production tested at 25 °C. Limits over temperature are guaranteed through correlation and by design.

Table 5. Electrical characteristics at $V_{CC} = +10\text{ V}$, $T_{amb} = 25\text{ °C}$ (unless otherwise specified)

Symbol	Parameter	Min.	Typ.	Max.	Unit
V_{IO}	Input offset voltage ($V_{ICM} = V_{CC} / 2$) TS861/2/4 $T_{min} < T < T_{max}$		3	15 18	mV
ΔV_{IO}	Input offset voltage drift		6		$\mu\text{V}/\text{°C}$
I_{IO}	Input offset current ⁽¹⁾ $T_{min} < T < T_{max}$		1	150 300	pA
I_{IB}	Input bias current ⁽¹⁾ $T_{min} < T < T_{max}$		1	300 600	pA
V_{OH}	High level output voltage $I_{SOURCE} = 5\text{ mA}$ $T_{min} < T < T_{max}$	9.6 9.45	9.8		V
V_{OL}	Low level output voltage $I_{SINK} = 5\text{ mA}$ $T_{min} < T < T_{max}$		0.2	0.4 0.55	V
A_{VD}	Large signal voltage gain ⁽²⁾		240		dB
CMR	Common mode rejection ratio $0 < V_{ICM} < 10\text{ V}$		75		dB
SVR	Supply voltage rejection ratio $2.7 < V_{CC} < 10\text{ V}$		80		dB
I_{CC}	Supply current per comparator No load, output low No load, output high		7 10	14 16	μA
T_{PLH}	Propagation delay from output low to output high $V_{ICM} = 5\text{ V}$, $f = 10\text{ kHz}$, $C_L = 50\text{ pF}$ Overdrive = 10 mV Overdrive = 100 mV		3 0.5		μs
T_{PHL}	Propagation delay from output high to output low $V_{ICM} = 5\text{ V}$, $f = 10\text{ kHz}$, $C_L = 50\text{ pF}$ Overdrive = 10 mV Overdrive = 100 mV		2.6 0.4		μs
T_F	Fall time $f = 10\text{ kHz}$, $C_L = 50\text{ pF}$, overdrive = 100 mV		20		ns
T_R	Rise time $f = 10\text{ kHz}$, $C_L = 50\text{ pF}$, overdrive = 100 mV		20		ns

1. Maximum values including unavoidable inaccuracies of the industrial test.

2. Design evaluation.

Note: Limits are 100% production tested at 25 °C. Limits over temperature are guaranteed through correlation and by design.

Figure 1. V_{IO} vs. V_{ICM} at $V_{CC} = 2.7\text{ V}$



Figure 2. V_{IO} vs. V_{ICM} and temperature at $V_{CC} = 2.7\text{ V}$



Figure 3. V_{IO} vs. V_{ICM} at $V_{CC} = 5\text{ V}$



Figure 4. V_{IO} vs. V_{ICM} and temperature at $V_{CC} = 5\text{ V}$



Figure 5. V_{IO} vs. V_{ICM} at $V_{CC} = 10\text{ V}$



Figure 6. V_{IO} vs. V_{ICM} and temperature at $V_{CC} = 10\text{ V}$



Figure 7. V_{IO} vs. V_{CC} at $V_{ICM} = V_{CC}/2$



Figure 8. V_{IO} vs. temperature at $V_{CC} = 5$ V

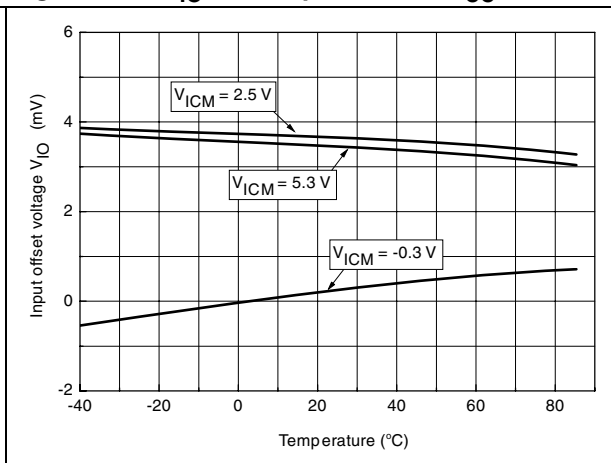

Figure 9. Supply current (I_{CC}) vs. supply voltage (V_{CC}) ($V_{ID} = -1$ V)



Figure 10. Supply current (I_{CC}) vs. supply voltage (V_{CC}) ($V_{ID} = +1$ V)

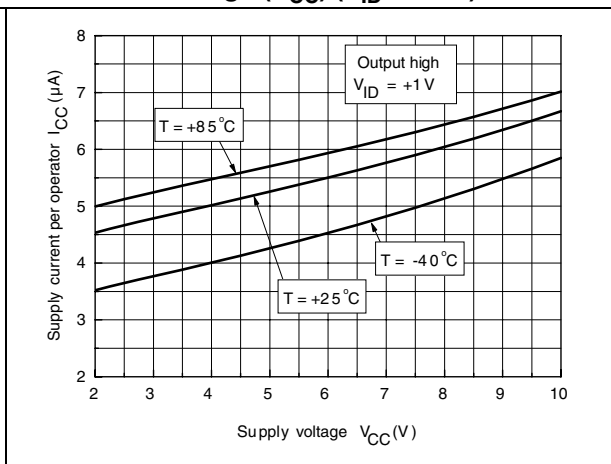

Figure 11. Supply current (I_{CC}) vs. temperature ($V_{ID} = -1$ V)

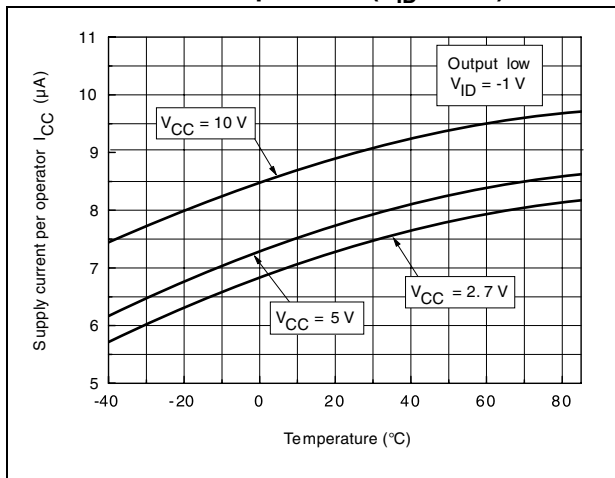

Figure 12. Supply current (I_{CC}) vs. temperature ($V_{ID} = +1$ V)

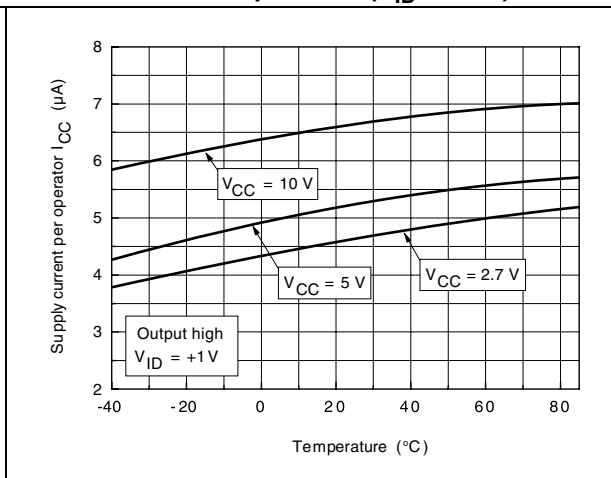

Figure 13. V_{OL} vs. I_{SINK} and temperature at $V_{CC} = 5 V$



Figure 14. V_{OH} vs. I_{SOURCE} and temperature at $V_{CC} = 5 V$



Figure 15. Propagation delay T_{PLH} vs. V_{ICM} with $V_{OVD} = 100 mV$



Figure 16. Propagation delay T_{PHL} vs. V_{ICM} with $V_{OVD} = 100 mV$



Figure 17. Propagation delay T_{PLH} vs. V_{ICM} with $V_{OVD} = 10 mV$



Figure 18. Propagation delay T_{PHL} vs. V_{ICM} with $V_{OVD} = 10 mV$



Figure 19. Propagation delay vs. V_{CC} with $V_{OVD} = 10\text{ mV}$



Figure 20. Propagation delay vs. V_{CC} with $V_{OVD} = 100\text{ mV}$



Figure 21. Propagation delay vs. overdrive voltage at $V_{CC} = 2.7\text{ V}$



Figure 22. Propagation delay vs. overdrive voltage at $V_{CC} = 5\text{ V}$



Figure 23. Propagation delay vs. overdrive voltage at $V_{CC} = 10\text{ V}$



3 Package information

In order to meet environmental requirements, ST offers these devices in different grades of ECOPACK® packages, depending on their level of environmental compliance. ECOPACK specifications, grade definitions and product status are available at: www.st.com. ECOPACK is an ST trademark.

3.1 SOT23-5 package information

Figure 24. SOT23-5L package outline

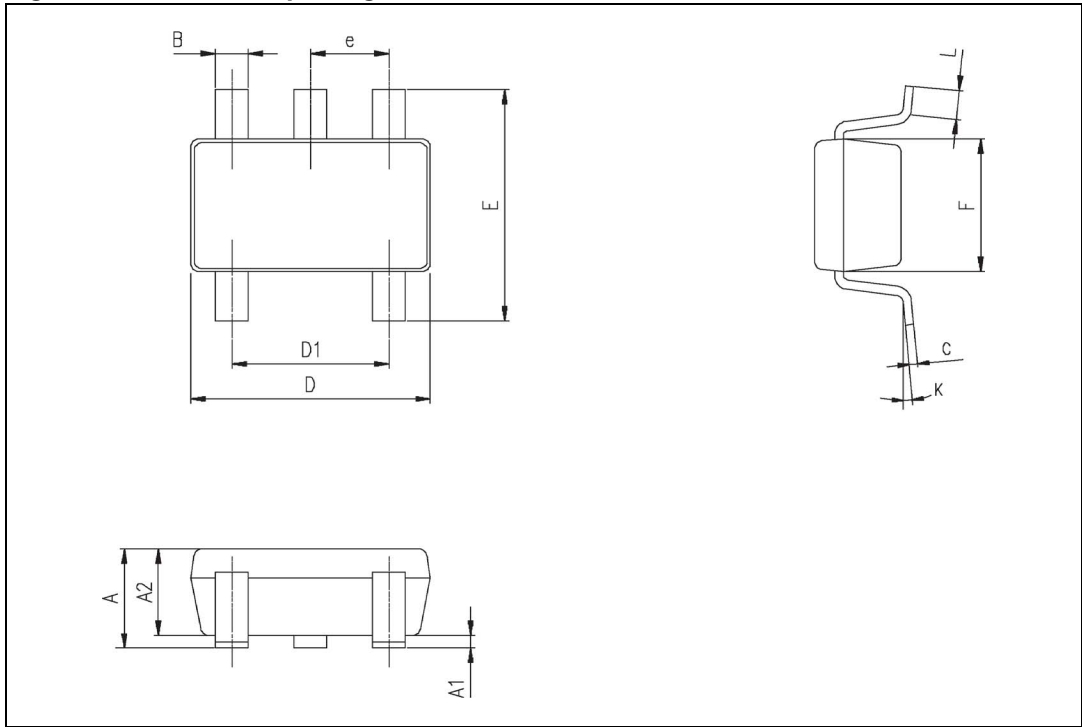

Table 6. SOT23-5L package mechanical data

Symbol	Dimensions					
	Millimeters			Inches		
	Min.	Typ.	Max.	Min.	Typ.	Max.
A	0.90	1.20	1.45	0.035	0.047	0.057
A1			0.15			0.006
A2	0.90	1.05	1.30	0.035	0.041	0.051
B	0.35	0.40	0.50	0.013	0.015	0.019
C	0.09	0.15	0.20	0.003	0.006	0.008
D	2.80	2.90	3.00	0.110	0.114	0.118
D1		1.90			0.075	
e		0.95			0.037	
E	2.60	2.80	3.00	0.102	0.110	0.118
F	1.50	1.60	1.75	0.059	0.063	0.069
L	0.10	0.35	0.60	0.004	0.013	0.023
K	0°		10°			

3.2 SO-8 package information

Figure 25. SO-8 package outline

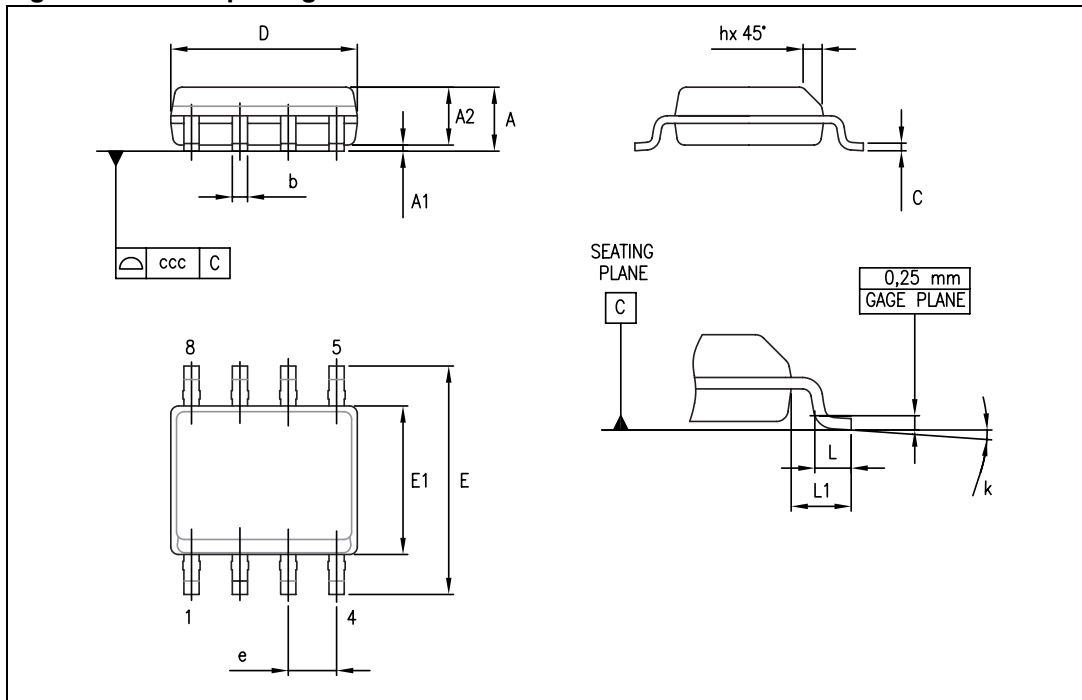

Table 7. SO-8 package mechanical data

Symbol	Dimensions					
	Millimeters			Inches		
	Min.	Typ.	Max.	Min.	Typ.	Max.
A			1.75			0.069
A1	0.10		0.25	0.004		0.010
A2	1.25			0.049		
b	0.28		0.48	0.011		0.019
c	0.17		0.23	0.007		0.010
D	4.80	4.90	5.00	0.189	0.193	0.197
E	5.80	6.00	6.20	0.228	0.236	0.244
E1	3.80	3.90	4.00	0.150	0.154	0.157
e		1.27			0.050	
h	0.25		0.50	0.010		0.020
L	0.40		1.27	0.016		0.050
L1		1.04			0.040	
k	0		8°	1°		8°
ccc			0.10			0.004

3.3 SO-14 package information

Figure 26. SO-14 package outline

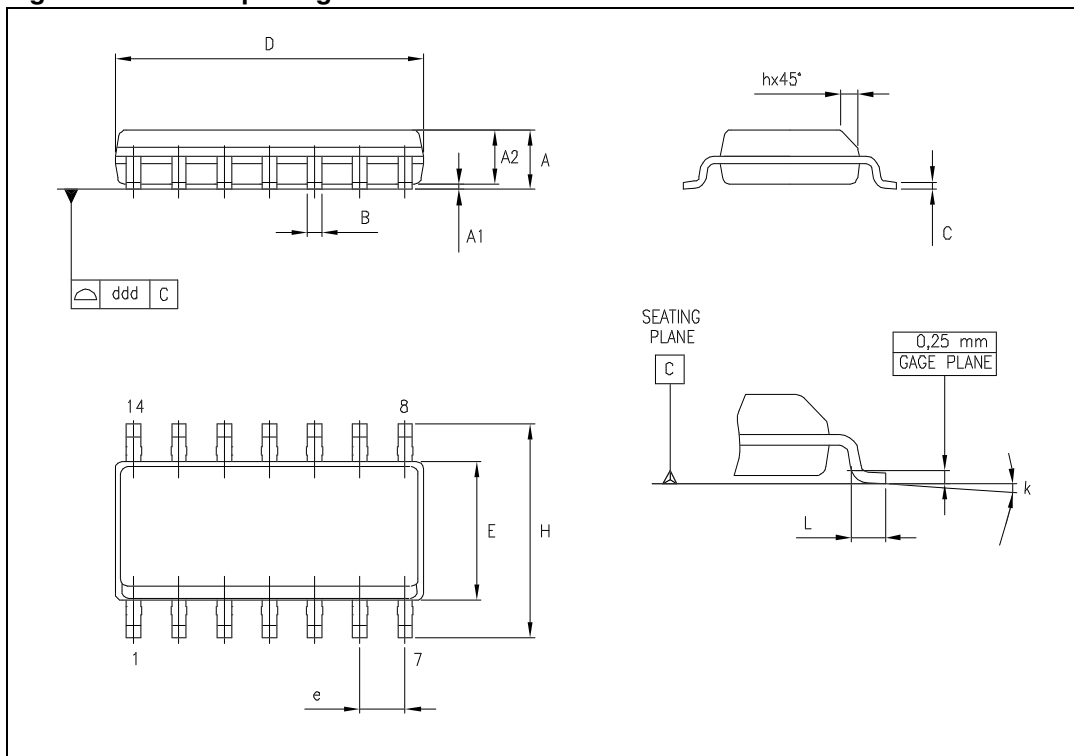

Table 8. SO-14 package mechanical data

Symbol	Dimensions					
	Millimeters			Inches		
	Min.	Typ.	Max.	Min.	Typ.	Max.
A	1.35		1.75	0.05		0.068
A1	0.10		0.25	0.004		0.009
A2	1.10		1.65	0.04		0.06
B	0.33		0.51	0.01		0.02
C	0.19		0.25	0.007		0.009
D	8.55		8.75	0.33		0.34
E	3.80		4.0	0.15		0.15
e		1.27			0.05	
H	5.80		6.20	0.22		0.24
h	0.25		0.50	0.009		0.02
L	0.40		1.27	0.015		0.05
k	8° (max.)					
ddd			0.10			0.004

3.4 TSSOP8 package information

Figure 27. TSSOP8 package outline

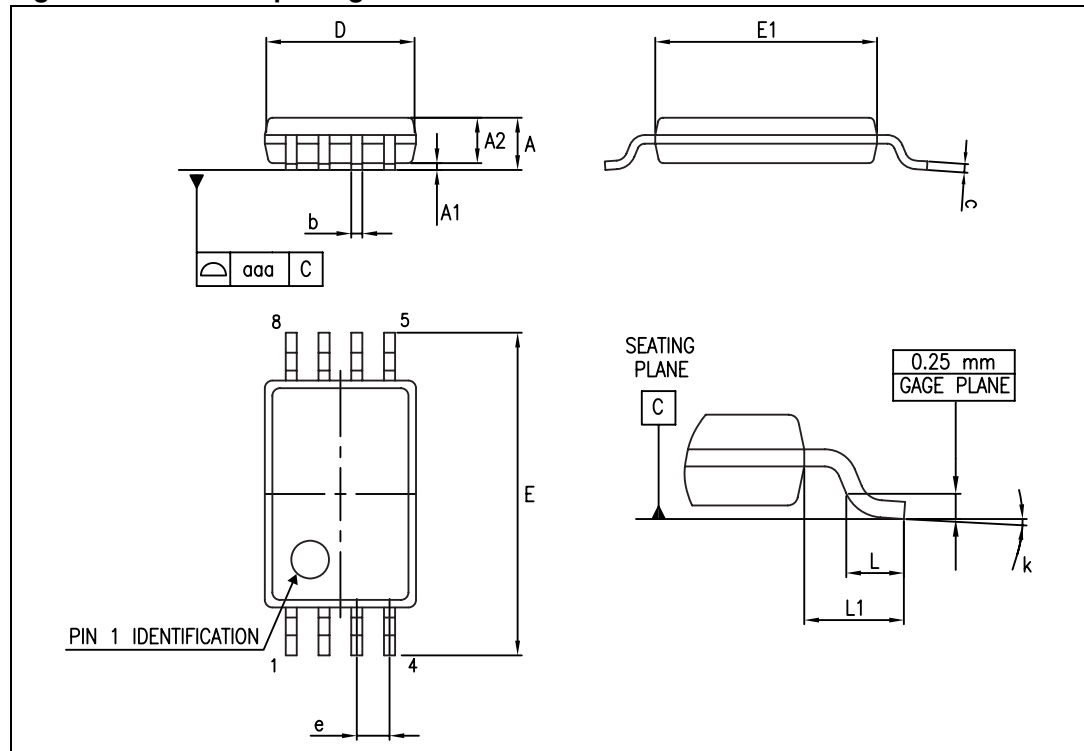

Table 9. TSSOP8 package mechanical data

Symbol	Dimensions					
	Millimeters			Inches		
	Min.	Typ.	Max.	Min.	Typ.	Max.
A			1.20			0.047
A1	0.05		0.15	0.002		0.006
A2	0.80	1.00	1.05	0.031	0.039	0.041
b	0.19		0.30	0.007		0.012
c	0.09		0.20	0.004		0.008
D	2.90	3.00	3.10	0.114	0.118	0.122
E	6.20	6.40	6.60	0.244	0.252	0.260
E1	4.30	4.40	4.50	0.169	0.173	0.177
e		0.65			0.0256	
k	0°		8°	0°		8°
L	0.45	0.60	0.75	0.018	0.024	0.030
L1		1			0.039	
aaa			0.10			0.004

3.5 TSSOP14 package information

Figure 28. TSSOP14 package outline



Table 10. TSSOP14 package mechanical data

Symbol	Dimensions					
	Millimeters			Inches		
	Min.	Typ.	Max.	Min.	Typ.	Max.
A			1.20			0.047
A1	0.05		0.15	0.002	0.004	0.006
A2	0.80	1.00	1.05	0.031	0.039	0.041
b	0.19		0.30	0.007		0.012
c	0.09		0.20	0.004		0.0089
D	4.90	5.00	5.10	0.193	0.197	0.201
E	6.20	6.40	6.60	0.244	0.252	0.260
E1	4.30	4.40	4.50	0.169	0.173	0.176
e		0.65			0.0256	
L	0.45	0.60	0.75	0.018	0.024	0.030
L1		1.00			0.039	
k	0°		8°	0°		8°
aaa			0.10			0.004

4 Ordering information

Table 11. Order codes

Part number	Temperature range	Package	Packaging	Marking
TS861ILT TS861AILT	-40 °C, +85 °C	SOT-23	Tape and reel	K501 K502
TS861ID TS861IDT		SO-8	Tube Tape and reel	861I
TS861AID TS861AIDT			Tube Tape and reel	861AI
TS862ID TS862IDT	-40 °C, +85 °C	SO-8	Tube Tape and reel	862I
TS862AID TS862AIDT			Tube Tape and reel	862AI
TS862IPT TS862AIPT		TSSOP8	Tape and reel	862I 862AI
TS864ID TS864IDT	-40 °C, +85 °C	SO-14	Tube Tape and reel	864I
TS864AID TS864AIDT			Tube Tape and reel	864AI
TS864IPT TS864AIPT		TSSOP14	Tape and reel	864I 864AI

5 Revision history

Table 12. Document revision history

Date	Revision	Changes
01-Feb-2002	1	Initial release.
28-Apr-2009	2	Updated document format. Removed power dissipation from Table 1: Absolute maximum ratings . Added Rthja and Rthjc values and ESD notes in Table 1 . Updated curves in Figure 1 to Figure 14 . Changed Figure 15 , Figure 16 , Figure 17 and Figure 18 . Added Figure 19 , Figure 20 , Figure 21 , Figure 22 and Figure 23 . Removed DIP package information in Chapter 3 and Chapter 4 . Added ordering information in Table 11: Order codes .
06-Nov-2012	3	Updated titles of Figure 9 to Figure 12 (added conditions). Removed TS861IYLT, TS861AIYLT, TS862IYDT, TS862AIYDT, TS864IYDT, and TS864AIYDT order codes from Table 11 . Minor corrections throughout document.