

## 30A, 100V - 200V Trench Schottky Rectifier

### FEATURES

- Patented Trench Schottky technology
- Excellent high temperature stability
- Low forward voltage
- Low power loss/ High efficiency
- High forward surge capability
- RoHS Compliant
- Halogen-free according to IEC 61249-2-21

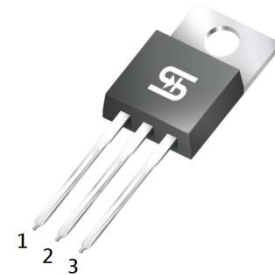
### APPLICATIONS

- Switching mode power supply (SMPS)
- Adapters
- DC to DC converters

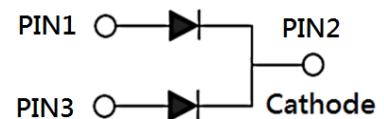
### MECHANICAL DATA

- Case: TO-220AB
- Molding compound meets UL 94V-0 flammability rating
- Terminal: Matte tin plated leads, solderable per J-STD-002
- Mounting torque: 0.56 N·m maximum
- Meet JESD 201 class 1A whisker test
- Polarity: As marked
- Weight: 1.88g (approximately)

KEY PARAMETERS		
PARAMETER	VALUE	UNIT
$I_F$	30	A
$V_{RRM}$	100 - 200	V
$I_{FSM}$	200	A
$T_{J\ MAX}$	150	°C
Package	TO-220AB	
Configuration	Dual dies	



TO-220AB



ABSOLUTE MAXIMUM RATINGS ( $T_A = 25^\circ\text{C}$ unless otherwise noted)						
PARAMETER	SYMBOL	TST30L 100CW	TST30L 120CW	TST30L 150CW	TST30L 200CW	UNIT
Marking code on the device		TST30L 100CW	TST30L 120CW	TST30L 150CW	TST30L 200CW	
Repetitive peak reverse voltage	$V_{RRM}$	100	120	150	200	V
Reverse voltage, total rms value	$V_{R(RMS)}$	70	84	105	140	V
Forward current	$I_F$	30				A
Surge peak forward current, 8.3ms single half sine wave superimposed on rated load	$I_{FSM}$	200				A
Critical rate of rise of off-state voltage	dv/dt	10,000				V/ $\mu\text{s}$
Junction temperature	$T_J$	-55 to +150				°C
Storage temperature	$T_{STG}$	-55 to +150				°C

<b>THERMAL PERFORMANCE</b>				
<b>PARAMETER</b>		<b>SYMBOL</b>	<b>TYP</b>	<b>UNIT</b>
Junction-to-lead thermal resistance	TST30L100CW TST30L120CW	$R_{\theta JL}$	3.5	$^{\circ}\text{C/W}$
	TST30L150CW TST30L200CW		3.8	$^{\circ}\text{C/W}$
Junction-to-case thermal resistance	TST30L100CW TST30L120CW	$R_{\theta JC}$	2.5	$^{\circ}\text{C/W}$
	TST30L150CW TST30L200CW		2.8	$^{\circ}\text{C/W}$

<b>ELECTRICAL SPECIFICATIONS</b> ( $T_A = 25^{\circ}\text{C}$ unless otherwise noted)						
<b>PARAMETER</b>		<b>CONDITIONS</b>	<b>SYMBOL</b>	<b>TYP</b>	<b>MAX</b>	<b>UNIT</b>
Forward voltage per diode <sup>(1)</sup>	TST30L100CW	$I_F = 15\text{A}, T_J = 25^{\circ}\text{C}$	$V_F$	0.76	0.82	V
	TST30L120CW			0.82	0.88	V
	TST30L150CW			0.84	0.92	V
	TST30L200CW			0.86	0.96	V
	TST30L100CW	$I_F = 15\text{A}, T_J = 125^{\circ}\text{C}$		0.65	0.71	V
	TST30L120CW			0.67	0.75	V
	TST30L150CW			0.70	0.78	V
	TST30L200CW			0.73	0.81	V
Reverse current @ rated $V_R$ per diode <sup>(2)</sup>	TST30L100CW TST30L120CW	$T_J = 25^{\circ}\text{C}$	$I_R$	-	200	$\mu\text{A}$
	TST30L150CW TST30L200CW	-		100	$\mu\text{A}$	
	TST30L100CW TST30L120CW	$T_J = 125^{\circ}\text{C}$		-	20	mA
	TST30L150CW TST30L200CW	-		15	mA	

**Notes:**

1. Pulse test with  $PW = 0.3\text{ms}$
2. Pulse test with  $PW = 30\text{ms}$

<b>ORDERING INFORMATION</b>		
<b>ORDERING CODE<sup>(1)</sup></b>	<b>PACKAGE</b>	<b>PACKING</b>
TST30LxCW	TO-220AB	50 / Tube

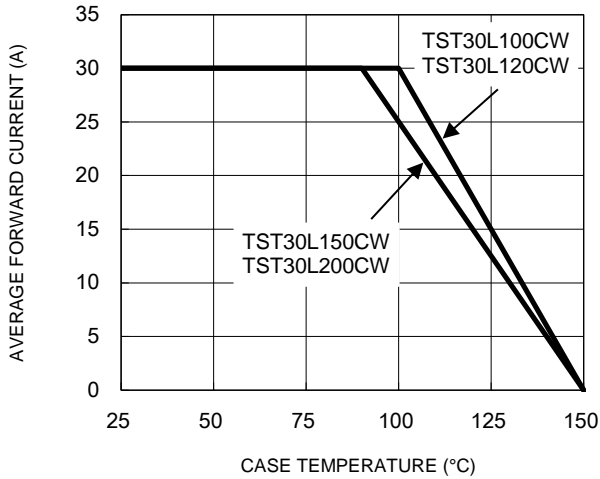
**Notes:**

1. "x" defines voltage from 100V(TST30L100CW) to 200V(TST30L200CW)

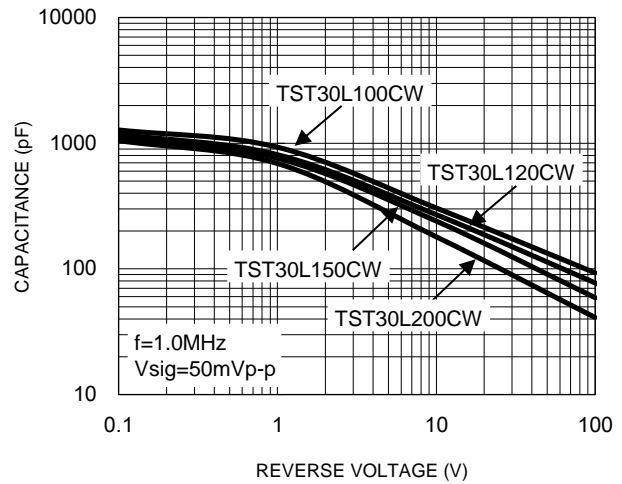
**CHARACTERISTICS CURVES**

( $T_A = 25^\circ\text{C}$  unless otherwise noted)

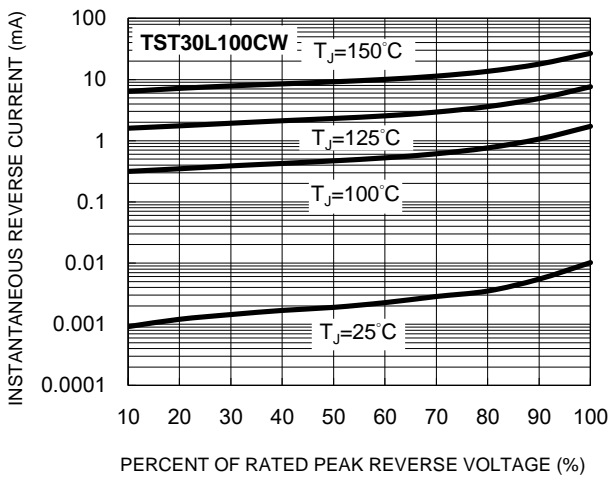
**Fig.1 Forward Current Derating Curve**



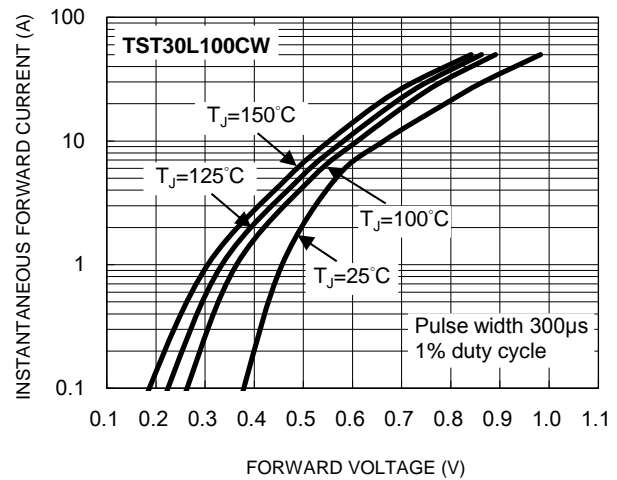
**Fig.2 Typical Junction Capacitance**



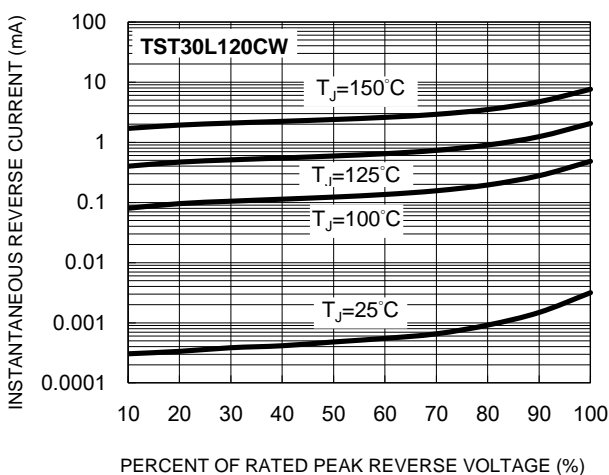
**Fig.3 Typical Reverse Characteristics**



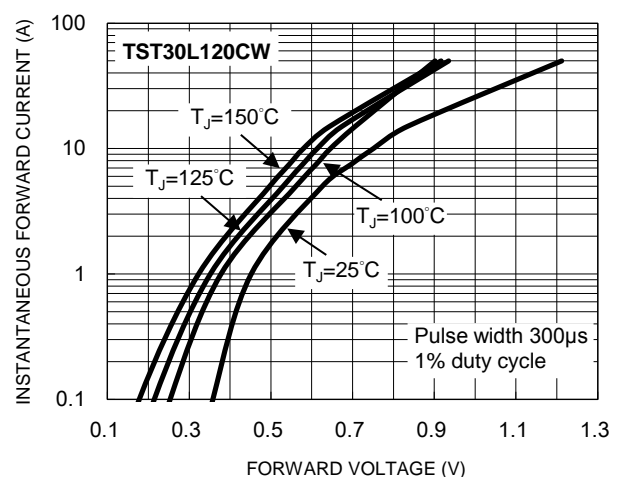
**Fig.4 Typical Forward Characteristics**



**Fig.5 Typical Reverse Characteristics**



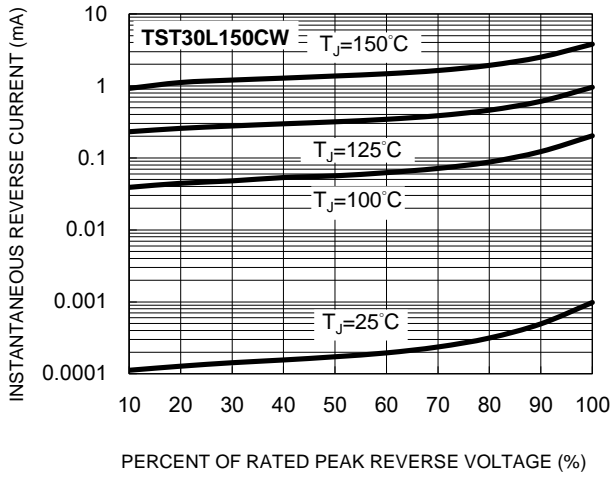
**Fig.6 Typical Forward Characteristics**



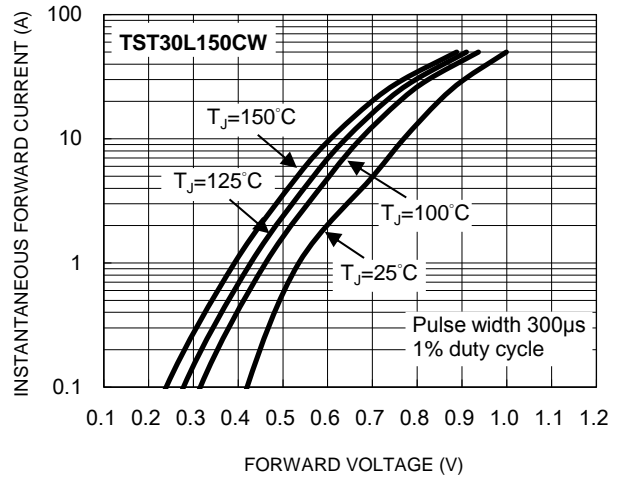
**CHARACTERISTICS CURVES**

( $T_A = 25^\circ\text{C}$  unless otherwise noted)

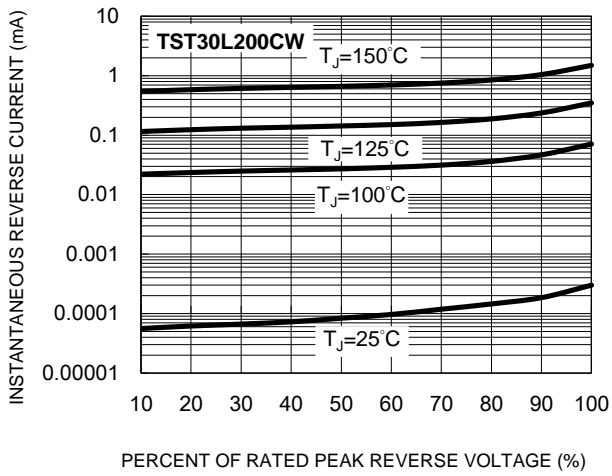
**Fig.7 Typical Reverse Characteristics**



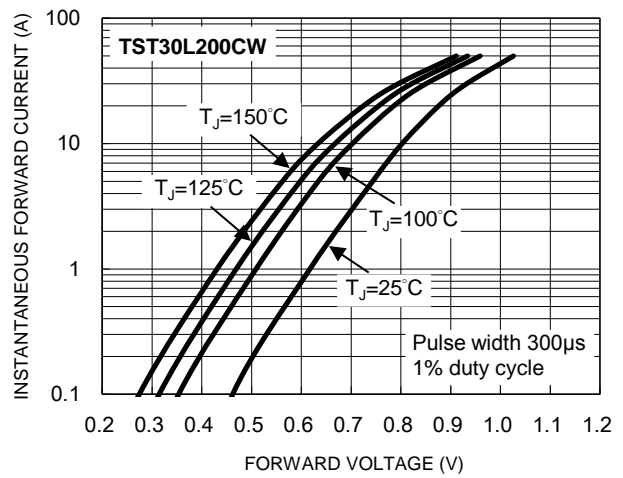
**Fig.8 Typical Forward Characteristics**



**Fig.9 Typical Reverse Characteristics**

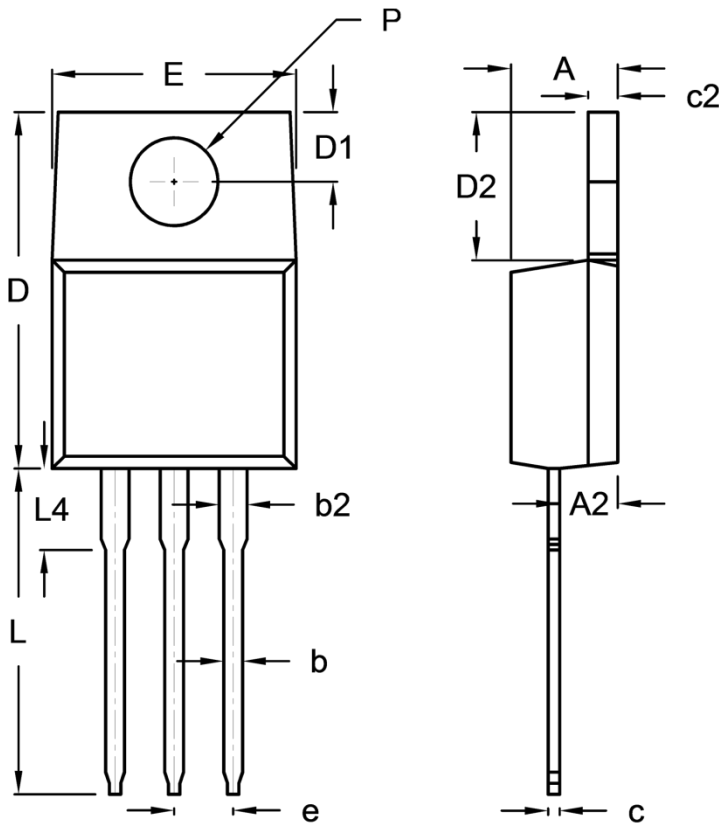


**Fig.10 Typical Forward Characteristics**



**PACKAGE OUTLINE DIMENSIONS**

TO-220AB



DIM.	Unit (mm)		Unit (inch)	
	Min.	Max.	Min.	Max.
A	4.42	4.76	0.174	0.187
A2	2.20	2.80	0.087	0.110
b	0.68	0.94	0.027	0.037
b2	0.95	1.45	0.037	0.057
c	0.35	0.64	0.014	0.025
c2	1.14	1.40	0.045	0.055
D	14.60	16.00	0.575	0.630
D1	2.54	3.44	0.100	0.135
D2	5.84	6.86	0.230	0.270
E	-	10.50	-	0.413
e	2.41	2.67	0.095	0.105
L	13.19	14.79	0.519	0.582
L4	2.80	4.20	0.110	0.165
P	3.54	4.00	0.139	0.157

**MARKING DIAGRAM**



- P/N = Marking Code
- G = Green Compound
- YWW = Date Code
- F = Factory Code