

TW8844, TW8845

LCD Video Processor with Built-In Decoder, LVDS and TTL Inputs, OSD, TCON, LVDS, and MIPI Interface

The [TW8844](#) and [TW8845](#) are highly integrated LCD video processors that incorporate many of the features required to create a multipurpose LCD display system. This includes a high quality 2D comb NTSC/PAL/SECAM video decoder that supports single-ended or differential composite video inputs, two independent TTL digital input interfaces (up to 24-bit each), two LVDS Open LDI input interfaces, two separate high-quality scaler and deinterlacer engines, as well as a versatile OSD and EEPROM interface. The outputs include dual channel LVDS Open LDI, or TTL panel interfaces, as well as a separate MIPI-CSI2 (TW8844) or pseudo BT.656 (TW8845) output. The TW8844 and TW8845 can support input resolutions up to 1080p and can drive LCD panels at resolutions up to 1920x1080. The TW8844 and TW8845's video processing capability includes arbitrary H/V scaling, panoramic scaling, image mirroring, image adjustment and enhancement, Automatic Contrast Adjustment (ACA), etc. In addition, the TW8844 and TW8845 have new image diagnostic capabilities to determine if the input video is corrupted. The feature set and versatility of this device makes it an ideal solution for automotive LCD display applications.

Applications

- Automotive display
- Industrial/military displays
- Portable/consumer displays

Related Literature

For a full list of related documents, visit our website:

- [TW8844](#) and [TW8845](#) device pages

Features

Analog Video Decoder

- Supports NTSC (M, 4.43) and PAL (B, D, G, H, I, M, N, N combination), PAL (60), SECAM with automatic format detection
- High quality adaptive 2D comb filter for both NTSC and PAL inputs
- 10-bit ADC and analog clamping circuit (clamping is 8-bit processing)
- Fully programmable static gain or automatic gain control for the CVBS channel
- Programmable white peak control for the CVBS channel
- Selectable single-ended or differential CVBS inputs
- PAL delay line for color phase error correction
- Image enhancement with 2D dynamic peaking/CTI
- Digital subcarrier PLL for accurate color decoding
- Programmable hue, brightness, saturation, contrast, sharpness
- Digital horizontal PLL and advanced synchronization processing for superior VCR playback and weak signal performance
- Up to 3CH differential or 6CH single-ended CVBS input

Digital Input Support

- Supports BT.656, 8-bit and 16-bit BT.601 and BT.1120 video formats
- Supports YCbCr/RGB 24-bit input up to 1080p resolution
- Two single channel LVDS open LDI inputs - up to 104MHz for each channel
- Dual channel LVDS open LDI input - up to 150MHz in Dual mode (75MHz per channel)
- Supports RGB565 + BT.656 at the same time

TFT Panel Support

- Built-in programmable timing controller
- Supports 3, 4, 6, or 8 bits per pixel up to 16.8 million colors with built-in dithering engine
- Supports single channel LVDS panels up to 1920x720 resolution (104MHz)
- Supports dual channel LVDS and digital panels (TTL) up to 1920x1080 resolution (150MHz)

Font Based On-Screen Display

- 4 windows font OSD with bordering/shadow
- 13,824 Bytes programmable font RAM and 1024 characters display RAM
- 1/2/3/4 bits per pixel
- Supports variable width (12/16), height (2~32)

SPI Flash Based On-Screen Display

- Supports fast register initialization by SPI-DMA
- 9 bitmap-based OSD windows in 2 layers through SPI with alpha blending between layers
- Supports 4/6/8 bits/pixel
- Supports RLE decompression for two windows
- Shares pins with EEPROM interface

EEPROM Interface

- EEPROM interface for fast boot register initialization
- Shares pins with SPI Flash memory interface

Image Processing

- Two high quality scalers with both up/down scaling support
- Built-in 2D deinterlacing function
- Supports programmable cropping of input video and graphics
- Automatic Contrast Adjustment (ACA) on 1 scaler path
- Independent RGB gain and offset controls
- 10-bit image enhancement processing and 10-bit Gamma correction

Clock Generation

- Spread spectrum PLL integrated to each scaler path
- Programmable modulation frequency and spread width

Timing Controller (TCON)

- Supports programmable interface signals for control
- Column (source) driver/Row (gate) driver

MIPI-CSI2 Output – TW8844 only

- 4 lane MIPI-CSI2 output port (1Gb/lane)
- Supports YUV422 and 24-bit RGB data formats

Pseudo BT.656 Output – TW8845 only

- Independent BT.656 compatible YCbCr(4:2:2) output format
- YCbCr(4:2:2) output generated from all input paths
- Output can be processed through the scaler path or bypass scaling all together

Miscellaneous

- Fast mode plus I²C interface up to 1.2Mbps with zero hold time
- Short diagnostics
 - Short to battery
 - Short to ground
- Up to 4 10-bit PWMs
- GPIOs
- Programmable drive strength for LVTTTL and LVDS
- Pin swapping (MSB ↔ LSB)
- Two separate input measurement engines with continuous measurement capability
- Smooth input switching via shadow registers
- 1.2V internal operation
- 1.8/3.3V I/O support
- Single 27MHz crystal
- 156 Ld LQFP with exposed thermal pad
- TW8844AT-LB1-GE and TW8845AT-LB1-GE are [AEC-Q100](#) qualified

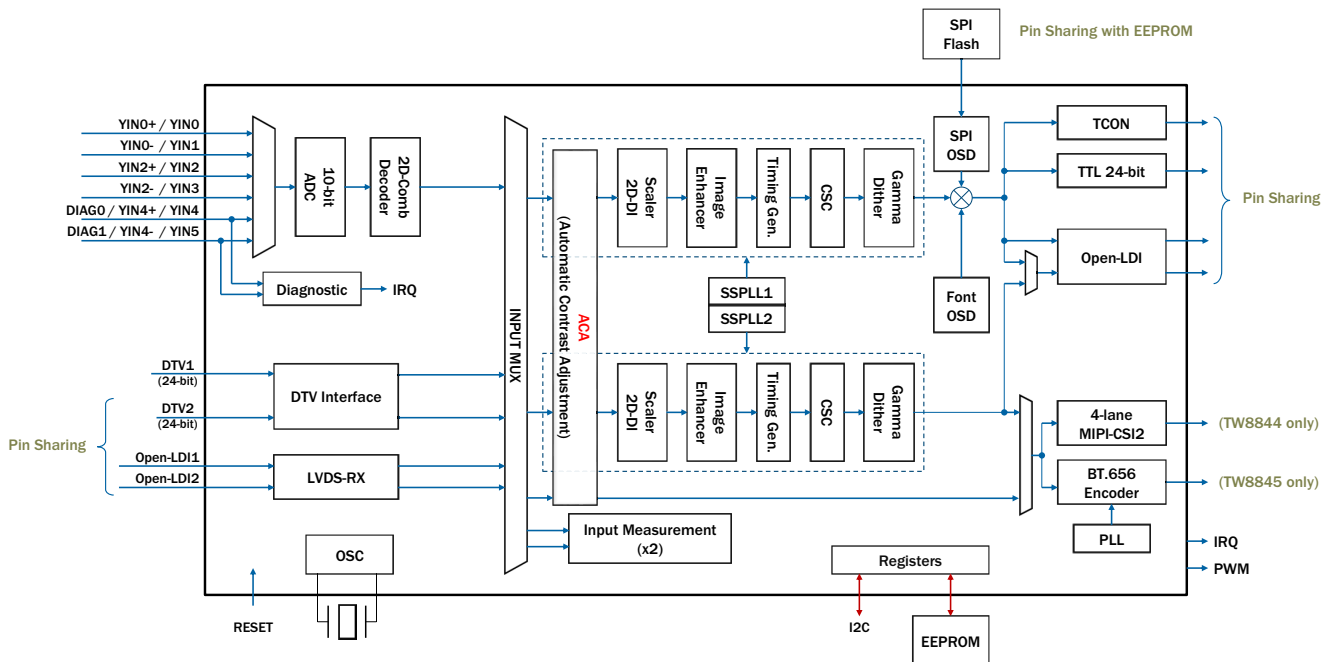

Figure 1. TW8844, TW8845 Functional Block Diagram