

TW8846, TW8847

R33DO0004EU0400

LCD Video Processor with Decoder, LVDS, TTL, MIPI, Image Enhancement, and Video Integrity Diagnostic

Rev.4.00

Sep 17, 2021

The [TW8846](#) and [TW8847](#) are highly integrated LCD video processors that incorporate many of the features required to create a multipurpose LCD display system. These features include a high quality 2D comb NTSC/PAL/SECAM video decoder that supports single-ended or differential composite video inputs, two independent TTL digital input interfaces (up to 24-bit each), two LVDS Open LDI input interfaces, two separate high quality scaler and de-interlacer engines, and a versatile OSD and an EEPROM/SPI interface. The outputs include dual channel LVDS Open LDI or TTL panel interfaces, and a separate MIPI-CSI2 output in the TW8846 and a pseudo BT.656 output in the TW8847. The TW8846 and TW8847 can support input resolutions up to 1080p and can drive LCD panels at resolutions up to 1920x1080. The video processing capabilities include 10-bit color processing, arbitrary H/V scaling, panoramic scaling, image mirroring, image adjustment and enhancement, black and white stretch, and automatic contrast adjustment. The TW8846 and TW8847 have improved image diagnostic capabilities to determine if the input video is corrupted. The feature set and versatility of this device makes it an ideal solution for automotive LCD display applications.

Applications

- Automotive display
- Industrial/military displays
- Portable/consumer displays

Features

Analog Video Decoder

- Supports NTSC (M, 4.43) and PAL (B, D, G, H, I, M, N, N combination), PAL (60), and SECAM with automatic format detection
- High quality adaptive 2D comb filter for both NTSC and PAL inputs
- 10-bit ADC and analog clamping circuit (clamping is 8-bit processing)
- Fully programmable static gain or automatic gain control for the CVBS channel
- Programmable white peak control for the CVBS channel
- Selectable single-ended or differential CVBS inputs
- PAL delay line for color phase error correction
- Image enhancement with 2D dynamic peaking/CTI
- Digital subcarrier PLL for accurate color decoding
- Programmable hue, brightness, saturation, contrast, and sharpness
- Digital horizontal PLL and advanced synchronization processing for superior VCR playback and weak signal performance
- Up to 3CH differential or 6CH single-ended CVBS input

Digital Input Support

- Supports BT.656, 8-bit and 16-bit BT.601, and BT.1120 video formats
- Supports YCbCr/RGB 24-bit input up to 1080p resolution
- Two single channel LVDS open LDI inputs, up to 104MHz for each channel
- Dual channel LVDS open LDI input, up to 150MHz in Dual mode (75MHz per channel)
- Supports RGB565 + BT.656 at the same time

TFT Panel Support

- Built-in programmable timing controller
- Supports 3, 4, 6, or 8 bits per pixel up to 16.8 million colors with built-in dithering engine
- Supports single channel LVDS panels up to 1920x720 resolution (104MHz)
- Supports dual channel LVDS and digital panels (TTL) up to 1920x1080 resolution (150MHz)

Font Based On-Screen Display

- Four windows font OSD with bordering/shadow
- 13824 bytes programmable font RAM and 1024 characters display RAM
- 1/2/3/4 bits per pixel
- Supports variable width (12/16), height (2~32)

SPI Flash Based On-Screen Display

- Supports fast register initialization by SPI-DMA
- Nine bitmap-based OSD windows in two layers through SPI with alpha blending between layers
- Supports 4/6/8 bits/pixel
- Supports RLE decompression for two windows
- Shares pins with EEPROM interface

EEPROM Interface

- EEPROM interface for fast boot register initialization
- Shares pins with SPI Flash memory interface

Image Processing

- Two high quality scalers with both up/down scaling support
- Built-in 2D de-interlacing function
- Supports programmable cropping of input video and graphics
- Automatic Contrast Adjustment (ACA) on one scaler path
- Independent RGB gain and offset controls
- 10-bit per color processing
- 10-bit image enhancement processing and 10-bit Gamma correction

Clock Generation

- Spread spectrum PLL integrated to each scaler path
- Programmable modulation frequency and spread width

Timing Controller (TCON)

- Supports programmable interface signals for control
- Column (source) driver/Row (gate) driver

MIPI-CSI2 Output (TW8846 only)

- Four lane MIPI-CSI2 output port (1Gb/lane)
- Supports YUV422 and 24-bit RGB data formats

Pseudo BT.656 Output (TW8847 only)

- Independent BT.656 compatible YCbCr (4:2:2) output format
- YCbCr (4:2:2) output generated from all input paths
- Output can be processed through the scaler path or bypass scaling all together

Miscellaneous

- Fast Mode plus I²C interface up to 1.2Mbps with zero hold time
- Short diagnostics
 - Short to battery
 - Short to ground
- Up to four 10-bit PWMs
- GPIOs
- Programmable drive strength for LVTTTL and LVDS
- Pin swapping (MSB ↔ LSB)
- Two separate input measurement engines with continuous measurement capability
- Smooth input switching using shadow registers
- 1.2V internal operation
- 1.8/3.3V I/O support
- Single 27MHz crystal
- 156 Ld LQFP with exposed thermal pad
- TW8846AT-LA1-GE and TW8847AT-LA1-GE are [AEC-Q100](#) qualified

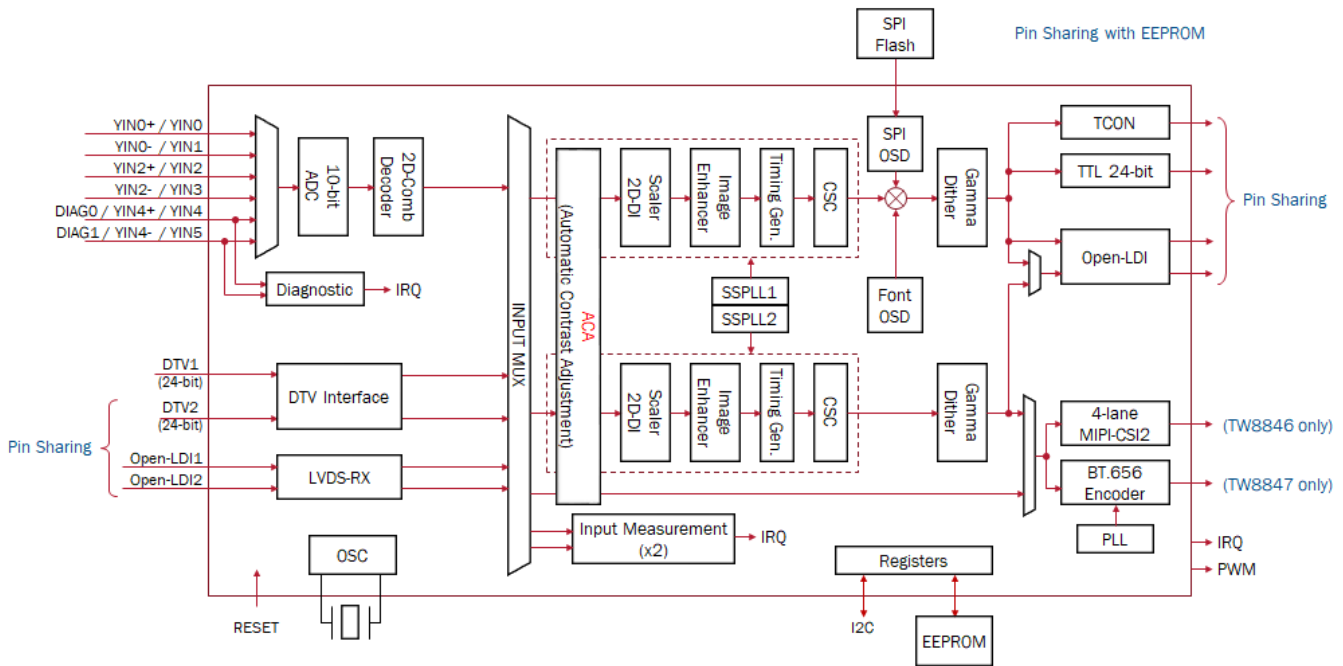

Figure 1. TW8846, TW8847 Functional Block Diagram

Notice

1. Descriptions of circuits, software and other related information in this document are provided only to illustrate the operation of semiconductor products and application examples. You are fully responsible for the incorporation or any other use of the circuits, software, and information in the design of your product or system. Renesas Electronics disclaims any and all liability for any losses and damages incurred by you or third parties arising from the use of these circuits, software, or information.
2. Renesas Electronics hereby expressly disclaims any warranties against and liability for infringement or any other claims involving patents, copyrights, or other intellectual property rights of third parties, by or arising from the use of Renesas Electronics products or technical information described in this document, including but not limited to, the product data, drawings, charts, programs, algorithms, and application examples.
3. No license, express, implied or otherwise, is granted hereby under any patents, copyrights or other intellectual property rights of Renesas Electronics or others.
4. You shall be responsible for determining what licenses are required from any third parties, and obtaining such licenses for the lawful import, export, manufacture, sales, utilization, distribution or other disposal of any products incorporating Renesas Electronics products, if required.
5. You shall not alter, modify, copy, or reverse engineer any Renesas Electronics product, whether in whole or in part. Renesas Electronics disclaims any and all liability for any losses or damages incurred by you or third parties arising from such alteration, modification, copying or reverse engineering.
6. Renesas Electronics products are classified according to the following two quality grades: "Standard" and "High Quality". The intended applications for each Renesas Electronics product depends on the product's quality grade, as indicated below.

"Standard": Computers; office equipment; communications equipment; test and measurement equipment; audio and visual equipment; home electronic appliances; machine tools; personal electronic equipment; industrial robots; etc.

"High Quality": Transportation equipment (automobiles, trains, ships, etc.); traffic control (traffic lights); large-scale communication equipment; key financial terminal systems; safety control equipment; etc.

Unless expressly designated as a high reliability product or a product for harsh environments in a Renesas Electronics data sheet or other Renesas Electronics document, Renesas Electronics products are not intended or authorized for use in products or systems that may pose a direct threat to human life or bodily injury (artificial life support devices or systems; surgical implantations; etc.), or may cause serious property damage (space system; undersea repeaters; nuclear power control systems; aircraft control systems; key plant systems; military equipment; etc.). Renesas Electronics disclaims any and all liability for any damages or losses incurred by you or any third parties arising from the use of any Renesas Electronics product that is inconsistent with any Renesas Electronics data sheet, user's manual or other Renesas Electronics document.

7. No semiconductor product is absolutely secure. Notwithstanding any security measures or features that may be implemented in Renesas Electronics hardware or software products, Renesas Electronics shall have absolutely no liability arising out of any vulnerability or security breach, including but not limited to any unauthorized access to or use of a Renesas Electronics product or a system that uses a Renesas Electronics product. RENESAS ELECTRONICS DOES NOT WARRANT OR GUARANTEE THAT RENESAS ELECTRONICS PRODUCTS, OR ANY SYSTEMS CREATED USING RENESAS ELECTRONICS PRODUCTS WILL BE INVULNERABLE OR FREE FROM CORRUPTION, ATTACK, VIRUSES, INTERFERENCE, HACKING, DATA LOSS OR THEFT, OR OTHER SECURITY INTRUSION ("Vulnerability Issues"). RENESAS ELECTRONICS DISCLAIMS ANY AND ALL RESPONSIBILITY OR LIABILITY ARISING FROM OR RELATED TO ANY VULNERABILITY ISSUES. FURTHERMORE, TO THE EXTENT PERMITTED BY APPLICABLE LAW, RENESAS ELECTRONICS DISCLAIMS ANY AND ALL WARRANTIES, EXPRESS OR IMPLIED, WITH RESPECT TO THIS DOCUMENT AND ANY RELATED OR ACCOMPANYING SOFTWARE OR HARDWARE, INCLUDING BUT NOT LIMITED TO THE IMPLIED WARRANTIES OF MERCHANTABILITY, OR FITNESS FOR A PARTICULAR PURPOSE.
8. When using Renesas Electronics products, refer to the latest product information (data sheets, user's manuals, application notes, "General Notes for Handling and Using Semiconductor Devices" in the reliability handbook, etc.), and ensure that usage conditions are within the ranges specified by Renesas Electronics with respect to maximum ratings, operating power supply voltage range, heat dissipation characteristics, installation, etc. Renesas Electronics disclaims any and all liability for any malfunctions, failure or accident arising out of the use of Renesas Electronics products outside of such specified ranges.