

TWR-SMPS-LVFB User's Guide

1 Overview

The Low-Voltage Full-Bridge DC-DC Switch Mode Power Supply Tower board (TWR-SMPS-LVFB) is a peripheral Tower System Module used as a development platform that enables rapid prototyping of various power-control topologies using Freescale MCUs. A variety of power-control topologies such as peak current mode control, average current mode control and voltage mode control can be implemented using the MC56Fx TWR-MC56F8xxx and KVx TWR-KVx MCU Tower System MCU / peripheral board. The dynamic load circuit module is also included in the system to test the performance of power-control topologies and demo software, by connecting a load resistor at the output.

The TWR-SMPS-LVFB module features:

- 20 – 30 VDC power supply voltage input (see [Section 3.2, “Electrical characteristics”](#) for details)
- Output current up to 8 A
- Power supply reverse polarity protection circuitry
- Full-bridge topology
- Synchronous rectification for secondary side

Contents

1. Overview	1
2. Reference documents	3
3. Hardware features	3
4. Hardware connection description	7
5. Mechanical form factor	14
6. Revision history	14

Overview

- Primary side full-bridge current sensing
- Input DC-bus voltage sensing
- Output voltage sensing
- Low-voltage on-board power supplies
- Two user LEDs, power-on LED and six PWM LED diodes

A block diagram for the TWR-SMPS-LVFB is shown in [Figure 1](#).

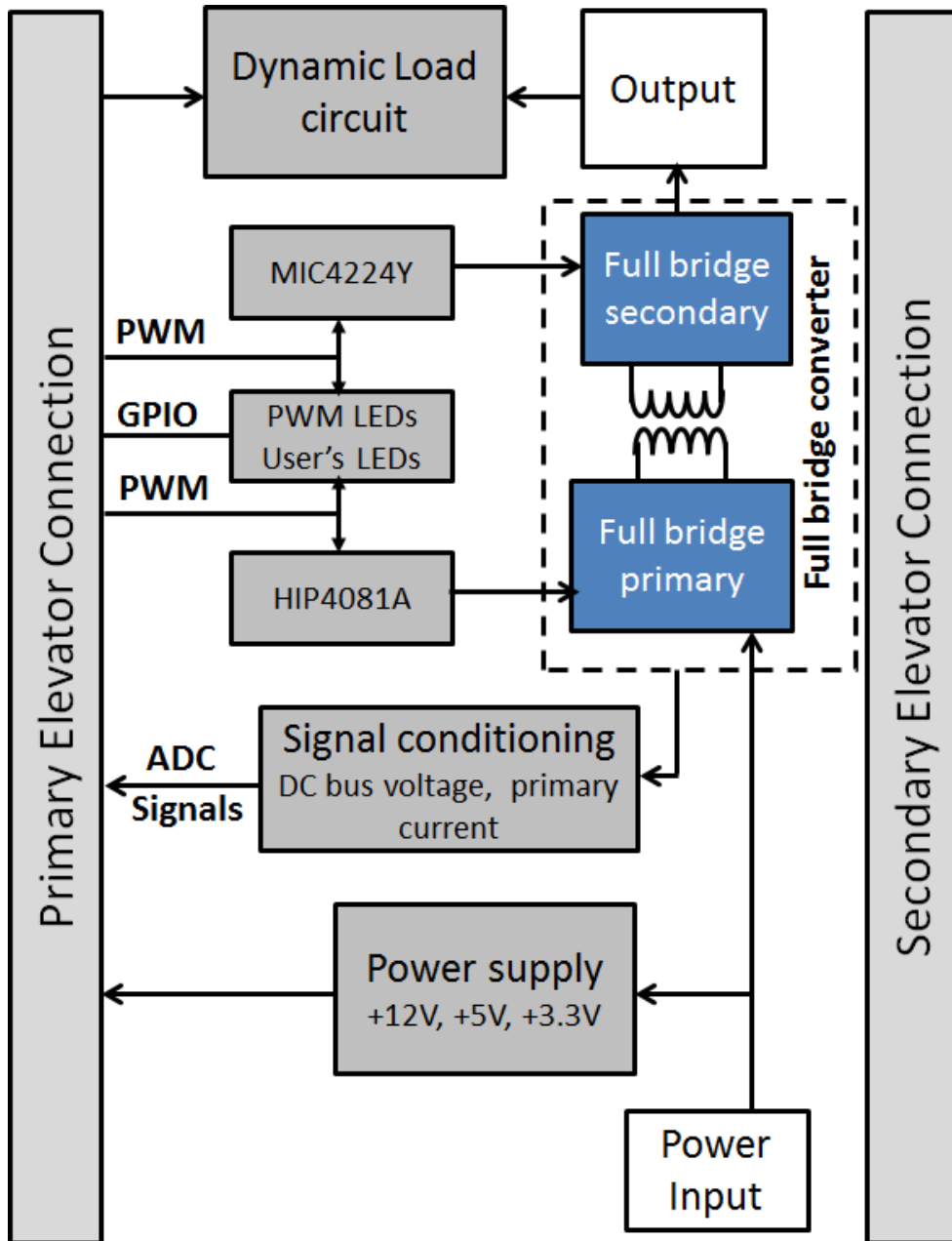

Figure 1. TWR-SMPS-LVFB block diagram

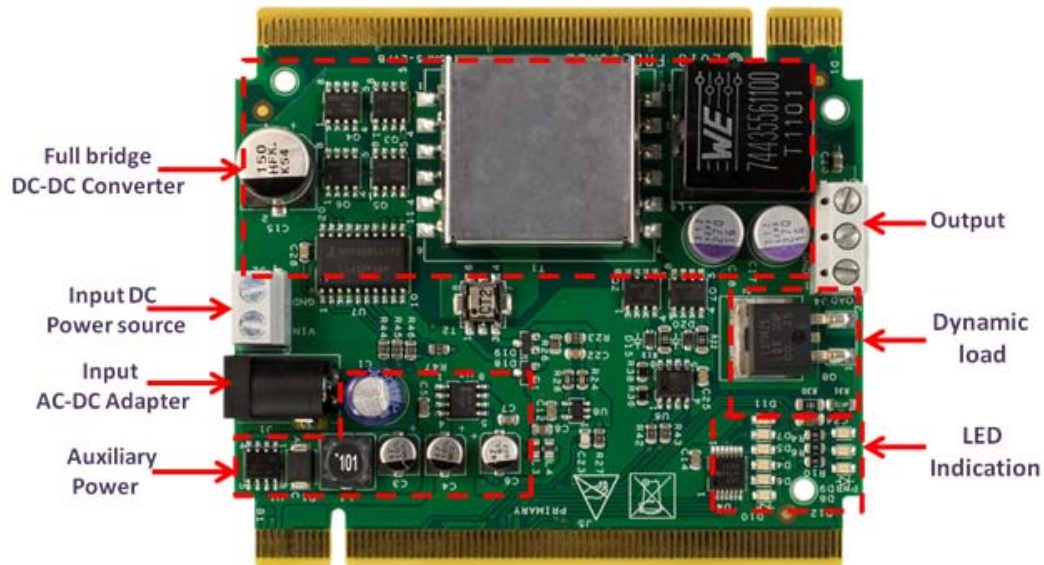

Figure 2. TWR-SMPS-LVFB component placement

2 Reference documents

The documents listed below may be referenced for more information on the Freescale Tower System and the TWR-SMPS- LVFB board:

- *TWR-SMPS-LVFB Schematics*
- *TWR-SMPS-LVFB Quick Start Guide*
- *Controller (56Fxxx/KV4xxx) TWR card Quick Start Guide*
- *Freescale embedded system library FSLESL*

Refer to freescale.com/tower for the latest versions of the Freescale Tower System documentation.

3 Hardware features

This section provides details about the hardware features and functionality of the TWR-SMPS-LVFB board.

3.1 Power supply

Freescale's TWR-SMPS-LVFB Tower board operates on DC input voltages of 20 – 30 V. The TWR-SMPS-LVFB is intended to be powered from an external AC-DC power supply of 24 V, 3 A output or DC power source which can provide 20 – 30 V output. All the needed auxiliary voltages for digital, analog and MOSFET drivers are derived from the input voltage. The module includes 12 V, 5 V and 3.3 V power supplies. The 12 V power supply is used to provide power to the PWM drivers, whereas the 5 V and 3 V power supplies are capable of providing power to the entire Tower System development board platform.

3.1.1 12 V power supply

The 12 V voltage is generated using the LM2594HVM switching step-down regulator. The input to the LM2594 is taken from the input voltage of the TWR-SMPS-LVFB board; it ranges from 20 to 30 V. This regulator can supply up to 500 mA. The 12 V power rail is used to supply power to the MC33269, full-bridge MOSFET driver (HIP4081AIBZ) and synchronous MOSFET driver (MIC4224YM).

3.1.2 5 V power supply

The 5 V voltage is generated from the linear regulator MC33269D, input to the MC33269D is taken from the 12 V supply. This converter can supply up to 800 mA. The linear regulator is used for simplicity of the board design.

3.1.3 3.3 V power supply

The 3.3 V voltage is generated from the MC33269D linear voltage regulator and can supply up to 800 mA. The 3.3 V power rail is important as it is used for both analog and digital circuits. This power rail is also used to lit LEDs. The linear regulator is used for simplicity of the board design.

3.1.4 Analog power supply and grounding

The separated 3.3 V analog voltage and the ground plane are used to sense analog quantities (currents and voltages). This voltage level is generated from the 3.3 V digital power supply using the LC filter. The LC filter is used to derive analog to clean the power rail from digital noise.

3.2 Electrical characteristics

The electrical characteristics listed in [Table 1](#) apply to operation at 25°C with 24 VDC power-supply voltage. The maximal input voltage cannot be higher than 30 V. Only 30 V maximal input voltage is allowed.

CAUTION

If an input voltage higher than 30 V is applied, the plugged-in Tower modules might be damaged.

Table 1. Electrical characteristics

Characteristics	Symbol	Min.	Typ.	Max.	Units
DC input voltage	V _{in}	20	24	30	V
Quiescent current	I _{cc}	–	220	–	mA
Output voltage range	V _o	–	5	–	V
Continuous output current	I _o	0	–	8	A
Current sense voltage	I_IN_SENSE	–	730	–	mV / A
Output voltage sense voltage	VO_SENSE	–	500	–	mV / V
Output voltage sense voltage	VIN_SENSE	–	100	–	mV / V

Table 1. Electrical characteristics (continued)

Characteristics	Symbol	Min.	Typ.	Max.	Units
Power dissipation per MOSFET	P_{DD}	–	–	300	mW
Dead time (set by software)	t_{off}	–	–	0.669	μ s
Dynamic load circuit rise time (2 to 6 A load current)	t_r	–	600	–	μ s
Dynamic load circuit fall time (6 to 2 A load current)	t_f	–	600	–	μ s

3.3 Full-bridge DC-DC converter

The full-bridge DC-DC converter is a transformer-isolated buck converter. The full-bridge topology contains full-bridge inverter block, transformer, synchronous rectification block, and filter, as shown in Figure 3. The full-bridge inverter block converts the DC input into high frequency AC (frequency used in this design is 150 KHz). The transformer brings the high-frequency AC voltage in level with the output voltage. The secondary side high-frequency AC is rectified to DC through the synchronous rectification. Finally, the LC filter reduces the ripples in the DC voltage to get a final stable DC output. The output voltage is 5 V and it can deliver up to 8 A of load current. Input voltage range is 20 – 30 V DC.

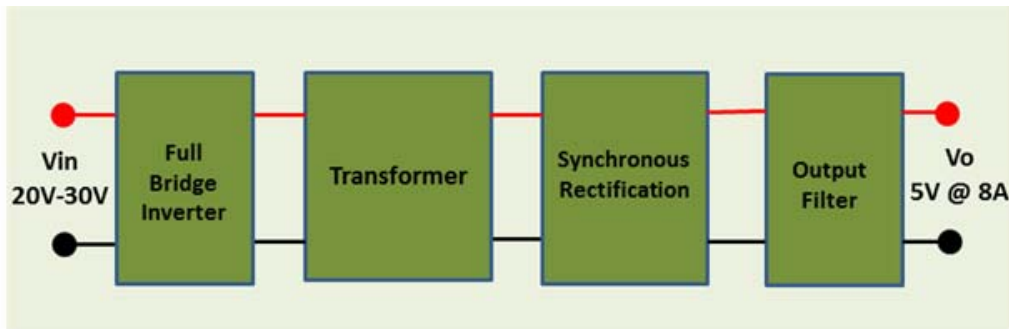
Figure 3. Full-bridge DC-DC converter topology block diagram

3.4 Feedback circuits

The feedback circuits scale down the high voltage / current to a safe low voltage and amplify the low voltage to a voltage permissible for the MCU to sense the power circuit physical quantity. The resistor divider network is used for the voltage feedback and current transformer with the load resistor is used for current feedback.

3.4.1 Output voltage feedback

The output voltage is scaled down by a resistor divider consisting of R33 and R35. The values are chosen in such a way that a 6.6 V output voltage corresponds to 3.3 V at the VO_SENSE output. The VO_SENSE is scaled at 500 mV per volt of the DC output voltage and is terminated on the main primary elevator port.

$$VO_SENSE = V_o \times (R35 / (R33 + R35))$$

where:

- V_o is the output voltage
- VO_SENSE is the corresponding output voltage at the ADC

3.4.2 Input voltage feedback

The input voltage is scaled down by a voltage divider consisting of R32 and R34. The values are chosen in such a way that a 33 V input voltage corresponds to 3.3 V at the VIN_SENSE output. The VIN_SENSE is scaled at 100 mV per volt of the DC input voltage and is terminated on the main primary elevator port.

$$VIN_SENSE = V_{in} \times (R34 / (R32 + R34))$$

where:

- V_{in} is the input voltage
- VIN_SENSE is the corresponding input voltage at the ADC

3.4.3 Full-bridge primary current feedback

The primary current of the full-bridge transformer is converted to scaled voltage by the current transformer (CT) followed by a diode rectifier and a load resistor. The voltage across the load resistor is amplified to get a full resolution of the ADC. The values of the current-sense circuit are chosen in such a way that a 4.5 A instantaneous current corresponds to 3.3 V at the I_IN_SENSE output. The I_IN_SENSE is scaled at 730 mV per 1 A of the primary current and is terminated on the main primary elevator port.

$$I_IN_SENSE = (I_{primary} \times R26 \times (R29 / R28)) / N$$

3.5 Dynamic load circuit

The dynamic load circuit contains a MOSFET and a user control gate driver circuitry to control the external load (resistor). The dynamic load circuit MOSFET connects the external power resistor to the output. The slew rate of the dynamic load and the ON and OFF time is controlled by controlling the gate drive pulse width of the MOSFET. The gate drive of the MOSFET is controlled by the controller (56Fxxx / KVxxxx) using PWM. The PWM of the gate drive is chosen in such a way that the dynamic load MOSFET can have controlled transition from resistive to active region. The slew rate of the output load is controlled by controlling the MOSFET transition time from the resistive to the active region. The ON and OFF time is controlled by keeping the MOSFET in active and inactive regions. The maximum slew rate is limited by the RC (that is $t_c = R30 \times C24$) time constant of the resistor and capacitor used at the gate of dynamic load MOSFET.

3.6 LED indication

This module also contains nine LED indicators. For more details on the LED position and its level please refer to the TWR-SMPS-LVFB schematic.

Table 2. LED indication

LED	Description
D4	PWM_HSA indication LED
D5	PWM_LSB indication LED
D6	PWM_LSA indication LED
D7	PWM_SYNCA indication LED
D8	Fault indicator (input under-voltage)
D9	Fault indicator (input over-voltage)
D10	PWM_HSB indication LED
D11	PWM_SYNCB indication LED
D12	Indicates that the +3.3 V level is properly generated

4 Hardware connection description

This section provides more details about signals of input / output connectors and Tower-elevator connections of the TWR- SMPS-LVFB board.

4.1 Adapter input connector J1

If the AC-DC power supply adapter is used as input source, it is connected to the J1 connector. A 24 V, 3 A, AC-DC adapter is used as the input source.

4.2 Power supply input connector J2

If a DC power supply is used as the input source it is connected to the J2 connector with the positive terminal of the power supply being connected to pin 2 and ground connected to pin 1. The input voltage range is 20 – 30 VDC. The connectors J1 and J2 are both parallel, hence make sure that only one input source is used at a given time.

4.3 Load connector J4

The J4 is a three-pin connector. For application demonstration purposes, two power resistors (2.5 Ω and 1.2 Ω) are used as a load. The power resistor for continuous load is connected across pins 3 and 2, and for dynamic load, it is connected across pins 3 and 1. The value of the power resistor is chosen in such a way that the total current drawn from the 5 V DC output should not be higher than 8 A.

In case an electronic load is used, it should be connected across pins 3 and 2 with positive terminal at pin 3 and ground at pin 2.

4.4 Elevator connections

The TWR-SMPS-LVFB board features two expansion-card edge connectors that interface to the elevator boards in the Tower system: the primary and secondary elevator connectors. [Table 3](#) and [Table 4](#) provide the pinouts for the primary and secondary elevator connectors respectively. An “X” in the “Used” column indicates that there is a connection from the TWR-SMPS-LVFB to that pin on the elevator connector.

Table 3. TWR-SMPS-LVFB primary elevator connector pinout

Pin	Name	Usage	Used	Pin	Name	Usage	Used
B1	5V	5 V Power	X	A1	5V	5 V Power	X
B2	GND	Ground	X	A2	GND	Ground	X
B3	3.3V	3.3 V Power	X	A3	3.3V	3.3 V Power	X
B4	ELE_PS_SENSE	Elevator Power Sense	X	A4	3.3V	3.3 V Power	X
B5	GND	Ground	X	A5	GND	Ground	X
B6	GND	Ground	X	A6	GND	Ground	X
B7	SDHC_CLK / SPI1_CLK	–		A7	SCL0	–	
B8	SDHC_D3 / SPI1_CS1_b	–		A8	SDA0	–	
B9	SDHC_D3 / SPI1_CS0_b	–		A9	GPIO9 / CTS1	–	
B10	SDHC_CMD / SPI1_MOSI	–		A10	GPIO8 / SDHC_D2	–	
B11	SDHC_D0 / SPI1_MISO	–		A11	GPIO7 / SD_WP_DET	–	
B12	ETH_COL	–		A12	ETH_CRS	–	
B13	ETH_RXER	–		A13	ETH_MDC	–	
B14	ETH_TXCLK	–		A14	ETH_MDIO	–	
B15	ETH_TXEN	–		A15	ETH_RXCLK	–	
B16	ETH_TXER	–		A16	ETH_RXDV	–	
B17	ETH_TXD3	–		A17	ETH_RXD3	–	
B18	ETH_TXD2	–		A18	ETH_RXD2	–	
B19	ETH_TXD1	–		A19	ETH_RXD1	–	
B20	ETH_TXD0	–		A20	ETH_RXD0	–	
B21	GPIO1 / RTS1	–		A21	SSI_MCLK	–	
B22	GPIO2 / SDHC_D1	–		A22	SSI_BCLK	–	
B23	GPIO3	–		A23	SSI_FS	–	
B24	CLKIN0	–		A24	SSI_RXD	–	

Table 3. TWR-SMPS-LVFB primary elevator connector pinout (continued)

Pin	Name	Usage	Used	Pin	Name	Usage	Used
B25	CLKOUT1	–		A25	SSI_TXD	–	
B26	GND	Ground	X	A26	GND	Ground	X
B27	AN7	–		A27	AN3	–	
B28	AN6	–		A28	AN2	–	
B29	AN5	–		A29	AN1	VIN_SENSE	X
B30	AN4	–		A30	AN0	I_IN_SENSE	X
B31	GND	–		A31	GND	Ground	X
B32	DAC1	–		A32	GPIOC5	OV_MCU	X
B33	TMR3	–		A33	TMR1	UV_MCU	X
B34	TMR2	–		A34	TMR0	–	
B35	ANB7	VO_SENSE	X	A35	GPIO6	–	
B36	3.3V	–		A36	3.3V	3.3 V Power	X
B37	PWM7	–		A37	PWM3	PWM_LSB	X
B38	PWM6	LOAD_CTRL	X	A38	PWM2	PWM_LSA	X
B39	PWM5	PWM_SYNCA	X	A39	PWM1	PWM_HSB	X
B40	PWM4	PWM_SYNCB	X	A40	PWM0	PWM_HSA	X
B41	CANRX0	–		A41	RXD0	–	
B42	CANTX0	–		A42	TXD0	–	
B43	1WIRE	–		A43	RXD1	–	
B44	SPI0_MISO (IO1)	–		A44	TXD1	–	
B45	SPI0_MOSI (IO0)	–		A45	VSS	AGND	X
B46	SPI0_CS0_b	–		A46	VDDA	VDDA_3V3	X
B47	SPI0_CS1_b	–		A47	VREFA1	–	
B48	SPI0_CLK	–		A48	VREFA2	–	
B49	GND	Ground	X	A49	GND	Ground	X
B50	SCL1	–		A50	GPIO14	–	
B51	SDA1	–		A51	GPIO15	–	
B52	GPIO5 / SPI0_HOLD (IO3)	–		A52	GPIO16 / SPI0_WP (IO2)	–	
B53	USB0_DP_PDOWN	–		A53	GPIO17	–	
B54	USB0_DM_PDOWN	–		A54	USB0_DM	–	
B55	IRQ_H	–		A55	USB0_DP	–	
B56	IRQ_G	–		A56	USB0_ID	–	

Table 3. TWR-SMPS-LVFB primary elevator connector pinout (continued)

Pin	Name	Usage	Used	Pin	Name	Usage	Used
B57	IRQ_F	–		A57	USB0_VBUS	–	
B58	IRQ_E	–		A58	TMR7	–	
B59	IRQ_D	–		A59	TMR6	–	
B60	IRQ_C	–		A60	TMR5	–	
B61	IRQ_B	–		A61	TMR4	–	
B62	IRQ_A	–		A62	RSTIN_b	–	
B63	EBI_ALE / EBI_CS1_b	–		A63	RSTOUT_b	–	
B64	EBI_CS0_b	–		A64	CLKOUT0	–	
B65	GND	Ground	X	A65	GND	Ground	X
B66	EBI_AD15	–		A66	EBI_AD14	–	
B67	EBI_AD16	–		A67	EBI_AD13	–	
B68	EBI_AD17	–		A68	EBI_AD12	–	
B69	EBI_AD18	–		A69	EBI_AD11	–	
B70	EBI_AD19	–		A70	EBI_AD10	–	
B71	EBI_R/W_b	–		A71	EBI_AD9	–	
B72	EBI_OE_b	–		A72	EBI_AD8	–	
B73	EBI_D7	–		A73	EBI_AD7	–	
B74	EBI_D6	–		A74	EBI_AD6	–	
B75	EBI_D5	–		A75	EBI_AD5	–	
B76	EBI_D4	–		A76	EBI_AD4	–	
B77	EBI_D3	–		A77	EBI_AD3	–	
B78	EBI_D2	–		A78	EBI_AD2	–	
B79	EBI_D1	–		A79	EBI_AD1	–	
B80	EBI_D0	–		A80	EBI_AD0	–	
B81	GND	Ground	X	A81	GND	Ground	X
B82	3.3V	3.3 V Power	X	A82	3.3V	3.3 V Power	X

Table 4. TWR-SMPS-LVFB Secondary Elevator connector pinout

Pin	Name	Usage	Used	Pin	Name	Usage	Used
D1	5V	–		C1	5V	–	
D2	GND	Ground	X	C2	GND	Ground	
D3	3.3V	–		C3	3.3V	–	
D4	ELE_PS_SENSE	–		C4	3.3V	–	
D5	GND	Ground	X	C5	GND	Ground	
D6	GND	Ground	X	C6	GND	Ground	
D7	SPI2_CLK	–		C7	SCL2	–	
D8	SPI2_CS1_b	–		C8	SDA2	–	
D9	SPI2_CS0_b	–		C9	GPIO25	–	
D10	SPI2_MOSI	–		C10	ULPI_STOP	–	
D11	SPI2_MISO	–		C11	ULPI_CLK	–	
D12	ETH_COL	–		C12	GPIO26	–	
D13	ETH_RXER	–		C13	ETH_MDC	–	
D14	ETH_TXCLK	–		C14	ETH_MDIO	–	
D15	ETH_TXEN	–		C15	ETH_RXCLK	–	
D16	GPIO18	–		C16	ETH_RXDV	–	
D17	GPIO19 / SDHC_D4	–		C17	GPIO27 / SDHC_D6	–	
D18	GPIO20 / SDHC_D5	–		C18	GPIO28 / SDHC_D7	–	
D19	ETH_TXD1	–		C19	ETH_RXD1	–	
D20	ETH_TXD0	–		C20	ETH_RXD0	–	
D21	ULPI_NEXT / USB1_DM	–		C21	ULPI_DATA0 / USB3_DM	–	
D22	ULPI_DIR / USB1_DP	–		C22	ULPI_DATA1 / USB3_DP	–	
D23	ULPI_DATA5 / USB2_DM	–		C23	ULPI_DATA2 / USB4_DM	–	
D24	ULPI_DATA6 / USB2_DP	–		C24	ULPI_DATA3 / USB4_DP	–	
D25	ULPI_DATA7	–		C25	ULPI_DATA4	–	
D26	GND	Ground	X	C26	GND	Ground	
D27	LCD_HSYNC / LCD_P24	–		C27	AN11	–	
D28	LCD_VSYNC / LCD_P25	–		C28	AN10	–	

Table 4. TWR-SMPS-LVFB Secondary Elevator connector pinout (continued)

Pin	Name	Usage	Used	Pin	Name	Usage	Used
D29	AN3	–		C29	AN9	–	
D30	AN12	–		C30	AN8	–	
D31	GND	Ground	X	C31	GND	Ground	X
D32	LCD_CLK / LCD_P26	–		C32	GPIO29	–	
D33	TMR11	–		C33	TMR9	–	
D34	TMR10	–		C34	TMR8	–	
D35	GPIO21	–		C35	GPIO30	–	
D36	3.3V	–		C36	3.3V	–	
D37	PWM15	–		C37	PWM11	–	
D38	PWM14	–		C38	PWM10	–	
D39	PWM13	–		C39	PWM9	–	
D40	PWM12	–		C40	PWM8	–	
D41	CANRX1	–		C41	RXD2 / TSI0	–	
D42	CANTX1	–		C42	TXD2 / TSI1	–	
D43	GPIO22	–		C43	RTS2 / TSI2	–	
D44	LCD_OE / LCD_P27	–		C44	CTS2 / TSI3	–	
D45	LCD_D0 / LCD_P0	–		C45	RXD3 / TSI4	–	
D46	LCD_D1 / LCD_P1	–		C46	TXD3 / TSI5	–	
D47	LCD_D2 / LCD_P2	–		C47	RTS3 / TSI6	–	
D48	LCD_D3 / LCD_P3	–		C48	CTS3 / TSI7	–	
D49	GND	Ground		C49	GND	Ground	
D50	GPIO23	–		C50	LCD_D4 / LCD_P4	–	
D51	GPIO24	–		C51	LCD_D5 / LCD_P5	–	
D52	LCD_D12 / LCD_P12	–		C52	LCD_D6 / LCD_P6	–	
D53	LCD_D13 / LCD_P13	–		C53	LCD_D7 / LCD_P7	–	
D54	LCD_D13 / LCD_P13	–		C54	LCD_D8 / LCD_P8	–	
D55	IRQ_P / SPI2_CS2_b	–		C55	LCD_D9 / LCD_P9	–	
D56	IRQ_O / SPI2_CS3_b	–		C56	LCD_D10 / LCD_P10	–	

Table 4. TWR-SMPS-LVFB Secondary Elevator connector pinout (continued)

Pin	Name	Usage	Used	Pin	Name	Usage	Used
D57	IRQ_N	–		C57	LCD_D11 / LCD_P11	–	
D58	IIRQ_M	–		C58	TMR16	–	
D59	IRQ_L	–		C59	TMR15	–	
D60	IRQ_K	–		C60	TMR14	–	
D61	IRQ_J	–		C61	TMR13	–	
D62	IRQ_I	–		C62	LCD_D15 / LCD_P15	–	
D63	LCD_D18 / LCD_P18	–		C63	LCD_D16 / LCD_P16	–	
D64	LCD_D19 / LCD_P19	–		C64	LCD_D17 / LCD_P17	–	
D65	GND	Ground		C65	GND	Ground	X
D66	EBI_AD20 / LCD_P42	–		C66	EBI_BE_32_24_b / LCD_P28	–	
D67	EBI_AD21 / LCD_P43	–		C67	EBI_BE_23_16_b / LCD_P29	–	
D68	EBI_AD22 / LCD_P44	–		C68	EBI_BE_15_8_b / LCD_P30	–	
D69	EBI_AD23 / LCD_P45	–		C69	EBI_BE_7_0_b / LCD_P31	–	
D70	EBI_AD24 / LCD_P46	–		C70	EBI_TSIZE0 / LCD_P32	–	
D71	EBI_AD25 / LCD_P47	–		C71	EBI_TSIZE1 / LCD_P33	–	
D72	EBI_AD26 / LCD_P48	–		C72	EBI_TS_b / LCD_P34	–	
D73	EBI_AD27 / LCD_P49	–		C73	EBI_TBST_b / LCD_P35	–	
D74	EBI_AD28 / LCD_P50	–		C74	EBI_TA_b / LCD_P36	–	
D75	EBI_AD29 / LCD_P51	–		C75	EBI_CS4_b / LCD_P37	–	
D76	EBI_AD30 / LCD_P52	–		C76	EBI_CS3_b / LCD_P38	–	
D77	EBI_AD31 / LCD_P53	–		C77	EBI_CS2_b / LCD_P39	–	
D78	LCD_D20 / LCD_P20	–		C78	E EBI_CS1_b / LCD_P40BI_AD2	–	
D79	LCD_D21 / LCD_P21	–		C79	GPIO31 / LCD_P41	–	

Table 4. TWR-SMPS-LVFB Secondary Elevator connector pinout (continued)

Pin	Name	Usage	Used	Pin	Name	Usage	Used
D80	LCD_D22 / LCD_P22	–		C80	LCD_D23 / LCD_P23	–	
D81	GND	Ground	X	C81	GND	Ground	X
D82	3.3V	–		C82	3.3V	–	

5 Mechanical form factor

The TWR-SMPS-LVFB board is designed for the Freescale Tower System development board platform as a side-mounting peripheral and complies with the electrical and mechanical specification as described in *Freescale Tower Electromechanical Specification*.

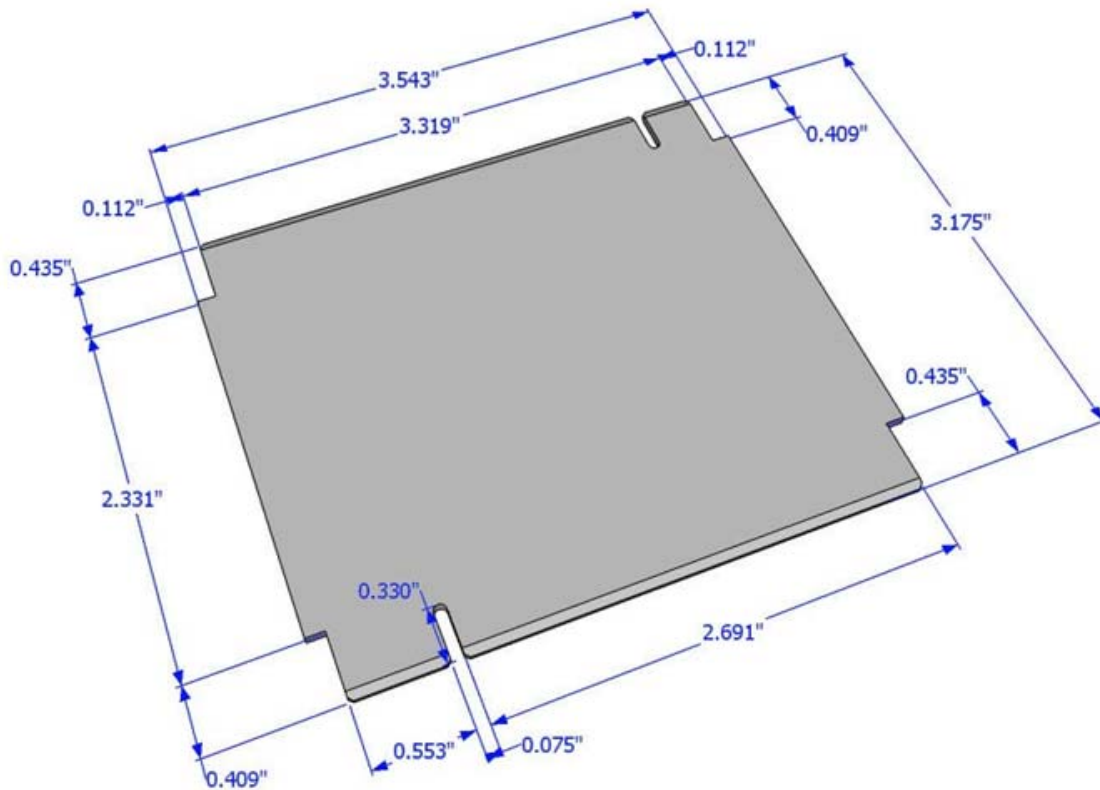

Figure 4. Board dimensions

6 Revision history

Table 5. Revision history

Revision number	Release date	Description
0	02/2015	Initial release