

This document is the property of Amphenol Corporation and is delivered on the express condition that it is not to be disclosed, reproduced or used, in whole or in part, for manufacture or sale by anyone other than Amphenol Corporation without its prior consent, & that no right is granted to disclose or to use any information in this document.

CUSTOMER DRAWING

REVISIONS

SYM	ECN	DESCRIPTION	DATE	APPROVED
1	N/A	FIRST RELEASE	09/11/18	IP
2	N/A	UPDATE THE DRAWING	10/23/18	IP
3	N/A	UPDATE THE DRAWING	11/20/18	IP
4	N/A	UPDATE THE DRAWING	11/30/18	IP
5	N/A	UPDATE THE DRAWING	05/08/19	IP
6	N/A	ADD THE DATE CODE, ADD COLOR FOR HOUSING AND DUST COVER	06/21/19	IP
7	N/A	ADD THE PRE-LOAD	01/08/20	IP
8	N/A	ADD THE COVER CORE OUT	07/24/20	IP

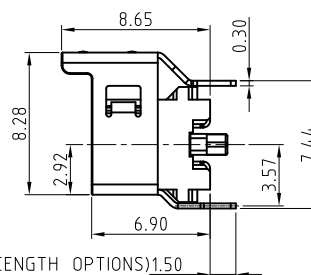
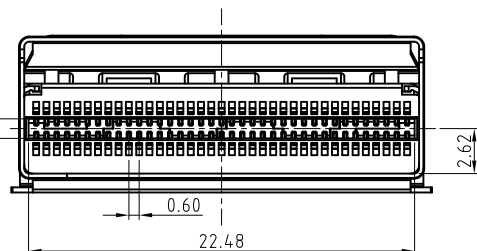
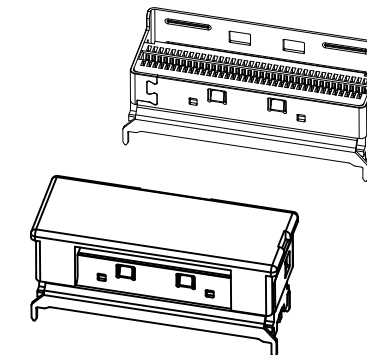
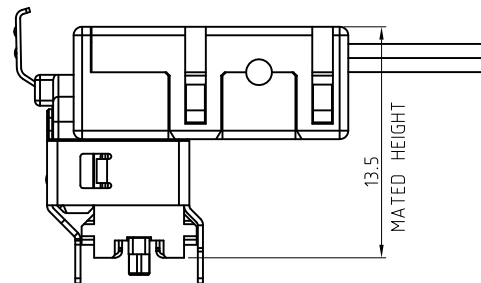
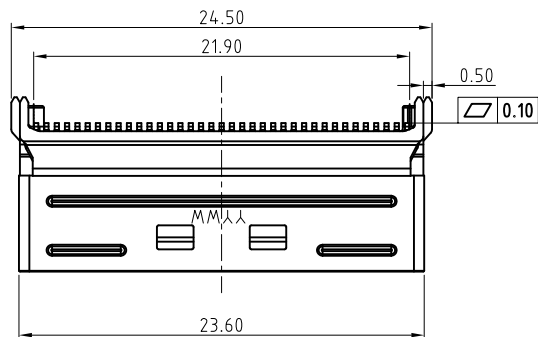

(SEE LATCH PIN LENGTH OPTIONS) 1.50

NOTES:

- MATERIAL:
HOUSING: SOLDER REFLOW PROCESS COMPATIBLE LCP, UL94V-0, COLOR BLACK
DUST COVER: SOLDER REFLOW PROCESS COMPATIBLE LCP, UL94V-0, COLOR BLACK
CONTACTS: HIGH PERFORMANCE COPPER ALLOY, PLATING REFER TO P/N SYSTEM
LATCH: STAINLESS STEEL, SOLDERABLE NICKEL OVER ALL
- RoHS COMPLIANT
- ORDER P/N SYSTEM:
U10-F274-XXXX

- Options
0T: standard construction with tape & reel
1T: no resonance damping feature with tape & reel

LATCH PIN LENGTH OPTIONS

- 1.50
- 2.20
- 3.00
- 4.20

CONTACT PLATING OPTION

- 2: 30 MICROINCHES OF GOLD ON MATING END WITH MATTE TIN ON SOLDER TERMINATION, NICKEL UNDERPLATE ALL OVER
- 3: 15 MICROINCHES OF GOLD ON MATING END WITH MATTE TIN ON SOLDER TERMINATION, NICKEL UNDERPLATE ALL OVER

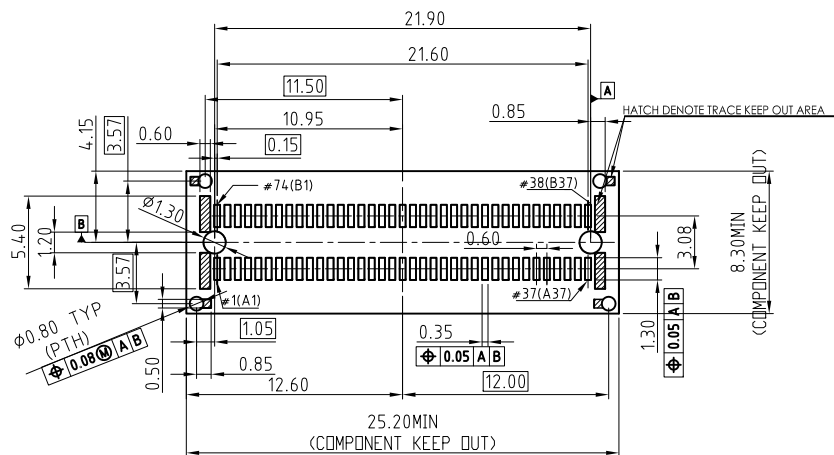

UNLESS OTHERWISE SPECIFIED TOLERANCES		APPROVAL		DATE	Amphenol Amphenol East Asia Limited
		DRAWN		07/24/20	
.X	+/- 0.20	CHECKED Victor.Li		07/24/20	
.XX	+/- 0.15	CHECKED Tony.Tang		07/24/20	
.XXX	+/- 0.10	CHECKED			
FRACTIONS +/- 2'		DRAWING FILE:			TITLE
ANGLES +/-					SLIMSAS Low Profile x8 Receptacle Vertical
FOR MATERIALS AND FINISHES REMOVE SHARP EDGES		ANGLE OF PROJECTION			SIZE
DIMENSIONS		DRAWING NO.			REV.
U.S.	INCHES	A3		U10-F274-XXXX	8
(METRIC)	(MM)	SCALE		2:1	SHEET 1 OF 1