

# Ultrasonic Diffuse, Analogue and Digital Output Types UA18EAD.....TI

CARLO GAVAZZI



- Cylindrical M18 Stainless Steel INOX AISI 316L housing
- Sensing distance: 50-1500 mm
- Power supply: 15 to 30 VDC
- Outputs: 0-10 VDC or 4-20 mA and one switching output NPN or PNP, NO or NC.
- Linearity error 1%
- Repeatability 0.5%
- Beam angle.  $\pm 7^\circ$  or  $\pm 10^\circ$
- Protection: Short-circuit, reverse polarity and overvoltage
- Protection degree IP 67
- 2 m cable or M12 plug



## Product Description

A family of diffuse ultrasonic sensors in Stainless steel housing and with sensing range from 50-400 mm, 100-900 mm and 200-1500 with a resolution as low as 1.0 mm.

The sensor contains both an analogue and a digital output. The output is either 0-10V or 4-20 mA and the digital output NPN or PNP, NO

or NC which forms a window detection. The sensor is the ideal choice for distance measurement, level measurement, diameter measurement or loop control.

Due to use of microprocessor control the digital filtering makes the sensor immune to most electromagnetic interferences.

## Ordering Key

**UA18EAD04NGM1TI**

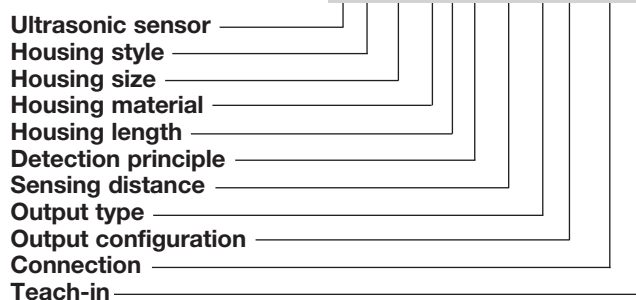

## Type Selection

Housing diameter	Connection	Rated operating dist. (S <sub>n</sub> )	Analog Output	Digital output NPN/PNP	Ordering no.
M18	Plug M12	50-400 mm	4-20 mA	NPN	UA 18 EAD 04 NG M1 TI
M18	Cable	50-400 mm	4-20 mA	NPN	UA 18 EAD 04 NG TI
M18	Plug M12	50-400 mm	0-10 V	NPN	UA 18 EAD 04 NK M1 TI
M18	Cable	50-400 mm	0-10 V	NPN	UA 18 EAD 04 NK TI
M18	Plug M12	50-400 mm	4-20 mA	PNP	UA 18 EAD 04 PG M1 TI
M18	Cable	50-400 mm	4-20 mA	PNP	UA 18 EAD 04 PG TI
M18	Plug M12	50-400 mm	0-10 V	PNP	UA 18 EAD 04 PK M1 TI
M18	Cable	50-400 mm	0-10 V	PNP	UA 18 EAD 04 PK TI
M18	Plug M12	100-900 mm	4-20 mA	NPN	UA 18 EAD 09 NG M1 TI
M18	Cable	100-900 mm	4-20 mA	NPN	UA 18 EAD 09 NG TI
M18	Plug M12	100-900 mm	0-10 V	NPN	UA 18 EAD 09 NK M1 TI
M18	Cable	100-900 mm	0-10 V	NPN	UA 18 EAD 09 NK TI
M18	Plug M12	100-900 mm	4-20 mA	PNP	UA 18 EAD 09 PG M1 TI
M18	Cable	100-900 mm	4-20 mA	PNP	UA 18 EAD 09 PG TI
M18	Plug M12	100-900 mm	0-10 V	PNP	UA 18 EAD 09 PK M1 TI
M18	Cable	100-900 mm	0-10 V	PNP	UA 18 EAD 09 PK TI
M18	Plug M12	200-1500 mm	4-20 mA	NPN	UA 18 EAD 15 NG M1 TI
M18	Cable	200-1500 mm	4-20 mA	NPN	UA 18 EAD 15 NG TI
M18	Plug M12	200-1500 mm	0-10 V	NPN	UA 18 EAD 15 NK M1 TI
M18	Cable	200-1500 mm	0-10 V	NPN	UA 18 EAD 15 NK TI
M18	Plug M12	200-1500 mm	4-20 mA	PNP	UA 18 EAD 15 PG M1 TI
M18	Cable	200-1500 mm	4-20 mA	PNP	UA 18 EAD 15 PG TI
M18	Plug M12	200-1500 mm	0-10 V	PNP	UA 18 EAD 15 PK M1 TI
M18	Cable	200-1500 mm	0-10 V	PNP	UA 18 EAD 15 PK TI

## Specifications

<b>Rated operating distance (S<sub>n</sub>)</b>	Reference target: 1 mm metal rolled finish. EAD04: 100 x 100 mm EAD09 and EAD15: 200 x 200 mm 50 - 400 mm 100 - 900 mm 200 - 1500 mm	<b>Operating frequency digital output (f)</b> UA18EAD04... ≤ 10 Hz UA18EAD09... ≤ 4 Hz UA18EAD15... ≤ 1 Hz
UA18EAD04 UA18EAD09 UA18EAD15		<b>Response time OFF-ON digital output (t<sub>ON</sub>)</b> UA18EAD04... ≤ 50 mS UA18EAD09... ≤ 125 mS UA18EAD15... ≤ 500 mS
<b>Blind zone</b>		<b>Response time ON-OFF digital output (t<sub>OFF</sub>)</b> UA18EAD04... ≤ 50 mS UA18EAD09... ≤ 125 mS UA18EAD15... ≤ 500 mS
UA18EAD04... ≤ 50 mm UA18EAD09... ≤ 100 mm UA18EAD15... ≤ 200 mm		<b>Response time analog output</b> ≤ 500 mS
<b>Repeatability</b>	0.5%	<b>Power ON delay</b> ≤ 500 mS
<b>Linear Accuracy</b>	1%	<b>Output function, open collector</b> By sensor type NPN or PNP
<b>Beam angle</b>		<b>Output switching function</b> One open collector transistor and one analogue output to be configured as: Window function with N.O or N.C. output. Analogue output with positive or negative slope.
UA18EAD04... ±10° UA18EAD09... ±7° UA18EAD15... ±7°		<b>Indication Output ON</b> Yellow LED
<b>Sensitivity</b>		<b>Environment</b>
Push-button P1 (farthest setpoint) P2 (nearest setpoint)		Installation category III (IEC 60664/60664A; 60947-1) Pollution degree 3 (IEC 60664/60664A; 60947-1) Degree of protection IP67 (IEC 60529; 60947-1)
Resolution 1 mm		<b>Ambient temperature</b> Operating -20° to +60°C (-4° to +140°F) Storage -35° to +70°C (-31° to +158°F)
<b>Temperature drift</b>	0.1%/°C @ -20° to +60° C	<b>Vibration</b> 10 to 55 Hz, 1.0 mm/6g (IEC/EN 60068-2-6)
<b>Temperature compensation</b>	Yes	<b>Shock</b> 30 g / 11 ms, 3 directions (IEC/EN 60068-2-27)
<b>Hysteresis (H)</b>	Min. 1%	<b>Rated insulation voltage</b> < 500 VAC (rms)
<b>Rated operational voltage (U<sub>B</sub>)</b>	15 to 30 VDC (ripple included)	<b>Housing</b>
<b>Ripple (U<sub>pp</sub>)</b>	≤ 5%	Material body AISI 316L Material front Epoxy-glass resin Material back, plug Grilamid Material back, cable Grilamid Material trimmer POM Sealing around trimmer TPE Material sealing front UA18EAD04... TPE UA18EAD09... TPE UA18EAD15... TPE
<b>No-load supply current (I<sub>o</sub>)</b>		<b>Connection</b>
UA18EAD04... 50 mA @ U <sub>B</sub> max UA18EAD09... 50 mA @ U <sub>B</sub> max UA18EAD15... 50 mA @ U <sub>B</sub> max		Cable PVC, grey, 2 m, 4 x 0.32 mm <sup>2</sup> , Ø = 4.7 mm M12, 4-pin (CON. 14-series)
<b>Output current continuous digital output (I<sub>o</sub>)</b>		<b>Tightening torque</b> ≤ 50 Nm
Max. load capacity 100 nF UL508 specification 100 mA 100 mA		
<b>Output current short-time digital output (I)</b>		
Max. load capacity 100 nF UL508 specification 100 mA 100 mA		
<b>Minimum operational current digital output (I<sub>m</sub>)</b>	0.5 mA	
<b>OFF-state current digital output (I<sub>o</sub>)</b>	10 µA	
<b>Voltage drop digital output (U<sub>d</sub>)</b>	≤ 2.2 VDC @ I <sub>g</sub> max.	
<b>Protection digital output</b>	Short-circuit, overvoltage and reverse polarity	
<b>Output analog output</b>		
NG.. or PG.. types 4 to 20 mA NK.. or PK.. types 0 to 10 VDC		
<b>Load</b>		
4 to 20 mA 0 to 10 VDC	max. 500 Ω min. 3 kΩ	
<b>Carrier frequency</b>		
UA18EAD04... 300 kHz UA18EAD09... 300 kHz UA18EAD15... 200 kHz		

## Specifications (cont.)

<b>Weight</b>	
Cable version	125 g
Plug version	55 g

<b>CE-marking</b>	Yes
<b>Approvals</b>	cULus (UL508)

## Wiring Diagram

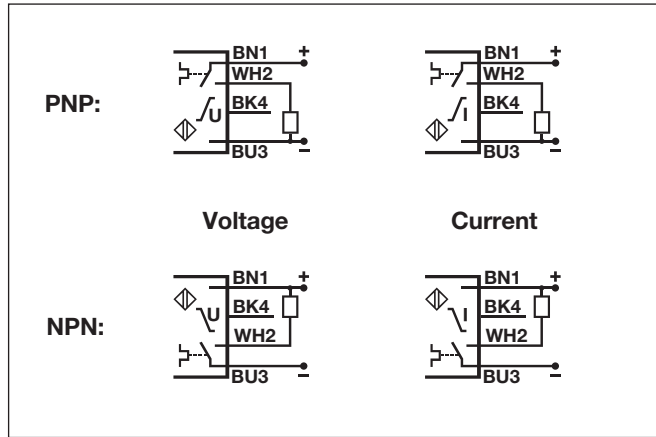

## Detection Range

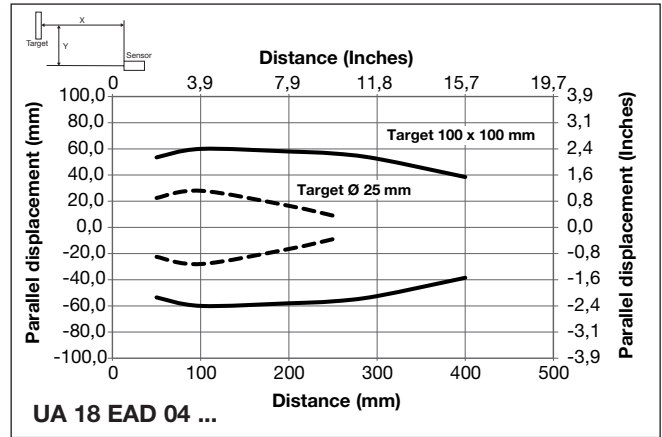

## Dimensions

