

UA5M15MP Eval Board

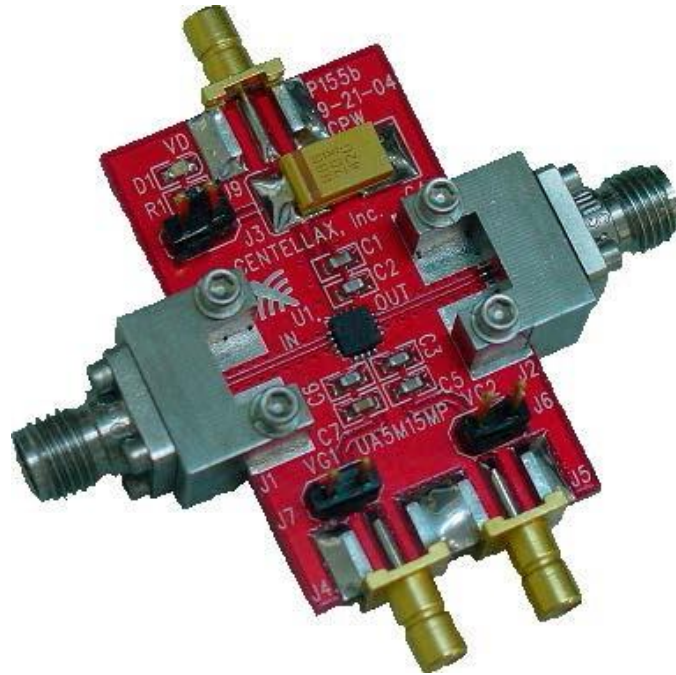

Figure 1. UA5M15MP

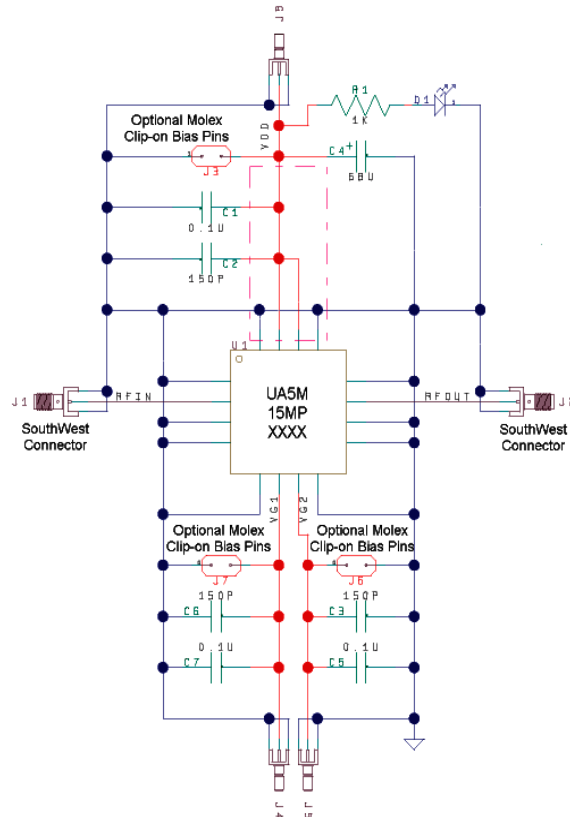

Figure 2. UA5M15MPE Evaluation Board

Evaluation Board Application Notes

1. Connect RFIN and RFOUT to 50W measurement system (connectors are SouthWest 2.92mm K-connectors, compatible with SMA)
2. Apply +3.3V or +5.0V drain bias voltage to VD1 and VD2 through the single SMB connector at the top of the board, or by connecting to the J3 Molex clip-on bias pins (see schematic)
3. Optionally connect 1st and/or 2nd stage gate bias voltages to VG1 and/or VG2 through the double SMB connectors at the bottom of the board, or by connecting to the Molex clip-on bias pins
4. Optionally adjust VG1 and/or VG2 for optimal application-specific performance