

## PROTECTION PRODUCTS

### Description

μClamp® series of TVS arrays are designed to protect sensitive electronics from damage or latch-up due to ESD and surge. They feature large cross-sectional area junctions for conducting high transient currents. They offer desirable characteristics for board level protection including fast response time, low operating and clamping voltage, and no device degradation.

μClamp0501P is in a 2-pin SLP1006P2 package, measuring 1.0 x 0.6 x 0.5mm. Leads are spaced at a pitch of 0.65mm and are finished with lead-free NiPdAu. Each device will protect one uni-directional line operating at 5 volts. They may be used to meet the ESD immunity requirements of IEC 61000-4-2 ( $\pm 15$ kV contact &  $\pm 20$  air discharge). The combination of small size and high ESD surge capability makes them ideal for use in applications such as cellular phones, industrial equipment, and portable instrumentation.

### Features

- High ESD withstand Voltage:  $\pm 15$ kV (Contact) and  $\pm 20$ kV (Air) per IEC 61000-4-2
- Ultra-small package(1.0 x 0.6 x 0.5mm)
- Protects one I/O or power line
- Low ESD clamping voltage
- Working voltage: +5V
- Low leakage current
- Solid-state silicon-avalanche technology

### Mechanical Characteristics

- SLP1006P2 package
- Pb-Free, Halogen Free, RoHS/WEEE Compliant
- Lead Finish: NiPdAu
- Marking: Marking code
- Packaging: Tape and Reel

### Applications

- Cellular Handsets & Accessories
- OLED Displays
- VBUS
- Notebooks & Handhelds
- Portable Instrumentation

### Package Dimension

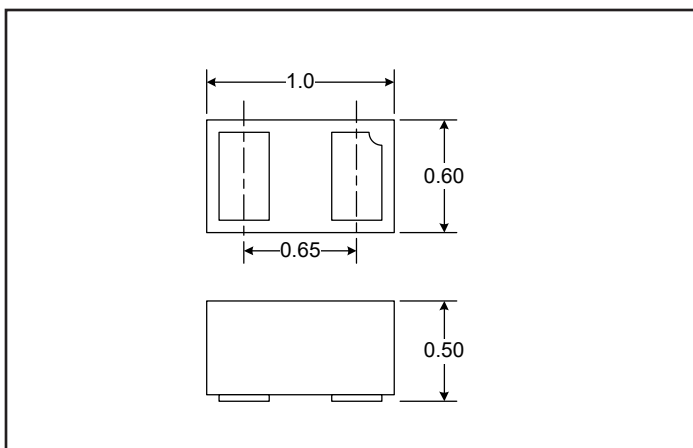

### Schematic & Pin Configuration

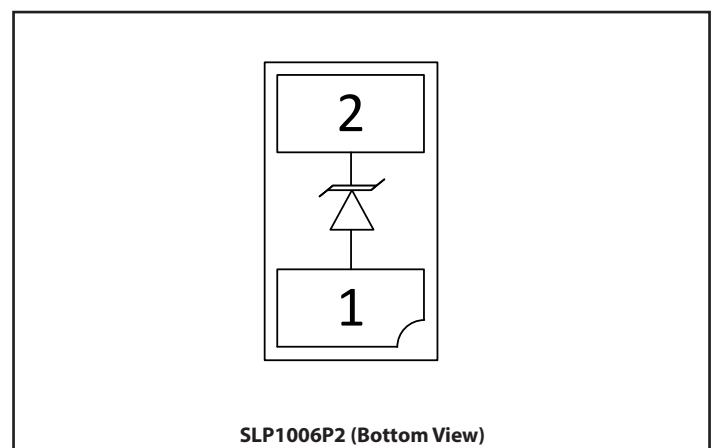

## Absolute Maximum Rating

Rating	Symbol	Value	Units
Peak Pulse Power ( $t_p = 8/20\mu s$ )	$P_{PK}$	200	W
Peak Pulse Current ( $t_p = 8/20\mu s$ )	$I_{PP}$	16	A
ESD per IEC 61000-4-2 (Air) <sup>(1)</sup> ESD per IEC 61000-4-2 (Contact) <sup>(1)</sup>	$V_{ESD}$	$\pm 20$ $\pm 15$	kV
Operating Temperature	$T_{OP}$	-55 to +125	°C
Storage Temperature	$T_{STG}$	-55 to +150	°C

## Electrical Characteristics (T=25°C unless otherwise specified)

Parameter	Symbol	Conditions	Min.	Typ.	Max.	Units
Reverse Stand-Off Voltage	$V_{RWM}$	Pin 2 to 1			5	V
Reverse Breakdown Voltage	$V_{BR}$	$I_t = 1\text{mA}$ , Pin 2 to 1	6			V
Reverse Leakage Current	$I_R$	$V_{RWM} = 5\text{V}$ , Pin 2 to 1			5	$\mu\text{A}$
Forward Voltage	$V_F$	$I_F = 10\text{mA}$ , Pin 1 to 2		0.8		V
Clamping Voltage	$V_C$	$I_{PP} = 5\text{A}$ , $t_p = 8/20\mu s$ , Pin 2 to 1			9.8	V
		$I_{PP} = 16\text{A}$ , $t_p = 8/20\mu s$ , Pin 2 to 1			12.5	
Junction Capacitance	$C_J$	$V_R = 0\text{V}$ , $f = 1\text{MHz}$			160	pF

Notes: 1) ESD gun return path connected to ESD ground plane

# Typical Characteristics

### Non-Repetitive Peak Pulse Power vs. Pulse Time

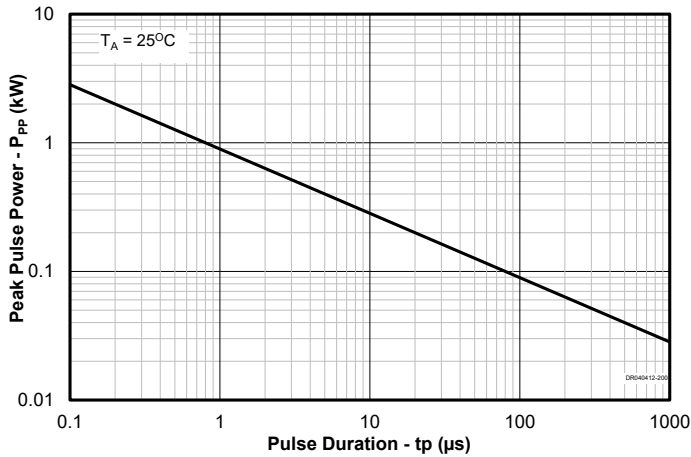

### Power Derating Curve

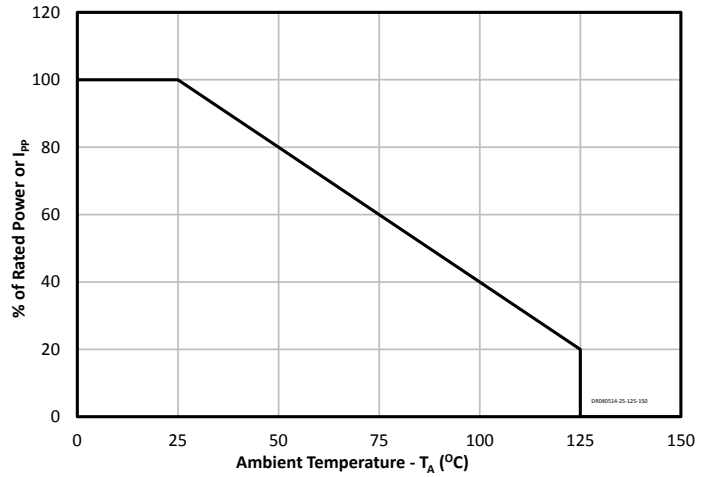

### Clamping Voltage vs. Peak Pulse Current

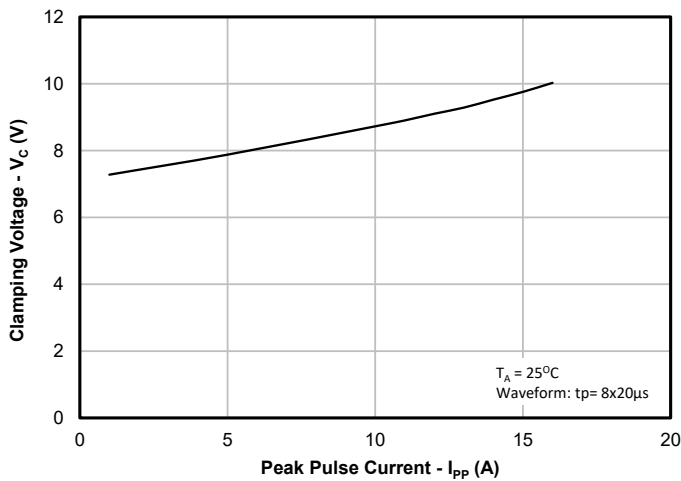

### Forward Voltage vs. Forward Current

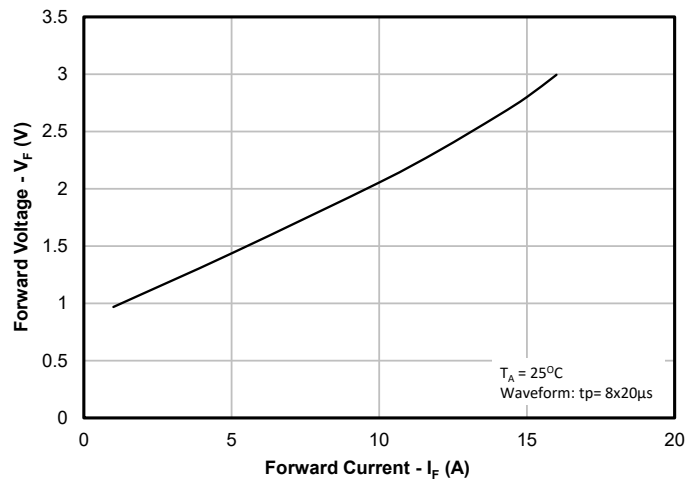

### Normalized Junction Capacitance vs. Reverse Voltage

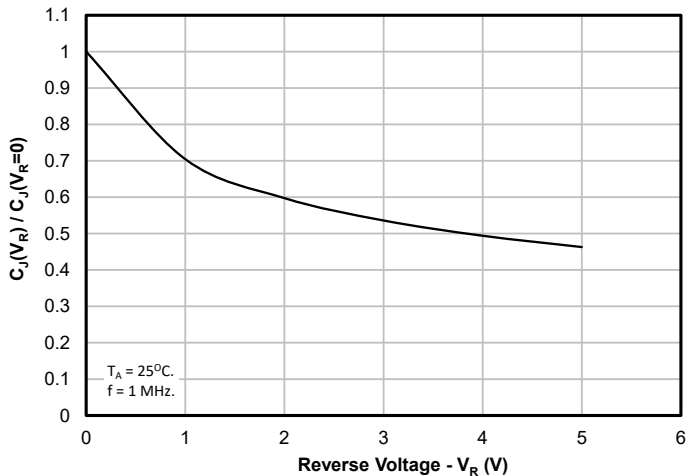

### ESD Clamping (8kV Contact per IEC 61000-4-2)

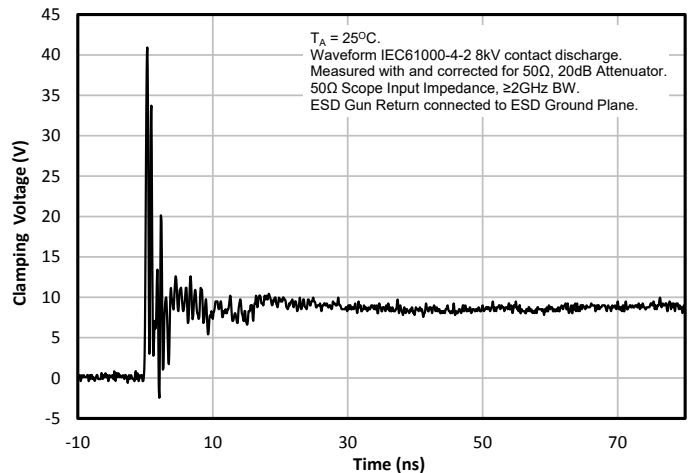

## Outline Drawing - SLP1006P2

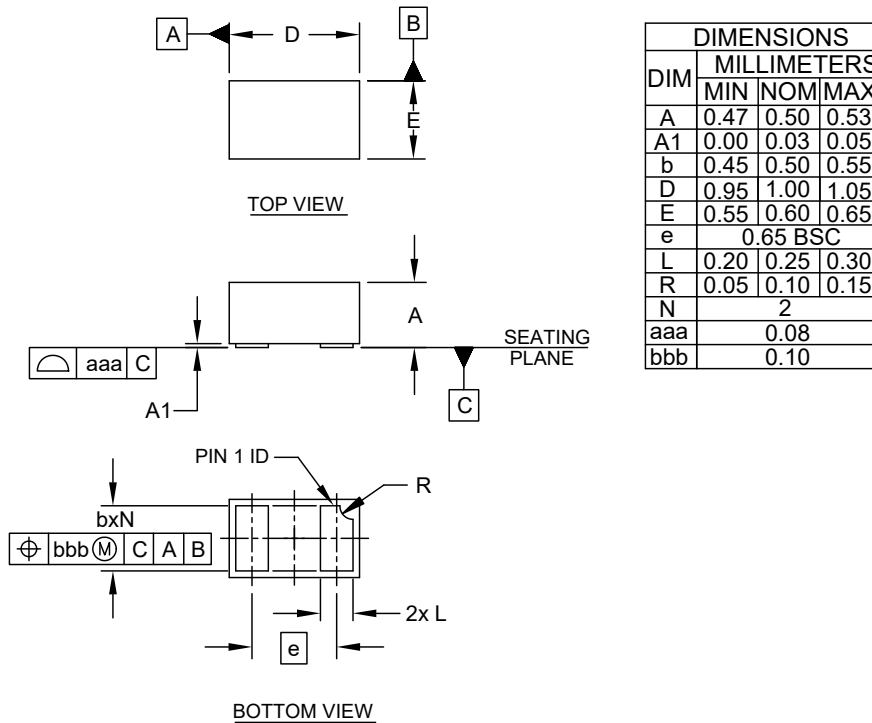

### NOTES:

1. CONTROLLING DIMENSIONS ARE IN MILLIMETERS (ANGLES IN DEGREES).

## Land Pattern - SLP1006P2

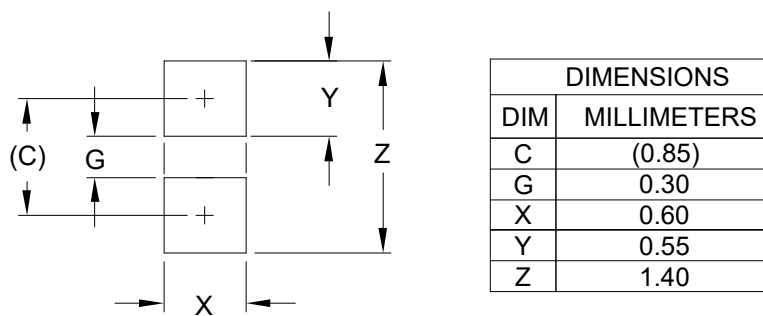

### NOTES:

1. CONTROLLING DIMENSIONS ARE IN MILLIMETERS (ANGLES IN DEGREES).
2. THIS LAND PATTERN IS FOR REFERENCE PURPOSES ONLY. CONSULT YOUR MANUFACTURING GROUP TO ENSURE YOUR COMPANY'S MANUFACTURING GUIDELINES ARE MET.

# Marking Code

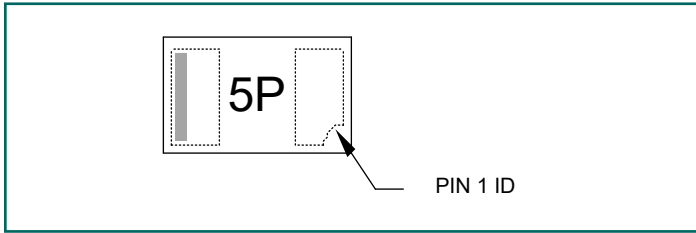

Note: Cathode bar at Pin 2

# Tape and Reel Specification

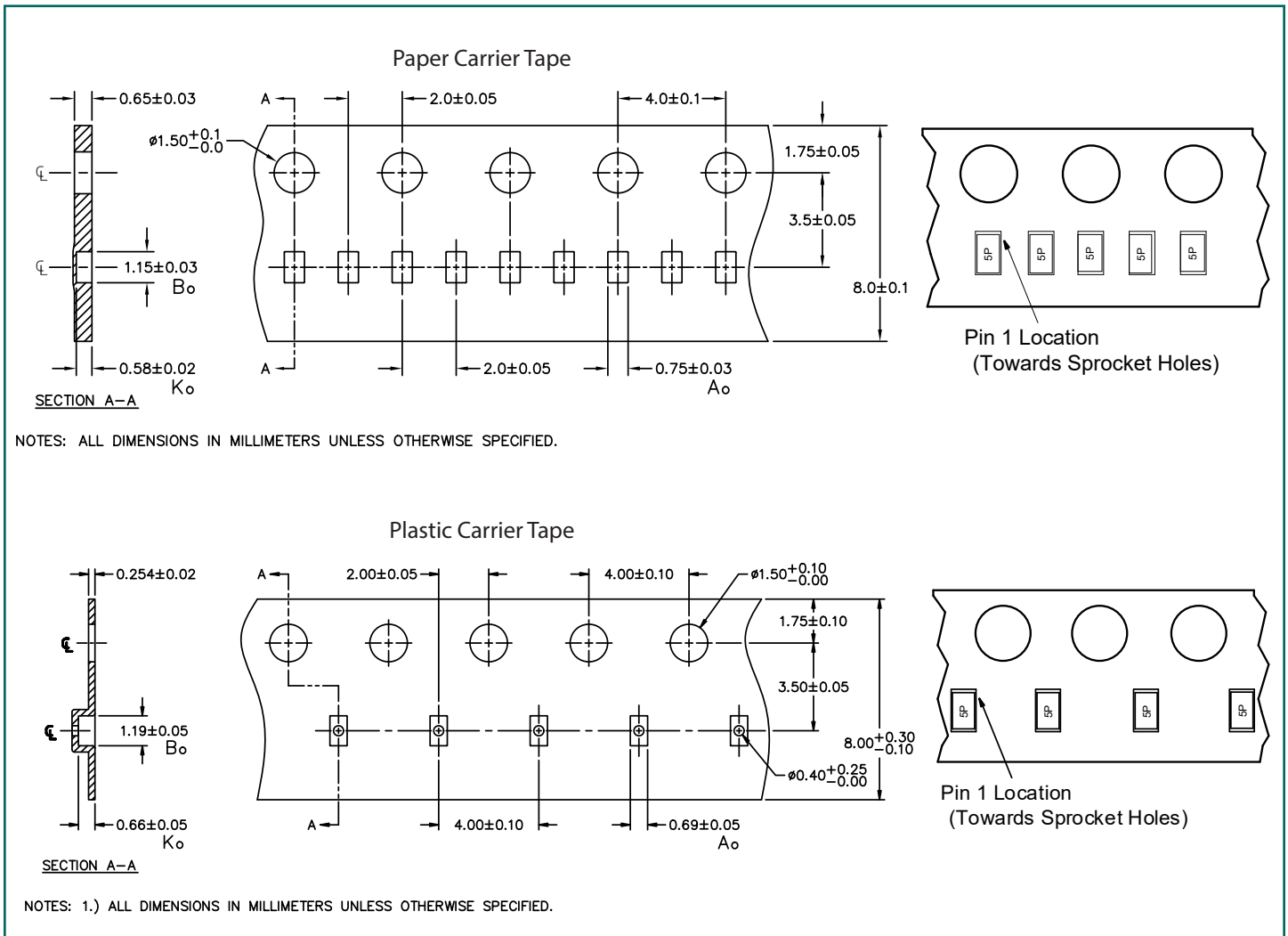

# Ordering Information

Part Number	Qty per Reel	Tape Material	Reel Size
$\mu$ Clamp0501P.TFT	15000	Paper	7 Inch
$\mu$ Clamp0501P.TCT	3000	Plastic	7 Inch

MicroClamp, uClamp and  $\mu$ Clamp are registered trademarks of Semtech Corporation.