

**SURFACE MOUNT GLASS PASSIVATED  
SUPER FAST SILICON RECTIFIER  
VOLTAGE RANGE 50 to 200 Volts CURRENT 3.0 Ampere**

**FEATURES**

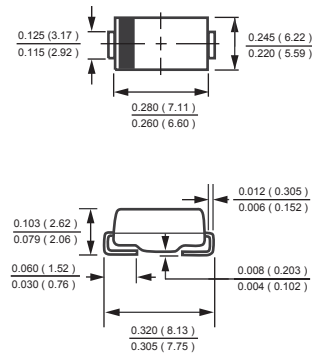
- \* Glass passivated device
- \* For surface mounted applications
- \* Ultrafast recovery times dor high efficiency
- \* Low forward voltage, low power loss
- \* Low leakage current

**MECHANICAL DATA**

- \* Epoxy: Device has UL flammability classification 94V-0
- \* Metallurgically bonded construction
- \* Mounting position: Any
- \* Weight: 0.24 gram



**DO-214AB**



**MAXIMUM RATINGS AND ELECTRICAL CHARACTERISTICS**

Ratings at 25 °C ambient temperature unless otherwise specified.  
Single phase, half wave, 60 Hz, resistive or inductive load.  
For capacitive load, derate current by 20%.

**MAXIMUM RATINGS (@ TA=25 °C unless otherwise noted)**

RATINGS	SYMBOL	UFM301	UFM302	UFM303	UFM304	UNITS
Maximum Recurrent Peak Reverse Voltage	$V_{RRM}$	50	100	150	200	Volts
Maximum RMS Voltage	$V_{RMS}$	35	70	105	140	Volts
Maximum DC Blocking Voltage	$V_{DC}$	50	100	150	200	Volts
Maximum Average Forward Rectified Current at $T_A = 55^\circ\text{C}$	$I_O$	3.0				Amps
Peak Forward Surge Current 8.3 ms single half sine-wave superimposed on rated load (JEDEC method)	$I_{FSM}$	100				Amps
Typical Thermal Resistance (Note 1)	$R_{\theta JA}$	47				$^\circ\text{C/W}$
Typical Thermal Resistance (Note 1)	$R_{\theta JL}$	12				$^\circ\text{C/W}$
Typical Junction Capacitance (Note 2)	$C_J$	45				pF
Operating Temperature Range	$T_J$	150				$^\circ\text{C}$
Storage Temperature Range	$T_{STG}$	-55 to + 150				$^\circ\text{C}$

**ELECTRICAL CHARACTERISTICS(@TA=25 °C unless otherwise noted)**

CHARACTERISTICS	SYMBOL	UFM301	UFM302	UFM303	UFM304	UNITS
Maximum Instantaneous Forward Voltage at 3.0A DC	$V_F$	0.9				Volts
Maximum Average Reverse Current at Rated DC Blocking Voltage	@ $T_A = 25^\circ\text{C}$	5				$\mu\text{A}$
	@ $T_A = 100^\circ\text{C}$	500				$\mu\text{A}$
Maximum Reverse Recovery Time (Note 4)	$t_{rr}$	20				nSec

- NOTES : 1. Thermal Resistance :Mounted on PCB.  
2. Measured at 1 MHz and applied reverse voltage of 4.0 volts.  
3. "Fully ROHS compliant", "100% Sn plating (Pb-free)".  
4. Test Conditions:  $I_F = 0.5\text{A}$ ,  $I_R = -1.0\text{A}$ ,  $I_{RR} = -0.25\text{A}$ .

## RATING AND CHARACTERISTICS CURVES ( UFM301 THRU UFM304 )

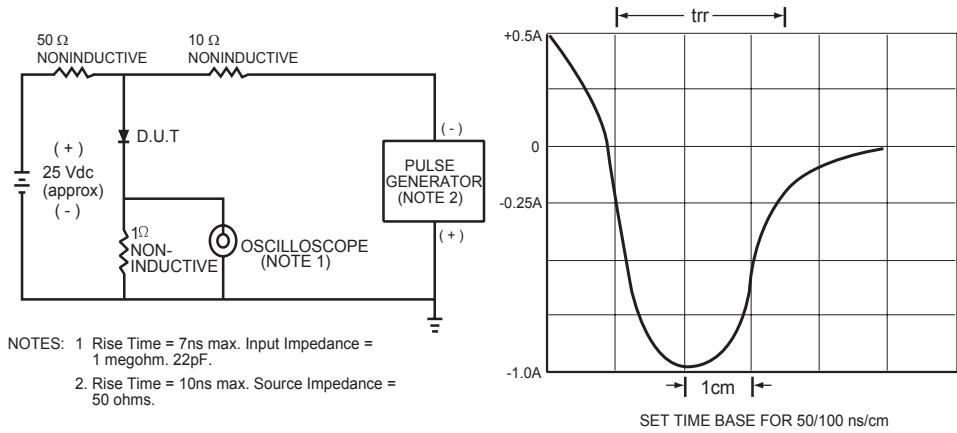


FIG.1 TEST CIRCUIT DIAGRAM AND REVERSE RECOVERY TIME CHARACTERISTIC

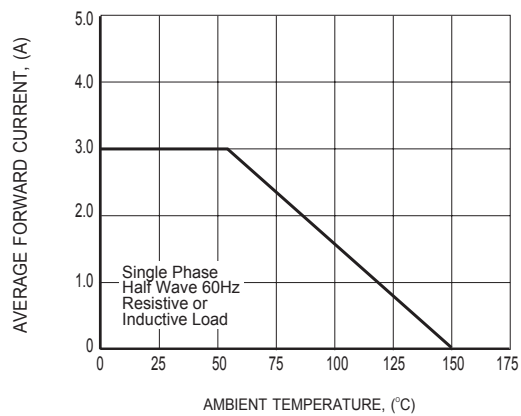


FIG.2 TYPICAL FORWARD CURRENT DERATING CURVE

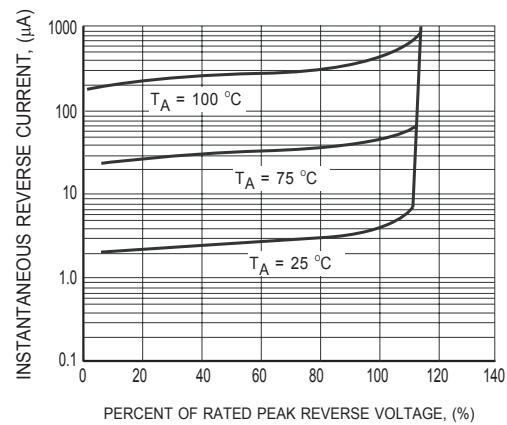
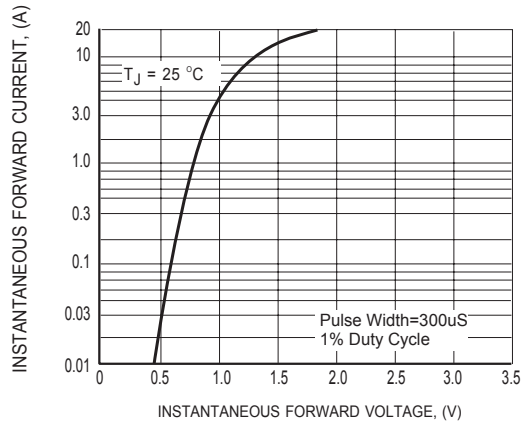
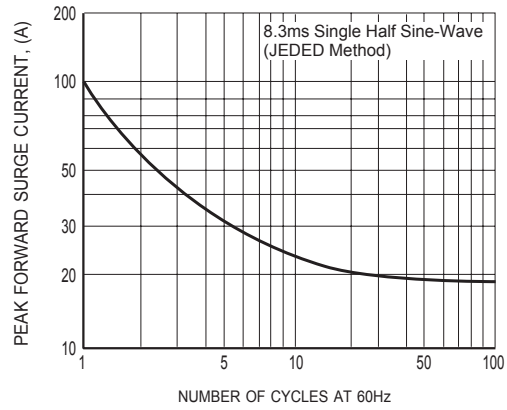


FIG.3 TYPICAL REVERSE CHARACTERISTICS

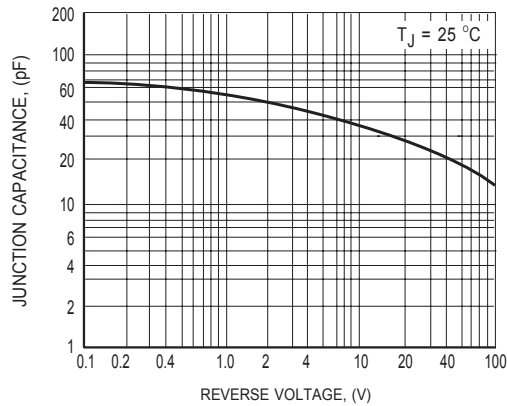
## RATING AND CHARACTERISTICS CURVES ( UFM301 THRU UFM304 )



**FIG.4 TYPICAL INSTANTANEOUS FORWARD CHARACTERISTICS**

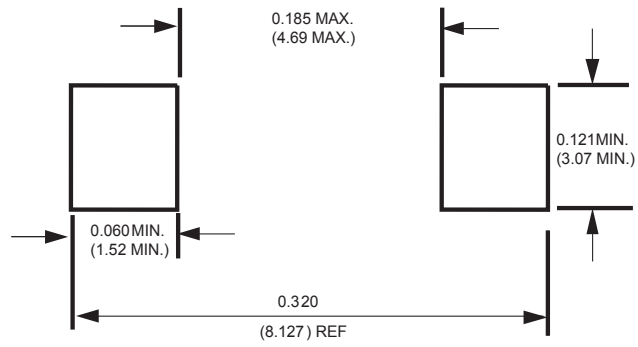


**FIG.5 MAXIMUM NON-REPETITIVE FORWARD SURGE CURRENT**



**FIG.6 TYPICAL JUNCTION CAPACITANCE**

## Mounting Pad Layout



Dimensions in inches and (millimeters)