

Product Introduction

Summary

Ultrasonic Liquid Level Sensor (ULD_2) is designed for non-contact measurement of liquid level height in the closed container. The sensor can be installed directly below the measured container to detect the liquid level height and is IP67 compliant. It can accurately measure the liquid level of various toxic substances such as acids, alkalis and various pure liquids in high temperature and high pressure sealed containers. ULD may be deployed for various high-density container material such as steel, plastic, ceramics, and non-foaming plastics.

Device Characteristics

Description	Value	Unit
Input voltage	2.8~ 5	V _{DC}
Standby current	1	μA
Average current ¹	2.5~15	mA
Detection Range ²	20~2000	mm
Cycling Time	1	s
Output mode	UART/TTL	-
Resolution	1	mm
Response time	1	s
Repeated measurement error ³	+1	mm
Measurement accuracy ³	(5+D*0.5%)	mm
Measuring angle ⁴	3~ 12	°
ESD ⁵	±4 / ±8	KV

Notes:

1. Current consumption decreases with lower input voltage. The current consumption of 1s cycle time with 2.8V input voltage is 2.5mA.
2. To emulate steel container, range obtained on water filled PVC container placed on 2 mm thick steel plate at room temperature.
3. Same test condition as note 2. In the value (5+D*0.5%), D is the liquid level height.
4. Detection angle will increase with rising liquid level.
5. In accordance with IEC61000-4-2

Dimensions

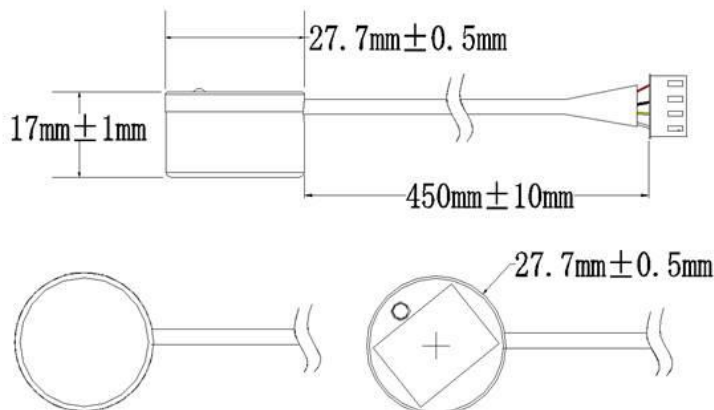

Pin Definition

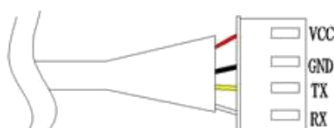

Name	Description
VCC	Power input
GND	Ground
TX/H ⁽¹⁾	UART/TTL output
RX/L ⁽¹⁾	UART input; TTL output

Notes:

1. Vout Max is Vcc.

Absolute Maximum Ratings

Environmental Condition Ratings

Description	Min	Typical	Max	Unit
Storage temperature	-25	25	80	°C
Storage humidity		65%	90%	RH
Operation temperature	-15	25	60	°C
Operation humidity		65%	80%	RH

Electrical Ratings

Description	Specification			Unit	Notes
	min	Typical	Max		
Input voltage	2.8	5	5.25	V	
Peak current			130	mA	5V _{DC}
Input ripple			50	mV	
Input noise			100	mV	

Output Formats

ULD_2 supports various outputs formats and must be selected with the matching model name.

UART

Two operation modes are supported by UART: active and passive operation modes. In active mode, measurement data is pushed out every second. For passive mode, ULD_2 is triggered with falling edge on RX with minimum cycle time of 1s.

UART Communication Description

Data bits	Stop bit	Parity check	Baud rate
8	1	None	9600bps

UART Data Packet Format

Frame data	Description	byte
Header	0xFF	1byte
Data_H	Higher 8 bits of distance data	1byte
Data_L	Lower 8 bits of distance data	1byte
Checksum	Communication checksums	1byte

UART Output Example

Header	Data_H	Data_L	Checksum
0xFF	0x07	0xA1	0xA7

Notes:

Only lower 8 bits of the accumulated value are kept;

Sum = (frame header + Data_H + Data_L) & 0x00ff = 0xA7;

Liquid level value = Data_H && Data_L = 0x07A1 or 1953mm.

TTL

Description	TX Output	RX Output
Liquid detected	Vcc	0V
No detection	0V	Vcc

External LED

LED operation	Description
Off	Module off or idle (when in passive mode).
Constant	Module is active, but no liquid detected.
Flashing	Active output mode: Flashes at 1 second interval. Passive output mode: Flashes when instruction is received.

Model Selection

Part Number	Feature
ULD_2U	UART active
ULD_2P	UART passive. Standby power consumption: 1uA
ULD_2T	TTL output

Reliability Tests

Test items	Test environment
High temp environmental test	60°C, 85%RH, 5V _{IN} for 72hrs
Low temp environmental test	-20°C, 5V _{IN} for 72hrs
High temp storage	80°C, 80%RH for 72hrs
Low temp storage	-30°C for 72hrs
Vibration test	10-200hz, 15min, 2.0g, on XYZ axes for 30 min
Drop test	1.2m free fall on wood surface, repeated 5 times.

Notes: 3 samples are tested for each test items with performance degradation less than 10%.

Design Consideration

1. Detection range will be different pending the conditions listed.
 - Container materials such as steel, glass, iron, ceramic, non-foaming plastics, and other high-density materials.
 - Container wall thickness.
2. UART output will fluctuate under the following conditions.
 - Liquid level exceeds the detection range.
 - Liquid level is tilted or changing.

Revision History

Date	Version	Description
12/01/2019	1.0	Initial Pro-Wave release.
01/13/2020	1.1	Model Selection
10/19/2020	1.2	PNP model obsoleted.
10/27/2020	1.3	Minor description update.