

Description

The DIODES™ ULN62003A is a high-voltage, high-current transistor array containing seven open drain devices, with all of their sources connected to a common ground. The transistors are rated at 500mA with each having a clamp diode for protection needed for driving inductive loads.

The DMOS output construction has a lower on-resistance than the common bipolar devices reducing power dissipation, allowing the designer additional flexibility to control more devices and maintain the desired die temperature.

These devices are capable of driving multiple load types such as solenoids, relays, DC motors, LED displays, filament lamps, thermal print-heads, and high-power buffers.

The device is pinned in opposition to simplify board layout and is a direct replacement for many common peripheral drivers. The ULN62003A is available in an industry-standard, small outline, 16-pin package SO-16 (Type SM).

Pin Assignments

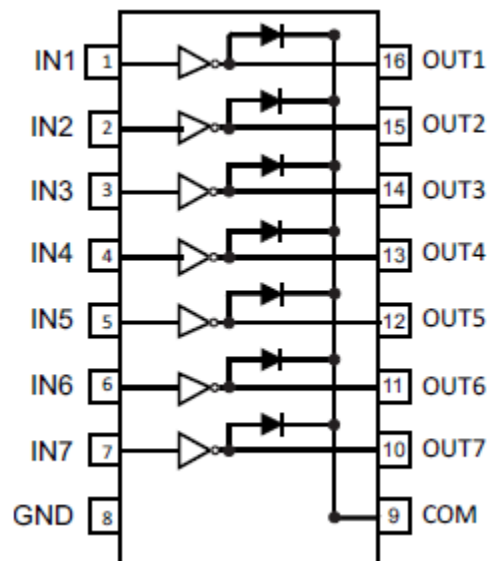

SO-16 (Type SM)

Features

- 500mA Rated Drain Current (Single Output)
- High Voltage Outputs: 50V
- Output Clamp Diodes
- Inputs Compatible with Popular Logic Types
- Relay Driver Applications
- **Totally Lead-Free & Fully RoHS Compliant (Notes 1 & 2)**
- **Halogen and Antimony Free. "Green" Device (Note 3)**
- **For automotive applications requiring specific change control (i.e. parts qualified to AEC-Q100/101/104/200, PPAP capable, and manufactured in IATF 16949 certified facilities), please [contact us](mailto:contact@diodes.com) or your local Diodes representative. <https://www.diodes.com/quality/product-definitions/>**

Applications

- Appliances
 - Window A/Cs
 - Washers/dryers
 - Microwaves/ranges/ovens
- Industrial and agricultural automation
- Residential and industrial HVAC systems
- Stepper motor drivers
- Thermal print heads

Notes: 1. No purposely added lead. Fully EU Directive 2002/95/EC (RoHS), 2011/65/EU (RoHS 2) & 2015/863/EU (RoHS 3) compliant.
2. See <https://www.diodes.com/quality/lead-free/> for more information about Diodes Incorporated's definitions of Halogen- and Antimony-free, "Green" and Lead-free.
3. Halogen- and Antimony-free "Green" products are defined as those which contain <900ppm bromine, <900ppm chlorine (<1500ppm total Br + Cl) and <1000ppm antimony compounds.

Pin Descriptions

Pin Number SO-16 (Type SM)	Pin Name	Function
1	IN1	Input Pair 1
2	IN2	Input Pair 2
3	IN3	Input Pair 3
4	IN4	Input Pair 4
5	IN5	Input Pair 5
6	IN6	Input Pair 6
7	IN7	Input Pair 7
8	GND	Common Source (Ground)
9	COM	Common Clamp Diodes
10	OUT7	Output Pair 7
11	OUT6	Output Pair 6
12	OUT5	Output Pair 5
13	OUT4	Output Pair 4
14	OUT3	Output Pair 3
15	OUT2	Output Pair 2
16	OUT1	Output Pair 1

Functional Block Diagram

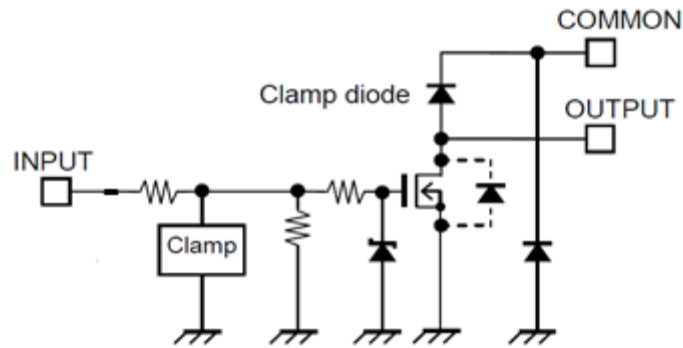

One of Seven Channels

Absolute Maximum Ratings (Note 4) (@T_A = +25°C, unless otherwise specified.)

Symbol	Parameter		Rating	Unit	
V _{OUT}	Output Voltage		50	V	
V _R	Clamp Diode Reverse Voltage (Note 5)		50	V	
V _I	Input Voltage (Note 5)		-1 to 30	V	
I _F	Clamp Diode Forward Current		500	mA	
I _{OUT}	Output Current		500	mA	
θ _{JA}	Thermal Resistance Junction-to-Ambient (Note 6)	SO-16 (Type SM)	B1 (Note 8)	120	°C/W
			B2 (Note 9)	80	°C/W
θ _{JC}	Thermal Resistance Junction-to-Case (Note 7)	SO-16 (Type SM)	B1 (Note 8)	28	°C/W
			B2 (Note 9)	18	°C/W
T _J	Junction Temperature		+150	°C	
T _{STG}	Storage Temperature		-65 to +150	°C	

- Notes:
- Stresses greater than those listed under *Absolute Maximum Ratings* can cause permanent damage to the device. These are stress ratings only, and functional operation of the device at these or any other conditions beyond those indicated under *Recommended Operating Conditions* is not implied. Exposure to *Absolute Maximum Ratings* for extended periods can affect device reliability.
 - All voltage values are with respect to the GND (Pin 8), unless otherwise noted.
 - Maximum power dissipation is a function of T_J (max), θ_{JA} and T_A. The maximum allowable power dissipation at any allowable ambient temperature is P_D = (T_J (max) - T_A)/θ_{JA}. Operating at the absolute maximum T_J of +150°C can affect reliability.
 - Maximum power dissipation is a function of T_J (max), θ_{JC} and T_A. The maximum allowable power dissipation at any allowable ambient temperature is P_D = (T_J (max) - T_C)/θ_{JC}. Operating at the absolute maximum T_J of +150°C can affect reliability.
 - B1: test performed on PCB (25.4mm x 25.4mm x 1.6mm, 1 signal layer, no GND plane, 2oz Cu thickness, FR4 substrate). This configuration results in a maximum power dissipation of 1.04 watts at T_A = +25°C. When T_A exceeds +25°C, max P_d is derated 8.3mW/°C.
 - B2: test performed on JEDEC 2s2p High K board. This configuration results in a maximum power dissipation of 1.56 watts at T_A = +25°C. When T_A exceeds +25°C, max P_d is derated 12.5mW/°C.

Recommended Operating Conditions

Symbol	Parameter	Min	Max	Unit
V _{CC}	Drain to Source Voltage	—	50	V
T _A	Operating Ambient Temperature	-40	+125	°C

Electrical Characteristics (@T_A = +25°C, unless otherwise specified.)

ULN62003A								
Parameter		Test Figure	Test Conditions		Min	Typ	Max	Unit
V _{out}	Output Voltage	—	—	—	—	—	50	V
V _{com}	COM Pin Voltage	—	—	—	0	—	50	V
I _{out}	Output Current	—	1 circuit on	—	0	—	400	mA
	—	Duty = 10%	7 circuit on	T _{pw} = 25ms T _A = +85°C T _J = +125°C	—	—	270	mA
	—	Duty = 50%	7 circuits on	T _{pw} = 25ms T _A = +85°C T _J = +125°C	—	—	120	mA
V _{in(on)}	Input Voltage	—	I _{out} = 100mA or upper	V _{out} = 2V	2.5	—	25	V
V _{in(off)}	Input Voltage	—	I _{out} = 100μA or less	V _{out} = 2V	0	—	0.6	V
I _F	Clamp Diodes Forward Current	—	—	—	—	—	400	mA
I _{leak}	Output Leakage Current	1	V _{out} = 50V, T _A = +85°C	V _{in} = 0V	—	—	1	μA
V _{ds}	Output Voltage (Output On-Resistance)	2	I _{out} = 350mA	V _{in} = 5.0V	—	0.7	1.14	V
			—	—	—	2.0	3.25	Ω
			I _{out} = 200mA	V _{in} = 5V	—	0.4	0.65	V
			—	—	—	2	3.25	Ω
			I _{out} = 100mA	V _{in} = 5V	—	0.2	0.325	V
—	—	—	2.0	3.25	Ω			
I _{in(on)}	Input Current (Output On)	3	V _{in} = 2.5V	—	—	—	0.1	mA
I _{in(off)}	Input Current (Output Off)	4	V _{in} = 0, T _A = +85°C	—	—	—	1	μA
I _{in(off)_N}	Input Current (Output Off)	3	V _{in} = -1.0V T _A = 0 to +85°C	—	—	0.1	4	mA
V _{in(On)}	Input Voltage (Output On)	5	I _{out} = 100mA	V _{out} = 2V	—	—	2.5	V
I _R	Clamp Diodes Reverse Current	6	V _R = 50V	T _A = +85°C	—	—	1.0	μA
V _F	Clamp Diodes Forward Voltage	7	I _F = 350mA	—	—	—	2.0	V
t _{on}	Turn-On Delay	8	V _{out} = 50V	R _L = 125Ω C _L = 15Pf	—	0.4	—	μs
t _{off}	Turn-Off Delay	8	—	—	—	0.8	—	μs

Parameter Measurement Circuits

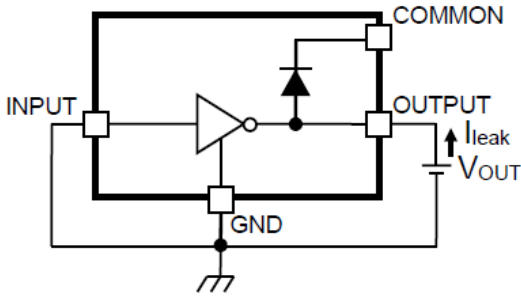

Fig.1 Ileak

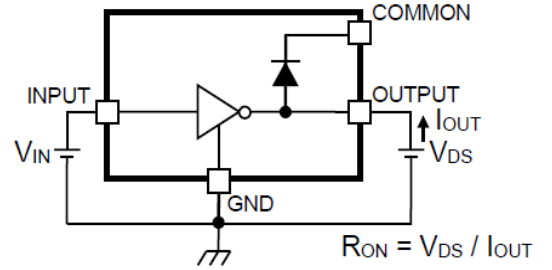

Fig.2 VDS

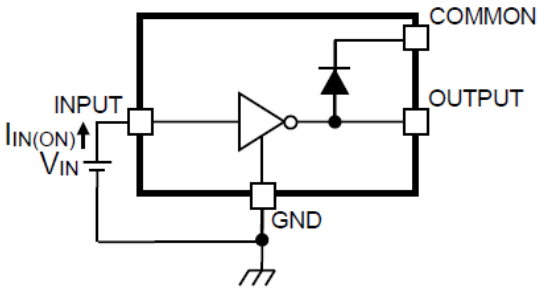

Fig.3 IIN(ON)

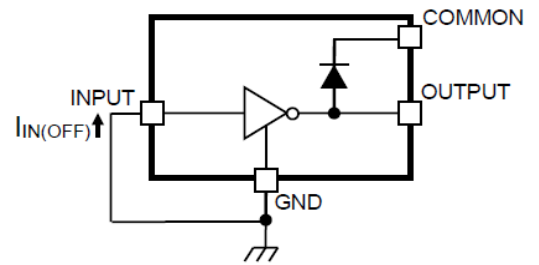

Fig.4 IIN(OFF)

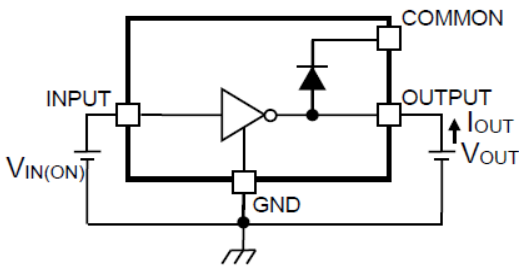

Fig.5 VIN(ON)

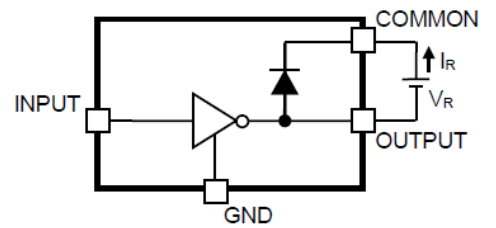

Fig.6 IR

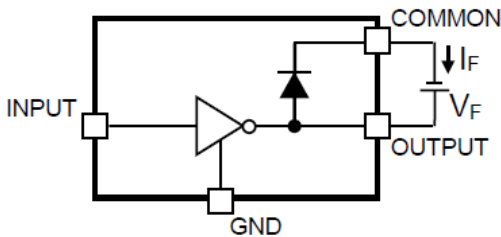

Fig.7 VF

Parameter Measurement Circuits (continued)

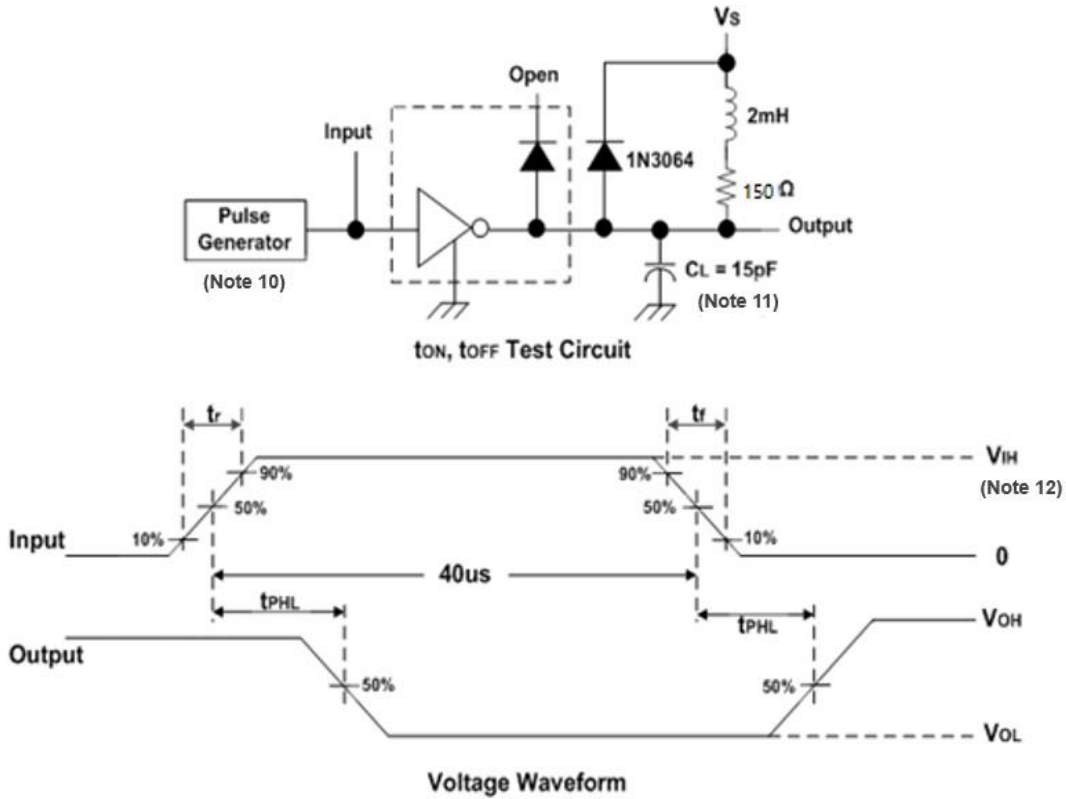
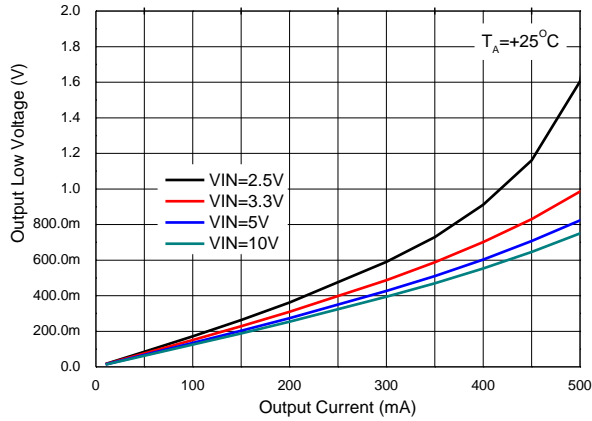

Fig. 8 Latch-Up Test Circuit and Voltage Waveform

- Notes:
- 10. The pulse generator has the following characteristics: pulse width = 40 μ s, duty cycle = 10%, output impedance 50 Ω , $t_r \leq 5$ ns, $t_f \leq 10$ ns.
 - 11. CL includes probe and the test board capacitance.
 - 12. For testing for the ULN62003A, $V_{IH} = 5$ V.

Typical Performance Characteristics

Output Low Voltage vs. Output Sink Current (One Darlington)



MOSFET ON Resistor vs. Output Current

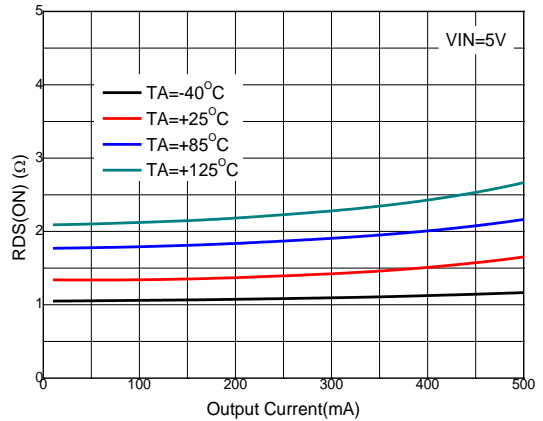

MOSFET ON Resistor vs. Output Current

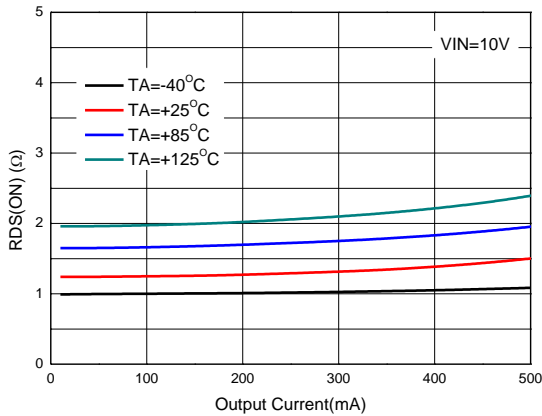

MOSFET ON Resistor vs. Input Voltage

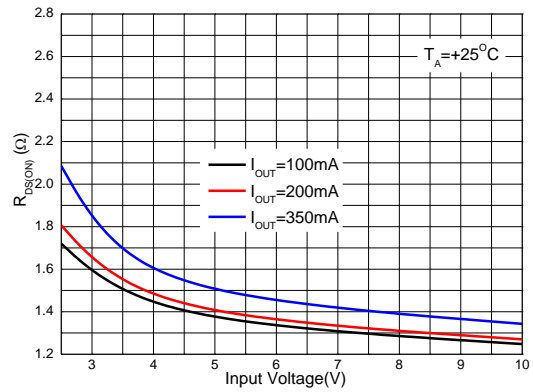

MOSFET ON Resistor vs. Temperature

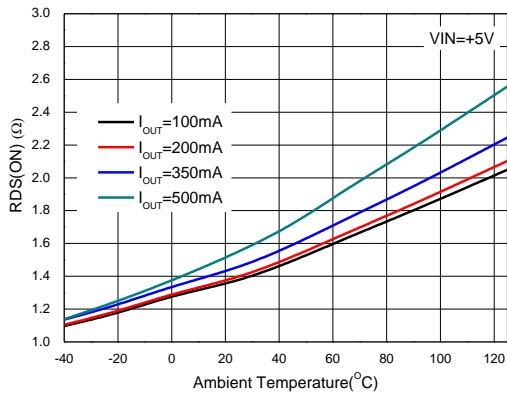

Clamp Diode Forward Voltage vs. Forward Current

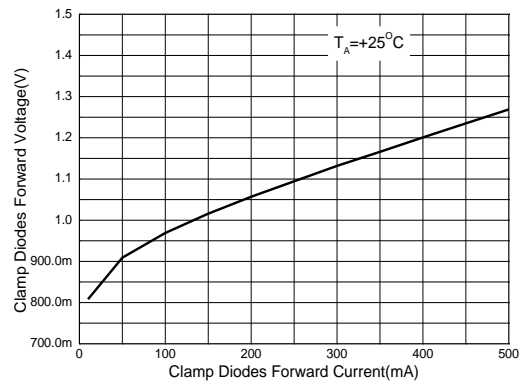

Typical Performance Characteristics (continued)

Input On Voltage vs. Output Current

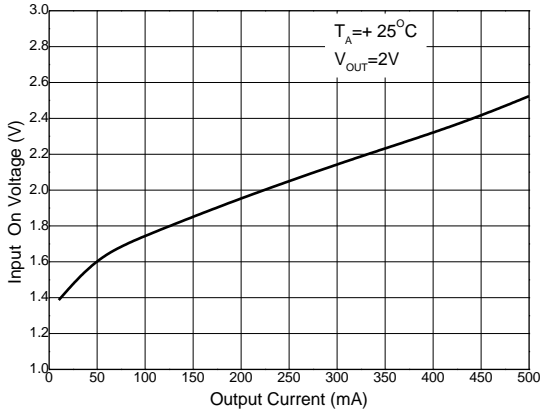

Input On Voltage vs. Temperature

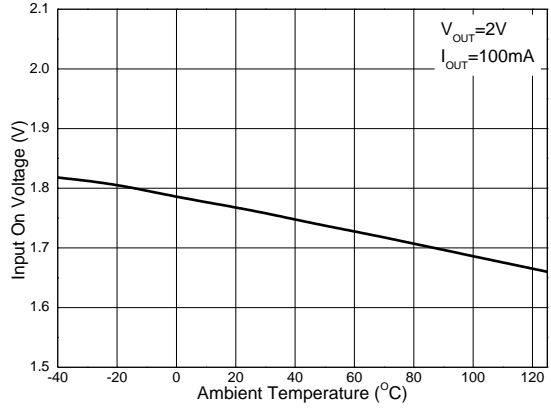

Input On Current vs. Temperature

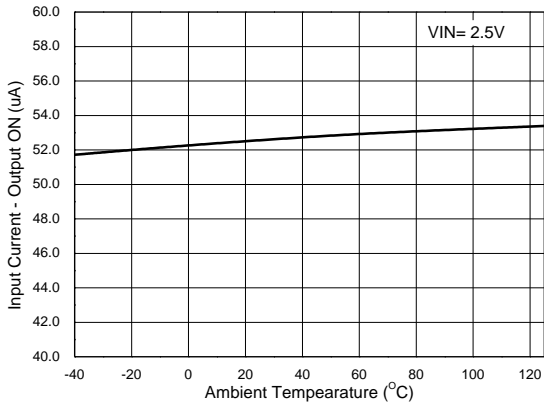

Max. Drain-Source Current vs. Duty Cycle

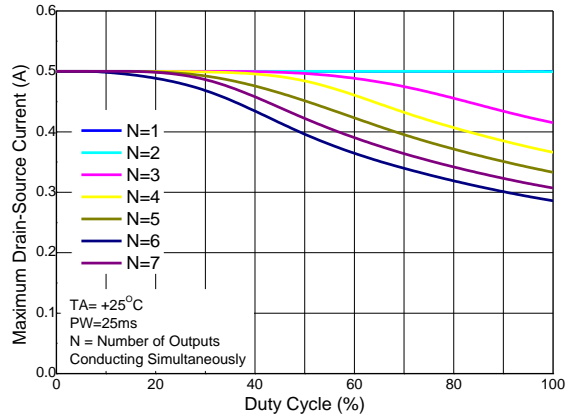

Max. Drain-Source Current vs. Duty Cycle

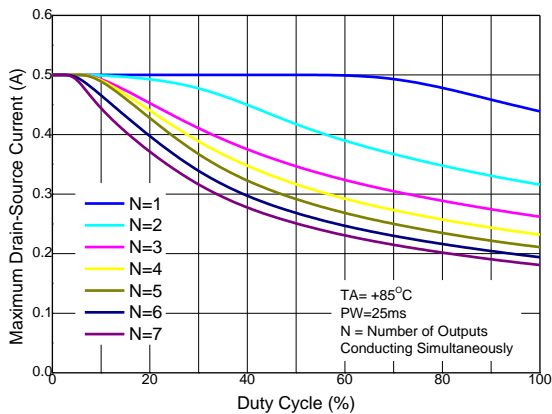

Ordering Information

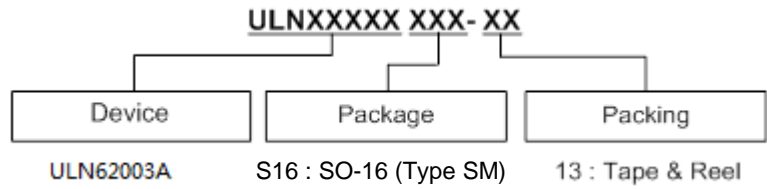

Part Number	Part Number Suffix	Package Code	Package	Packing	
				Qty.	Carrier
ULN62003AS16-13	-13	S16	SO-16 (Type SM)	4,000	13" Tape & Reel

Marking Information

(1) SO-16 (Type SM)

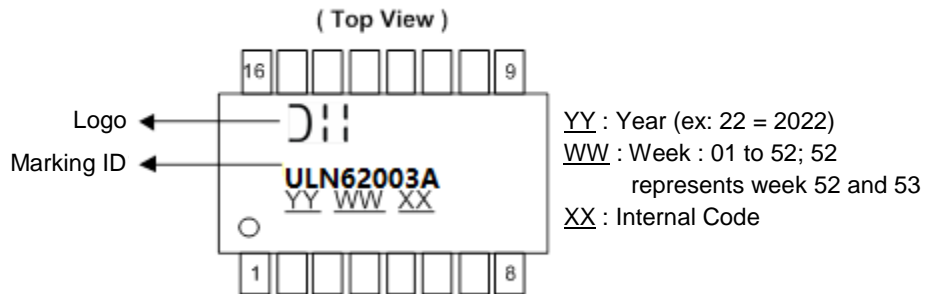

Package Outline Dimensions

Please see <http://www.diodes.com/package-outlines.html> for the latest version.

SO-16 (Type SM)

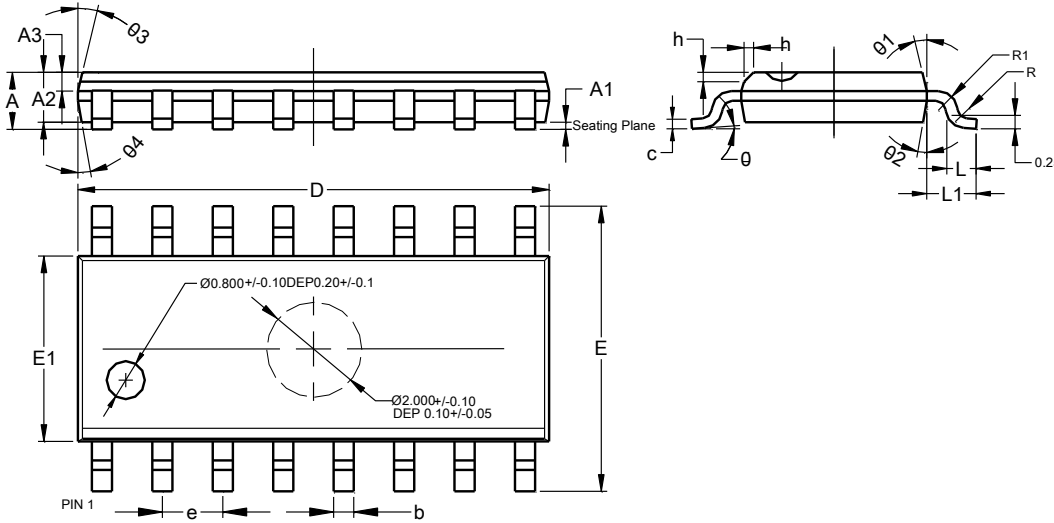

SO-16 (Type SM)			
Dim	Min	Max	Typ
A	1.35	1.75	1.60
A1	0.10	0.25	0.15
A2	1.25	1.65	1.45
A3	0.55	0.75	0.65
b	0.36	0.51	--
c	0.17	0.25	--
D	9.80	10.00	9.90
E	5.80	6.20	6.00
E1	3.80	4.00	3.90
e	1.27BSC		
h	0.30	0.50	0.40
L	0.45	0.80	0.60
L1	1.04REF		
R	0.07	--	--
R1	0.07	--	--
theta	0°	8°	--
theta1	10°	14°	12°
theta2	8°	12°	10°
theta3	10°	14°	12°
theta4	8°	12°	10°
All Dimensions in mm			

Suggested Pad Layout

Please see <http://www.diodes.com/package-outlines.html> for the latest version.

SO-16 (Type SM)

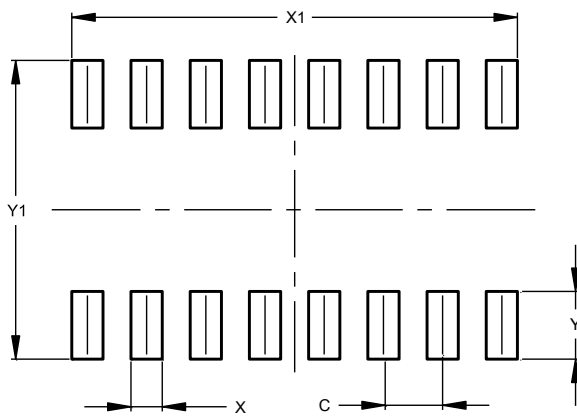

Dimensions	Value (in mm)
C	1.270
X	0.670
X1	9.560
Y	1.450
Y1	6.400

Mechanical Data

- Moisture Sensitivity: Level 3 per J-STD-020
- Terminals: Finish – Matte Tin Plated Leads, Solderable per MIL-STD-202, Method 208 (3)
- Weight: 0.16 grams (Approximate)