

Features

- Eight Darlington transistors per package
- Extended temperature range: -40 to 105 °C
- Output current to 500 mA
- Output voltage to 50 V
- Integral suppression diodes
- Versions for all popular logic families
- Output can be paralleled
- Inputs pinned opposite outputs to simplify board layout

Description

The ULQ2801A-ULQ2804A each contain eight Darlington transistors with common emitters and integral suppression diodes for inductive loads. Each Darlington features a peak load current rating of 600 mA (500 mA continuous) and can withstand at least 50 V in the off state. Outputs may be paralleled for higher current capability.

Five versions are available to simplify interfacing to standard logic families: the ULQ2801A is designed for general purpose applications with a current limit resistor; the ULQ2802A has a 10.5 kΩ input resistor and zener for 14-25 V PMOS; the ULQ2803A has a 2.7 kΩ input resistor for 5 V TTL and CMOS; the ULQ2804A has a 10.5 kΩ input resistor for 6-15 V CMOS.

All types are supplied in a 18-lead plastic DIP with a copper lead from and feature the convenient input-opposite-output pinout to simplify board layout.

Table 1. Device summary

Order codes	Package
ULQ2801A	DIP-18
ULQ2802A	
ULQ2803A	
ULQ2804A	

Contents

1	Diagrams	3
2	Pin configuration	4
3	Maximum ratings	5
4	Electrical characteristics	6
5	Test circuits	7
6	Package mechanical data	10
7	Revision history	12

1 Diagrams

Figure 1. Schematic diagrams

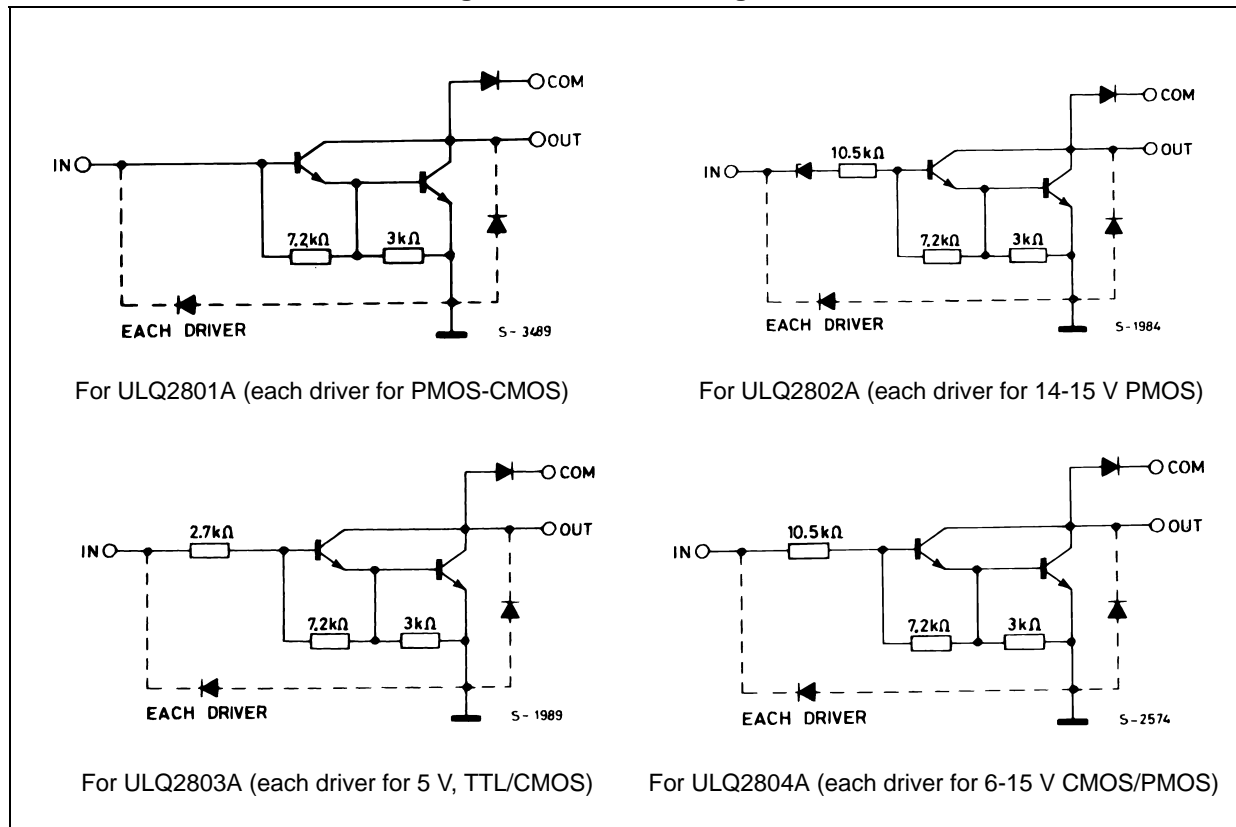

2 Pin configuration

Figure 2. Pin connections (top view)

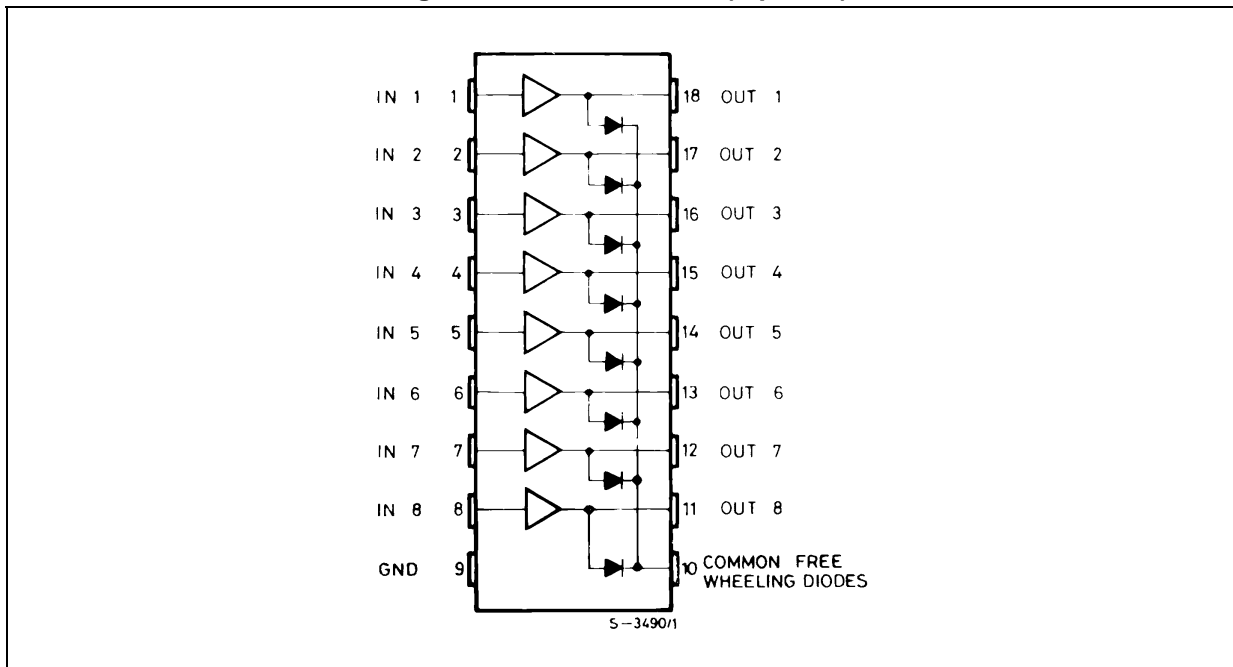

3 Maximum ratings

Table 2. Absolute maximum ratings

Symbol	Parameter	Value	Unit
V_O	Output voltage	50	V
V_I	Input voltage (for ULQ2802A - ULQ2803A - ULQ2804A)	30	V
I_C	Continuous collector current	500	mA
I_B	Continuous base current	25	mA
P_{TOT}	Power dissipation (one Darlington pair)	1	W
	Power dissipation (total package)	2.25	
T_A	Operating ambient temperature range	- 40 to 85	°C
T_{STG}	Storage temperature range	- 55 to 150	°C

Table 3. Thermal data

Symbol	Parameter	Value	Unit
R_{thJA}	Thermal resistance junction-ambient, Max.	55	°C/W

4 Electrical characteristics

$T_A = 25\text{ °C}$ unless otherwise specified.

Table 4. Electrical characteristics

Symbol	Parameter	Test condition	Min.	Typ.	Max.	Unit
I_{CEX}	Output leakage current	$V_{CE} = 50\text{ V}$, (Figure 7)			50	μA
		$T_A = 105\text{ °C}$, $V_{CE} = 50\text{ V}$ (Figure 7)			100	
		$T_A = 105\text{ °C}$ for ULQ2802A, $V_{CE} = 50\text{ V}$, $V_I = 6\text{ V}$ (Figure 8)			500	
		$T_A = 105\text{ °C}$ for ULQ2804A, $V_{CE} = 50\text{ V}$, $V_I = 1\text{ V}$ (Figure 8)			500	
$V_{CE(SAT)}$	Collector-emitter saturation voltage (Figure 9)	$I_C = 100\text{ mA}$, $I_B = 250\text{ }\mu\text{A}$		0.9	1.1	V
		$I_C = 200\text{ mA}$, $I_B = 350\text{ }\mu\text{A}$		1.1	1.3	
		$I_C = 350\text{ mA}$, $I_B = 500\text{ }\mu\text{A}$		1.3	1.6	
$I_{I(ON)}$	Input current (Figure 6)	for ULQ2802A, $V_I = 17\text{ V}$		0.82	1.25	mA
		for ULQ2803A, $V_I = 3.85\text{ V}$		0.93	1.35	
		for ULQ2804A, $V_I = 5\text{ V}$		0.35	0.5	
		$V_I = 12\text{ V}$		1	1.45	
$I_{I(OFF)}$	Input current (Figure 7)	$T_A = 105\text{ °C}$, $I_C = 500\text{ }\mu\text{A}$	50	65		μA
$V_{I(ON)}$	Input voltage (Figure 8)	$V_{CE} = 2\text{ V}$, for ULQ2802A			13	V
		$I_C = 300\text{ mA}$				
		for ULQ2803A				
		$I_C = 200\text{ mA}$			2.4	
		$I_C = 250\text{ mA}$			2.7	
		$I_C = 300\text{ mA}$			3	
		for ULQ2804A				
		$I_C = 125\text{ mA}$			5	
$I_C = 200\text{ mA}$			6			
$I_C = 275\text{ mA}$			7			
$I_C = 350\text{ mA}$			8			
h_{FE}	DC forward current gain (Figure 5)	for ULQ2801A, $V_{CE} = 2\text{ V}$, $I_C = 350\text{ mA}$	1000			
C_I	Input capacitance			15	25 ⁽¹⁾	pF
t_{PLH}	Turn-on delay time	0.5 V_I to 0.5 V_O		0.25	1 ⁽¹⁾	μs
t_{PHL}	Turn-off delay time	0.5 V_I to 0.5 V_O		0.25	1 ⁽¹⁾	μs
I_R	Clamp diode leakage current (Figure 9)	$V_R = 50\text{ V}$			50	μA
		$T_A = 105\text{ °C}$, $V_R = 50\text{ V}$			100	
V_F	Clamp diode forward voltage (Figure 10)	$I_F = 350\text{ mA}$		1.7	2	V

1. Guaranteed by design.

5 Test circuits

Figure 3. Output leakage current

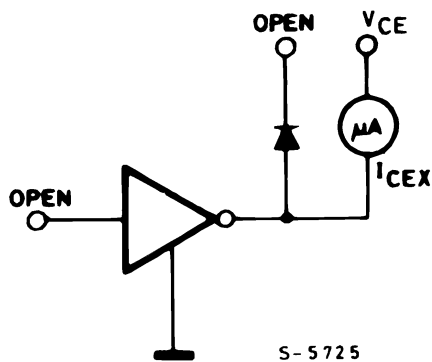

Figure 4. Output leakage current

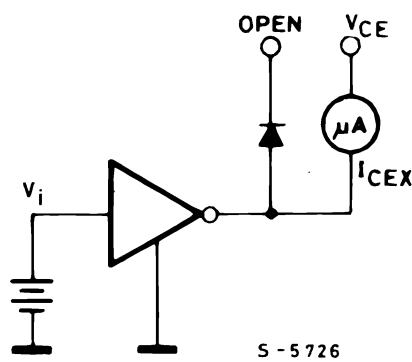

Figure 5. Collector-emitter saturation voltage

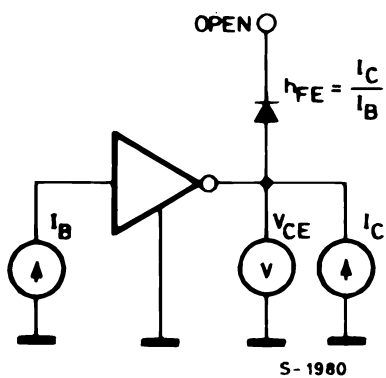

Figure 6. Input current (ON)

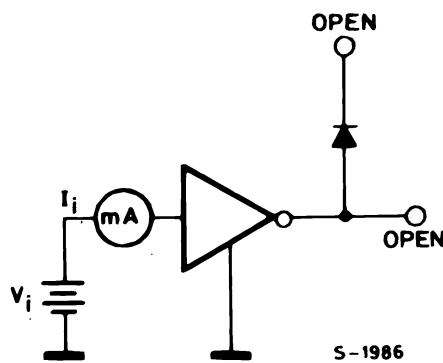

Figure 7. Input current (OFF)

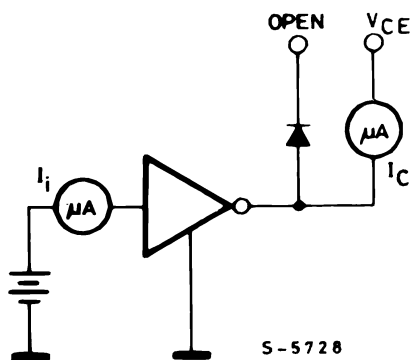
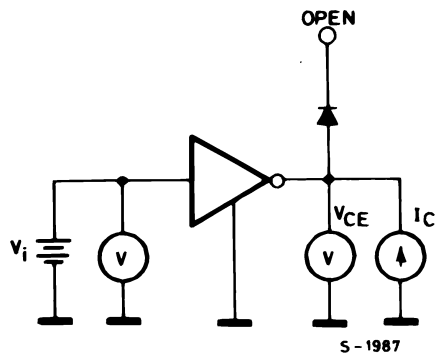

Figure 8. Input voltage



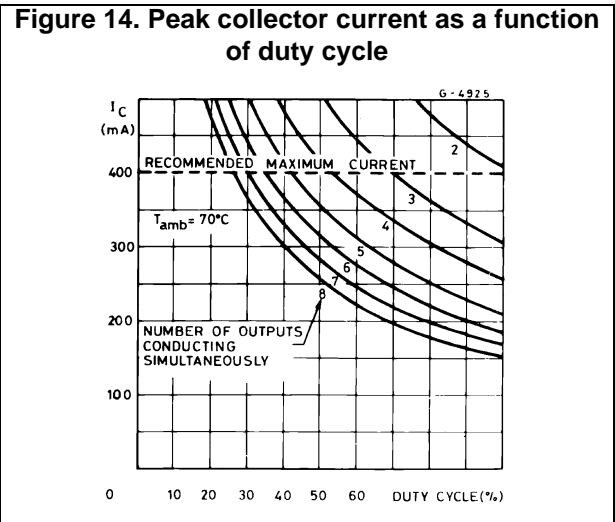
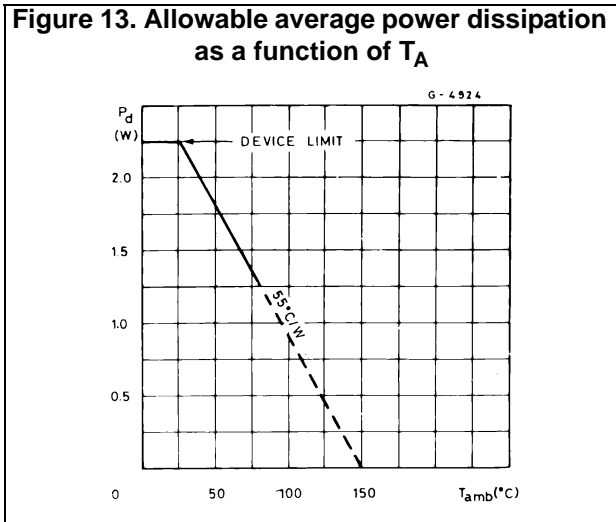
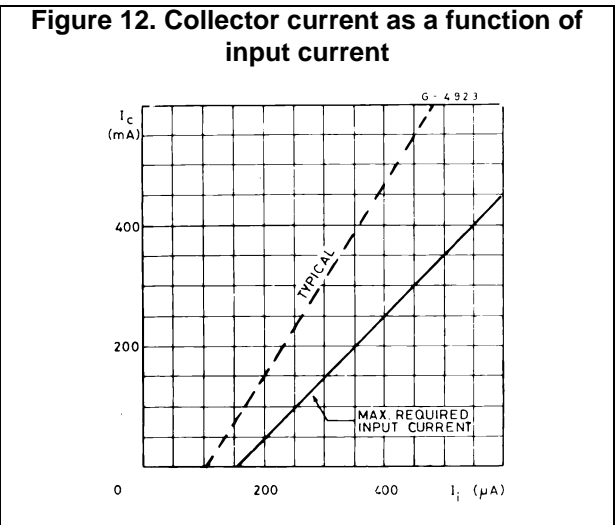
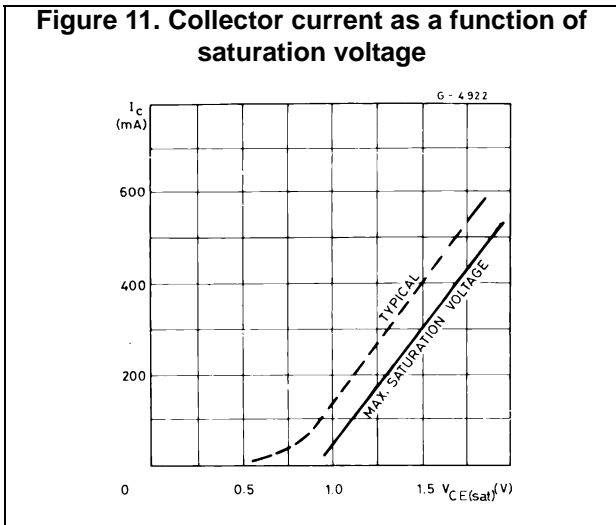
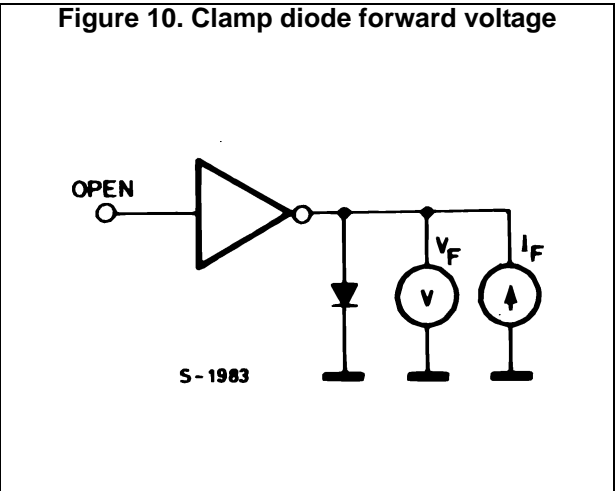
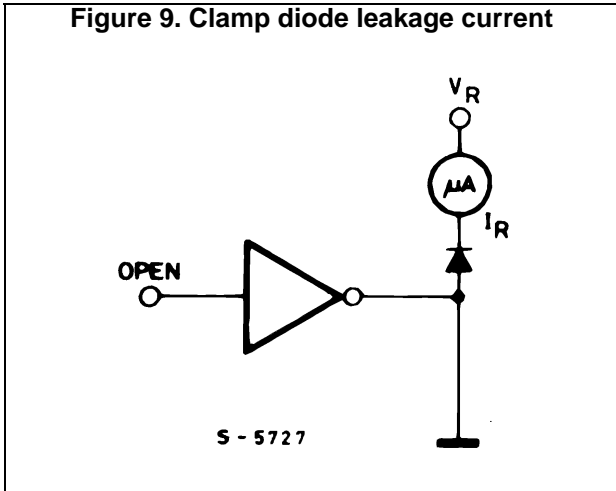

Figure 15. Peak collector current as a function of duty

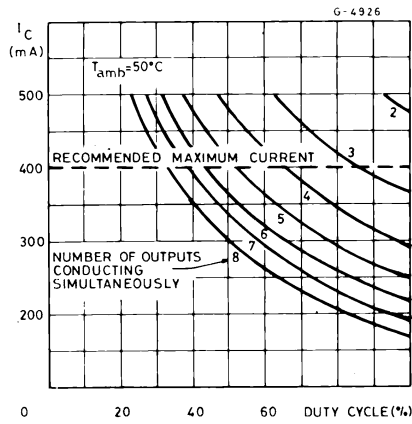

Figure 16. Input current as a function of input voltage (for ULQ2802A)

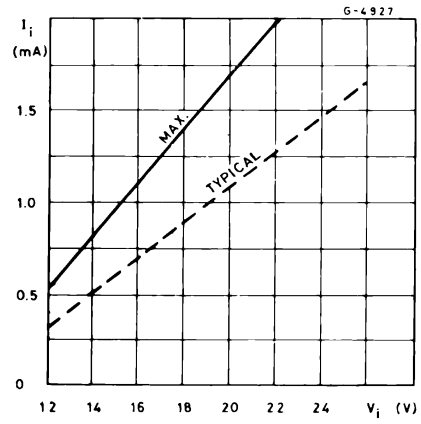

Figure 17. Input current as a function of input voltage (for ULQ2804A)

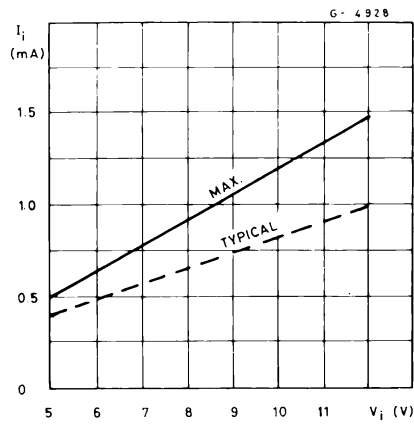
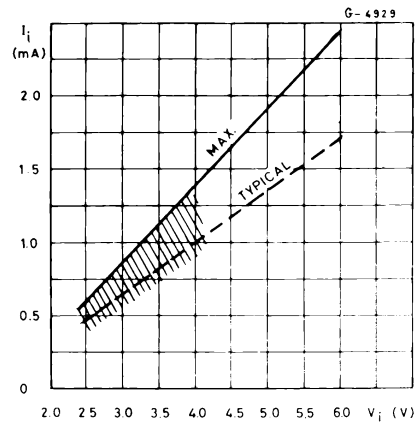

Figure 18. Input current as a function of input voltage (for ULQ2803A)



6 Package mechanical data

In order to meet environmental requirements, ST offers these devices in different grades of ECOPACK[®] packages, depending on their level of environmental compliance. ECOPACK[®] specifications, grade definitions and product status are available at: www.st.com. ECOPACK[®] is an ST trademark.

DIM.	mm			inch		
	MIN.	TYP.	MAX.	MIN.	TYP.	MAX.
a1	0.254			0.010		
B	1.39		1.65	0.055		0.065
b		0.46			0.018	
b1		0.25			0.010	
D			23.24			0.915
E		8.5			0.335	
e		2.54			0.100	
e3		20.32			0.800	
F			7.1			0.280
I			3.93			0.155
L		3.3			0.130	
Z		1.27	1.59		0.050	0.063

OUTLINE AND MECHANICAL DATA

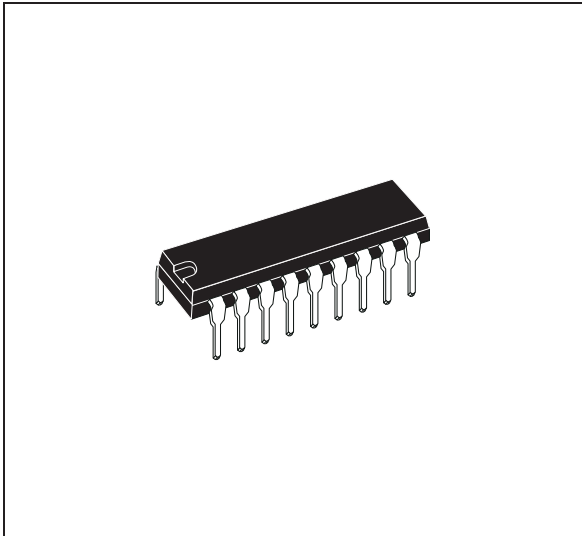

DIP18

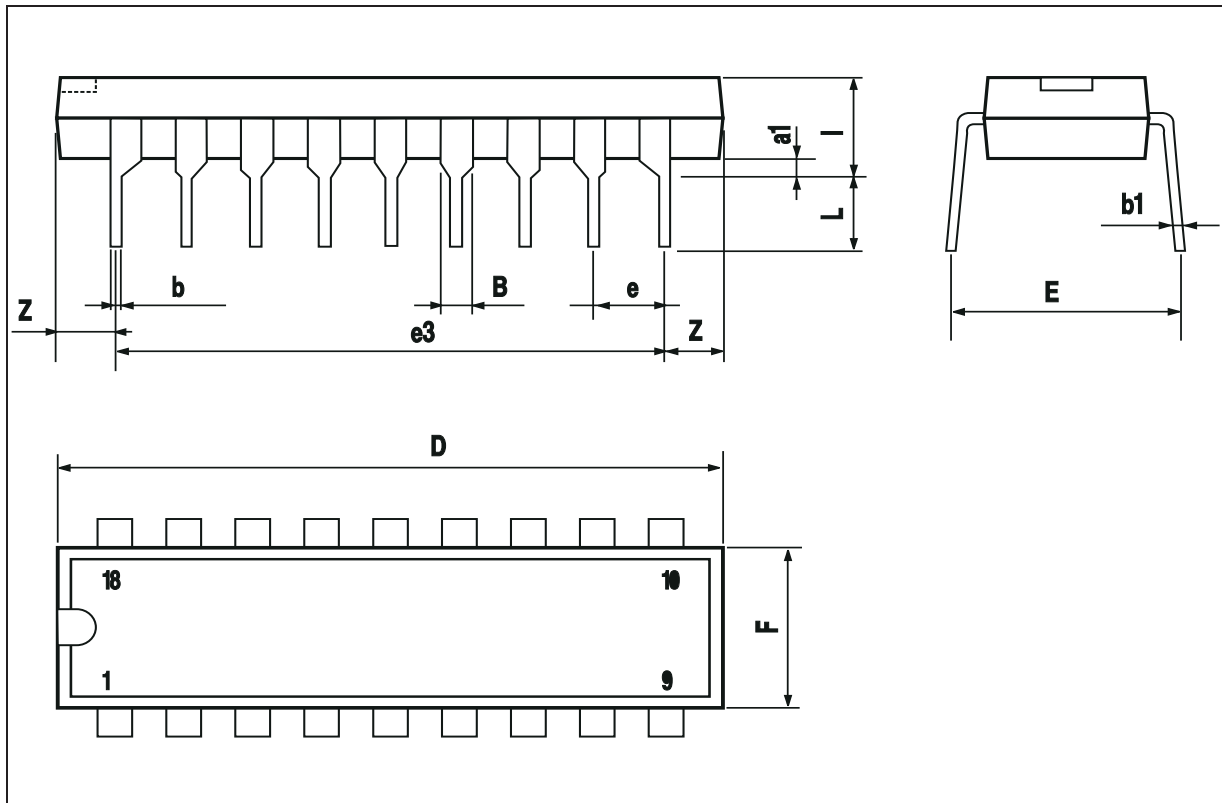

7 Revision history

Table 5. Document revision history

Date	Revision	Changes
19-Sep-2003	1	First issue.
25-Jun-2008	2	Added: Table 1 on page 1.
27-Jun-2018	3	Updated: $I_{I(ON)}$ test condition in Table 4: Electrical characteristics .