

μPC177, 339

R03DS0139EJ0100

Rev.1.10

2020.05.12

Single Power Supply Quad Comparator

DESCRIPTION

μPC177, μPC339 comparators are designed for single power supply operation. The features include low-voltage operation, common-mode input voltage range from V-(GND) level, open-collector output and low current consumption. Furthermore, these products can operate with both power supplies and can be widely used for various voltage comparison application.

Depending on the usage and operating ambient temperature range, the μPC177 is design for communication industries and μPC339 is design for general purposes.

Along with this series of lineup, the dual type comparators, μPC277 and 393 with the same circuit configuration are also available.

FEATURES

- Input Offset Voltage ±2 mV (TYP.)
- Input Bias Current 25 nA (TYP.)
- Voltage Gain 1.3 μs (TYP.)
- Pulse Response Time 16 mA (TYP.)
- A wired OR is possible as the output is an open collector
- Low Voltage Operation V⁺ - V⁻ : 2 ~ 32 V

ORDERING INFORMATION

Order Name	Selected Grade	Package
μPC177G2-A	Standard	14-pin plastic SOP (5.72 mm (225))
μPC339G2-A	Standard	14-pin plastic SOP (5.72 mm (225))

EQUIVALENT CIRCUIT (1/4 Circuit)

PIN CONFIGURATION (Top View)

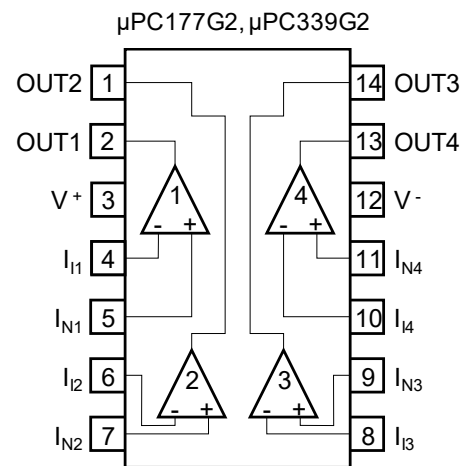
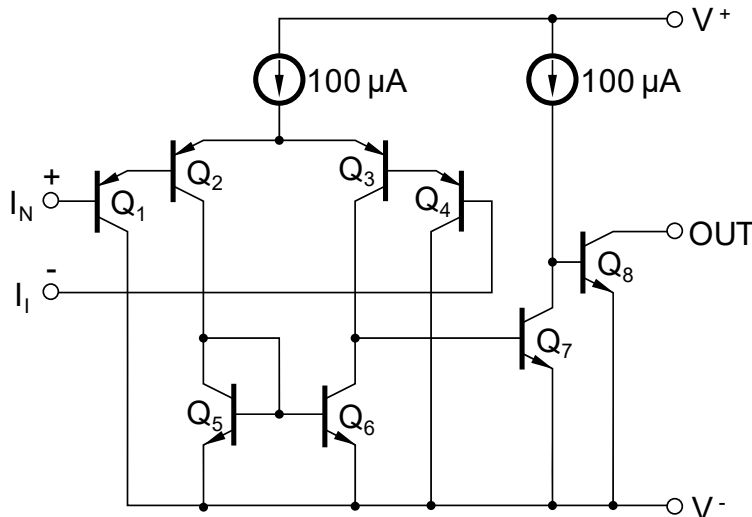

ABSOLUTE MAXIMUM RATINGS (T_A = 25 °C)

Parameter	Symbol	μPC177G2	μPC339G2	Unit
Power Supply Voltage ^{Note 1}	V ⁺ - V ⁻	-0.3 ~ +36		V
Differential Input Voltage	V _{ID}	±36		V
Input Voltage ^{Note 2}	V _I	V ⁻ -0.3 ~ V ⁻ +36		V
Output Voltage ^{Note 3}	V _O	V ⁻ -0.3 ~ V ⁻ +36		V
Total Power Dissipation ^{Note 4}	P _T	550		mW
Output Short Circuit Duration (vs. GND) ^{Note 5}	t _s	Indefinite		s
Operating Ambient Temperature	T _A	-40 ~ +85	-20 ~ +80	°C
Storage Temperature	T _{stg}	-55 ~ +125		°C

[Note] 1. Note that reverse connections of the power supply may damage the ICs.

2. This is the input voltage range that can be applied to the input terminal without any characteristics degradation or breakdown. It can be applied regardless of the supply voltage. Do not apply the voltage below V⁻(GND)-0.3V. The comparator electrical characteristics will operate normally when the input voltage is operating within the common-mode input voltage range.
3. Voltage range that can be applied externally to the output terminal without deteriorating or damage to the product. It can be applied regardless of the power supply. Caution not to exceed the ratings, including transient conditions such as when the power supply is ON/OFF.
4. Power dissipation value when T_A ≤ +25 °C. For T_A > 25 °C, de-rate at -5.5 mW/°C
5. A short circuit to the V⁺ side may destroy the IC. Please use the total loss and de-rating value from Note 4.

RECOMMENDED OPERATING CONDITIONS

Parameter	Symbol	MIN.	TYP.	MAX.	Unit
Power Supply Voltage (Dual Supply)	V^\pm	± 1		± 16	V
Power Supply Voltage ($V^- = \text{GND}$)	V^+	+2		+32	V

ELECTRICAL CHARACTERISTICS

μPC177G2, μPC339G2 ($T_A = 25\text{ }^\circ\text{C}$, $V^+ = +5\text{ V}$, $V^- = \text{GND}$)

PARAMETER	SYMBOL	MIN.	TYP.	MAX.	UNIT	TEST CONDITION
Input Offset Voltage	V_{IO}		± 2	± 5	mV	$V_O = 1.4\text{ V}$, $V_{REF} = 1.4\text{ V}$, $R_S = 0\ \Omega$
Input Offset Current	I_{IO}		± 5	± 50	nA	$V_O \doteq 1.4\text{ V}$
Input Bias Current ^{Note 6}	I_B		25	250	nA	$V_O \doteq 1.4\text{ V}$
Large Signal Voltage Gain	A_v		200000			$R_L = 15\text{ k}\Omega$
Circuit Current ^{Note 7}	I_{CC}		0.8	2	mA	$R_L = \infty$, $I_O = 0\text{ A}$
Common Mode Input Voltage Range	V_{ICM}	0		$V^+ - 1.5$	V	
Output Saturation Voltage	V_{OL}		0.2	0.4	V	$V_{IN(-)} = 1\text{ V}$, $V_{IN(+)} = 0\text{ V}$, $I_{O\text{ SINK}} = 4\text{ mA}$
Output Sink Current	$I_{O\text{ SINK}}$	6	16		mA	$V_{IN(-)} = 1\text{ V}$, $V_{IN(+)} = 0\text{ V}$, $V_O \leq 1.5\text{ V}$
Output Leakage Current	$I_{O\text{ LEAK}}$		0.1		nA	$V_{IN(+)} = 1\text{ V}$, $V_{IN(-)} = 0\text{ V}$, $V_O = 5\text{ V}$
Pulse Response Time ^{Note 8}			1.3		μs	$R_L = 5.1\text{ k}\Omega$, $V_{RL} = 5\text{ V}$

TYPICAL APPLICATION CIRCUIT EXAMPLE

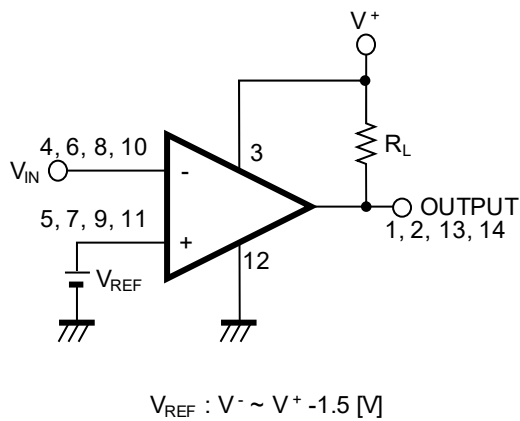

Comparator with Hysteresis

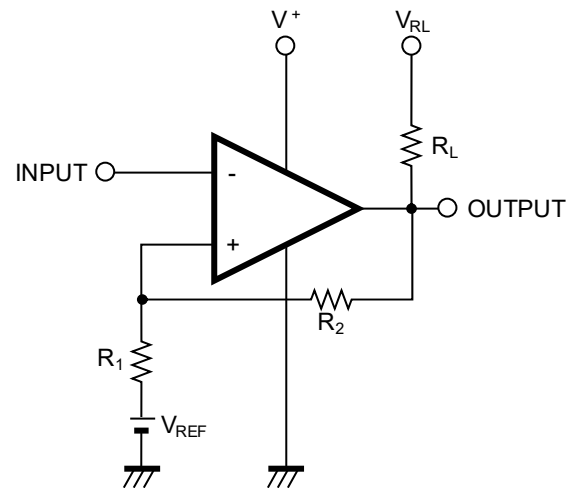

• Threshold Voltage

$$V_{TH(High)} \doteq V_{REF} + \frac{R_1}{R_L + R_2 + R_1} (V_{RL} - V_{REF})$$

$$V_{TH(Low)} \doteq V_{REF} - \frac{R_1}{R_1 + R_2} (V_{REF} - V_{OL})$$

$$(V_{RL} > V_{REF} > V_{OL})$$

ELECTRICAL CHARACTERISTICS CURVE (T_A = 25 °C, TYP.) (Reference Value)

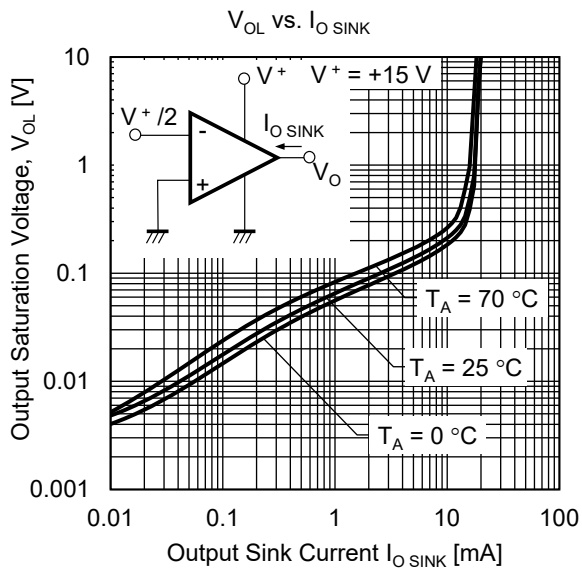
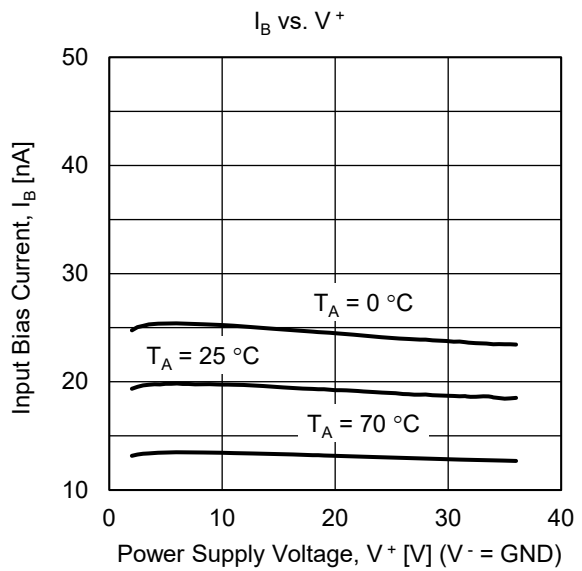
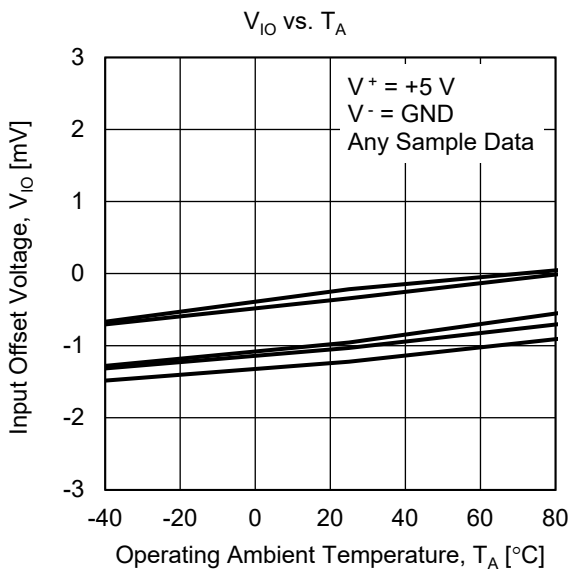
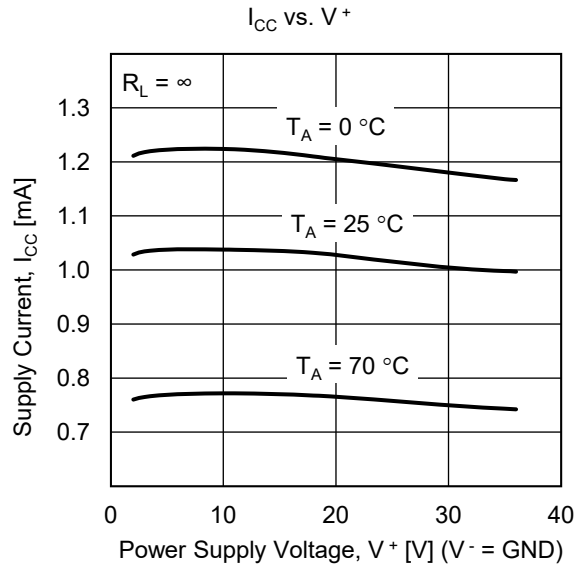
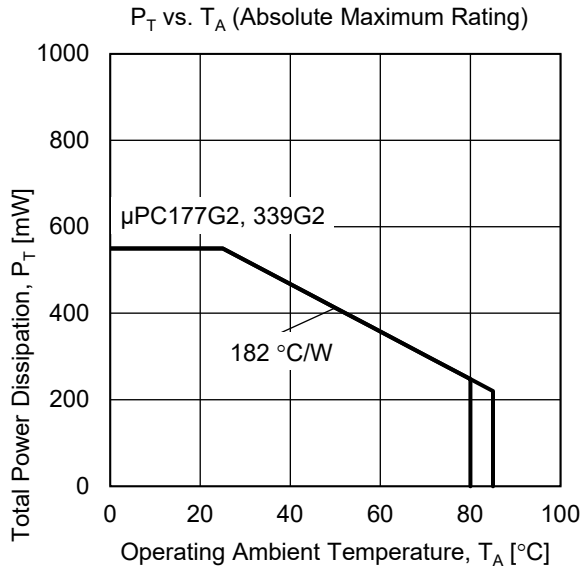

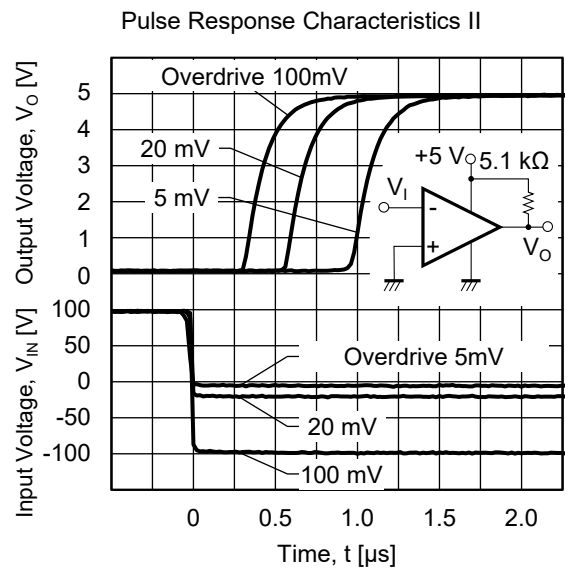
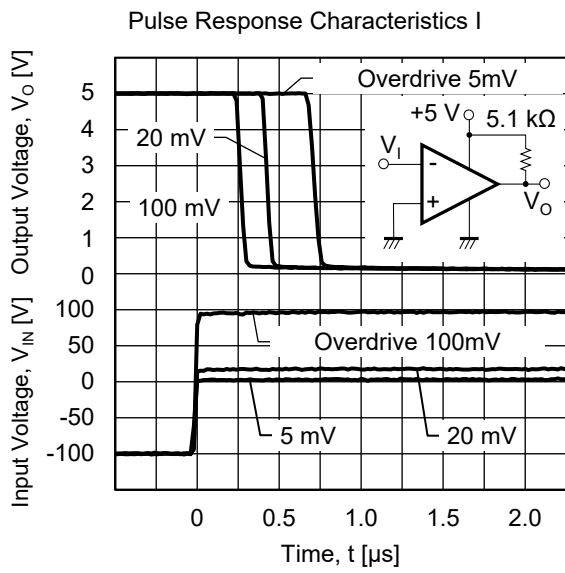

USE WITH PRECAUTIONS

- **Managing unused circuits**

If there is an unused circuit, the following connection is recommended.

Example of unused circuit process

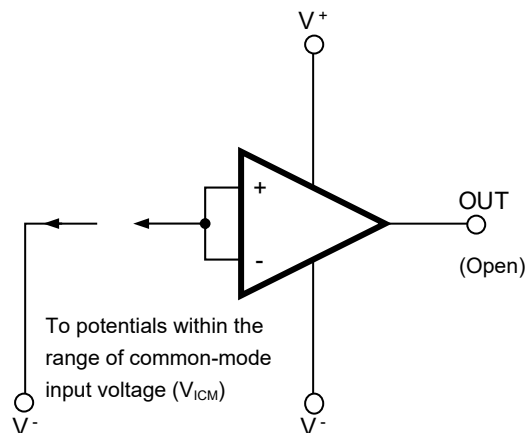

- **Ratings of input/output pin voltage**

When the voltage of input/output pin exceeds the absolute maximum rating, the parasitic diode within the IC may conduct, causing characteristics degradation or damage. In addition, if the input pin is lower than V⁻, or the output pin exceeds the power supply voltage, it is recommended to make a clamping circuit using a diode with low forward voltage (e.g.: Schottky diode) as protection.

- **Range of common-mode input voltage**

When the supply voltage does not meet the condition of electrical characteristics, the range of common-mode input voltage is as follows.

$$V_{ICM} \text{ (TYP.)}: V^- \sim V^+ - 1.5 \text{ [V]} \text{ (} T_A = 25 \text{ } ^\circ\text{C)}$$

During designing, do include some tolerance by considering temperature characteristics etc.

- **Regarding Input Current**

The Input Bias Current [I_B] specified in the electrical characteristics table, is the average value of current flowing through the +input terminal [I_N] and the current flowing through the -input terminal [I_P] in the balanced state of the differential amplifier circuit of the input stage (with negative feedback).

Therefore, since the differential amplifier circuit of the input stage is not balanced during comparison operation (in the case of comparator operation), the input current flows twice as much towards the low potential terminal.

- **Handling of ICs**

When stress is added to the ICs due to warpage or bending of a board, the characteristic may fluctuates due to piezoelectric (piezo) effect. Therefore, pay attention to warpage or bending of a board.

PACKAGE DRAWINGS

14-PIN PLASTIC SOP

JEITA Package code	RENESAS code	Previous code	MASS (TYP.) [g]
P-SOP14-0225-1.27	PRSP0014DI-A	P14GR-50-225B	0.14

Unit : mm

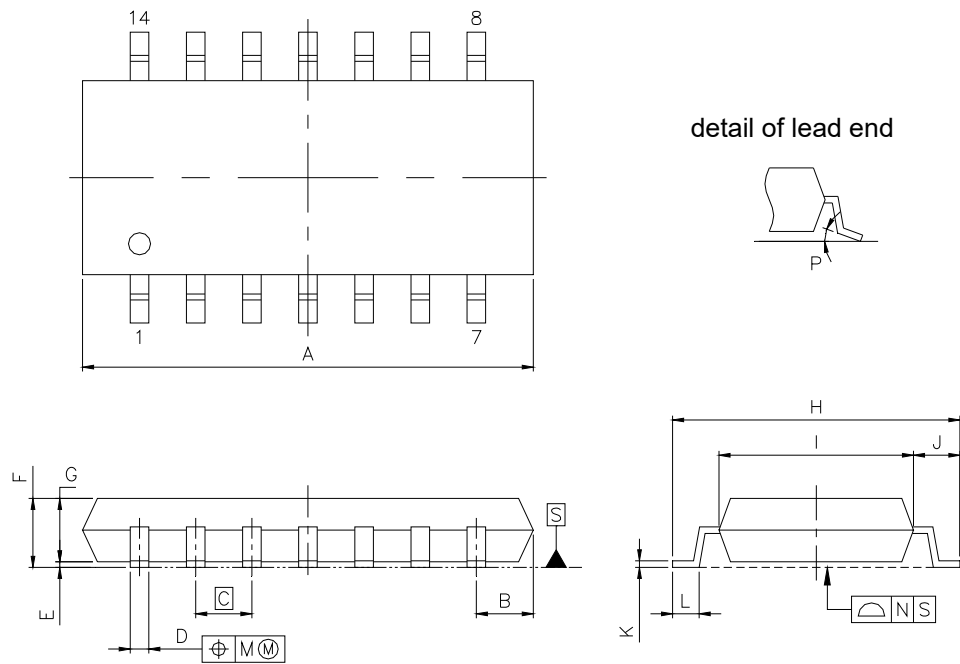

NOTE

Each lead centerline is located within 0.12 mm of its true position (T.P.) at maximum material condition.

ITEM	MILLIMETERS
A	10.2 ±0.26
B	1.42 MAX
C	1.27 (T.P)
D	0.42 ^{+0.08} / _{-0.07}
E	0.1 ±0.1
F	1.59 ^{+0.21} / _{-0.2}
G	1.49
H	6.5 ±0.2
I	4.4 ±0.1
J	1.1 ±0.16
K	0.17 ^{+0.08} / _{-0.07}
L	0.6 ±0.2
M	0.1
N	0.10
P	3° ^{+7°} / _{-3°}