

# μPC177GR-9LG, μPC339GR-9LG

R03DS0140EJ0100

Rev.1.10

## Single Power Supply Quad Comparator

2020.05.12

### DESCRIPTION

μPC177GR-9LG, μPC339GR-9LG comparators are designed for single power supply operation. The features include low-voltage operation, common-mode input voltage range from V-(GND) level, open-collector output and low current consumption. Furthermore, these products can operate with both power supplies and can be widely used for various voltage comparison application.

Depending on the usage and operating ambient temperature range, the μPC177GR-9LG is design for extended temperature and μPC339GR-9LG is design for general purposes.

Along with this series of lineup are dual type comparators, μPC277GR-9LG, μPC277MP-KAA, and μPC393GR-9LG with the same circuit configuration are also available.

### FEATURES

- Input Offset Voltage ±1 mV (TYP.)
- Input Bias Current 20 nA (TYP.)
- Voltage Gain 200000 (TYP.)
- Pulse Response Time 1.6 μs (TYP.)
- Output Sink Current 16 mA (TYP.)
- A wired OR is possible as the output is an open collector
- Low Voltage Operation V<sup>+</sup> - V<sup>-</sup> : +2 ~ +32 V
- Small Package (Half the footprint size of 14-pin plastic SOP ( 1.27 mm pitch))

### ORDERING INFORMATION

Order Name	Selected Grade	Package
μPC177GR-9LG-A	Standard	14-pin plastic TSSOP ( 5.72 mm ( 225 ) )
μPC339GR-9LG-A	Standard	14-pin plastic TSSOP ( 5.72 mm ( 225 ) )

**EQUIVALENT CIRCUIT (1/4 Circuit)**

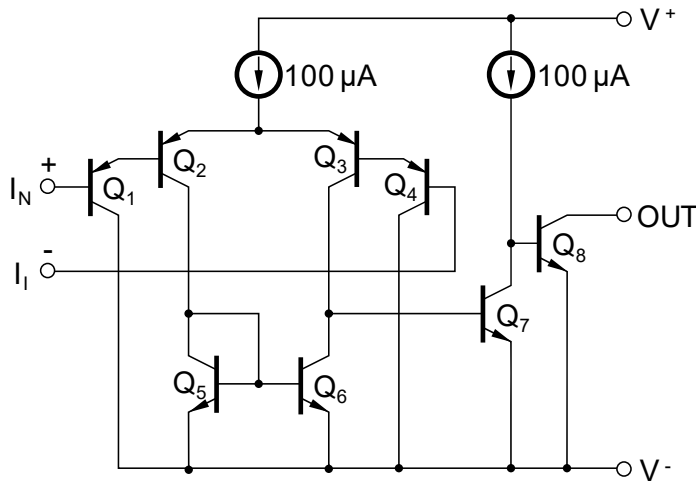

**PIN CONFIGURATION (Marking side)**

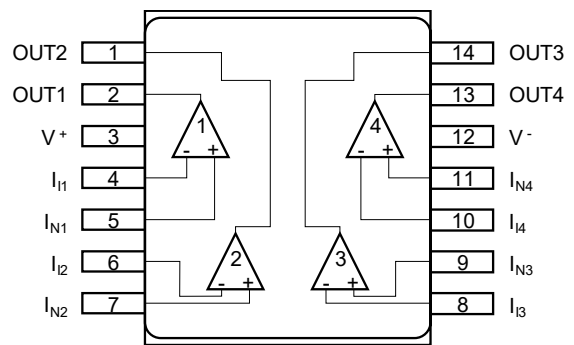

**ABSOLUTE MAXIMUM RATINGS (T<sub>A</sub> = 25 °C)**

Parameter	Symbol	μPC177GR-9LG	μPC339GR-9LG	Unit
Power Supply Voltage <sup>Note 1</sup>	V <sup>+</sup> - V <sup>-</sup>	-0.3 ~ +36		V
Differential Input Voltage	V <sub>ID</sub>	±36		V
Input Voltage <sup>Note 2</sup>	V <sub>I</sub>	V <sup>-</sup> -0.3 ~ V <sup>-</sup> +36		V
Output Voltage <sup>Note 3</sup>	V <sub>O</sub>	V <sup>-</sup> -0.3 ~ V <sup>-</sup> +36		V
Total Power <sup>Note 4</sup>	P <sub>T</sub>	550		mW
Output Short Circuit Duration (vs. GND) <sup>Note 5</sup>	t <sub>s</sub>	Indefinite		s
Operating Ambient Temperature	T <sub>A</sub>	-40 ~ +125	-40 ~ +85	°C
Storage Temperature	T <sub>stg</sub>	-55 ~ +150	-55 ~ +125	°C

- 【Note】**
- Note that reverse connections of the power supply may damage the ICs.
  - This is the input voltage range that can be applied to the input terminal without any characteristics degradation or breakdown. It can be applied regardless of the supply voltage. Do not apply the voltage below V-(GND)-0.3V. The comparator electrical characteristics will operate normally when the input voltage is operating within the common-mode input voltage range.
  - Voltage range that can be applied externally to the output terminal without deteriorating or damage to the product. It can be applied regardless of the power supply. Caution not to exceed the ratings, including transient conditions such as when the power supply is ON/OFF.
  - This is the value when mounting the glass epoxy board (size 100 mm x 100 mm, thickness 1 mm, and copper foil only on one side with 15% solid wiring of the board area). Please take note that depending on the operating ambient temperature, each product following conditions and de-rating rate as below:  
 μPC177GR-9LG : For T<sub>A</sub> > 71 °C, de-rate at -7.0 mW/°C  
 (Junction-Ambient Thermal Resistance, R<sub>th(J-A)</sub> = 144 °C/W)  
 μPC339GR-9LG : For T<sub>A</sub> > 46 °C, de-rate at -7.0 mW/°C  
 (Junction-Ambient Thermal Resistance, R<sub>th(J-A)</sub> = 144 °C/W)
  - A short circuit to the V+ side may destroy the IC. Please use the total loss and de-rating value from Note 4.

## RECOMMENDED OPERATING CONDITIONS

Parameter	Symbol	MIN.	TYP.	MAX.	Unit
Power Supply Voltage (Dual Supply)	V±	±1		±16	V
Power Supply Voltage (V <sup>-</sup> = GND)	V <sup>+</sup>	+2		+32	V

## ELECTRICAL CHARACTERISTICS

μPC177GR-9LG, μPC339GR-9LG (T<sub>A</sub> = 25 °C, V<sup>+</sup> = +5 V, V<sup>-</sup> = GND)

PARAMETER	SYMBOL	MIN.	TYP.	MAX.	UNIT	TEST CONDITION
Input Offset Voltage	V <sub>IO</sub>		±1	±5	mV	V <sub>O</sub> = 1.4 V, V <sub>REF</sub> = 1.4 V, R <sub>S</sub> = 0 Ω
Input Offset Current	I <sub>IO</sub>		±5	±50	nA	V <sub>O</sub> = 1.4 V
Input Bias Current <sup>Note 6</sup>	I <sub>B</sub>		20	250	nA	V <sub>O</sub> = 1.4 V
Large Signal Voltage Gain	A <sub>V</sub>		200000			R <sub>L</sub> = 15 kΩ
Circuit Current <sup>Note 7</sup>	I <sub>CC</sub>		1.1	2	mA	R <sub>L</sub> = ∞, I <sub>O</sub> = 0 A
Common Mode Input Voltage Range	V <sub>ICM</sub>	0		V <sup>+</sup> -1.5	V	
Output Saturation Voltage	V <sub>OL</sub>		0.2	0.4	V	V <sub>IN(-)</sub> = 1 V, V <sub>IN(+)</sub> = 0 V, I <sub>O SINK</sub> = 4 mA
Output Sink Current	I <sub>O SINK</sub>	6	16		mA	V <sub>IN(-)</sub> = 1 V, V <sub>IN(+)</sub> = 0 V, V <sub>O</sub> ≤ 1.5 V
Output Leakage Current	I <sub>O LEAK</sub>		0.1		nA	V <sub>IN(+)</sub> = 1 V, V <sub>IN(-)</sub> = 0 V, V <sub>O</sub> = 5 V
Pulse Response Time <sup>Note 8</sup>			1.6		μs	R <sub>L</sub> = 5.1 kΩ, V <sub>RL</sub> = 5 V

## TYPICAL APPLICATION CIRCUIT EXAMPLE

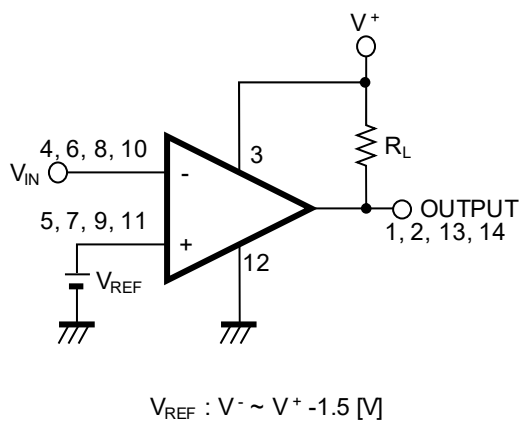

### Comparator with Hysteresis

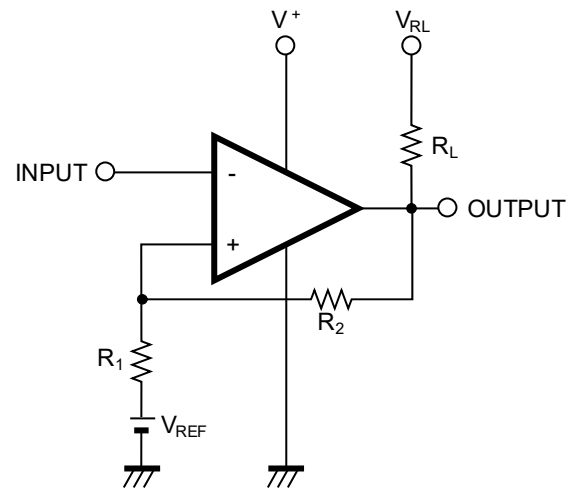

- Threshold Voltage

$$V_{TH (High)} \doteq V_{REF} + \frac{R_1}{R_L + R_2 + R_1} (V_{RL} - V_{REF})$$

$$V_{TH (Low)} \doteq V_{REF} - \frac{R_1}{R_1 + R_2} (V_{REF} - V_{OL})$$

$$(V_{RL} > V_{REF} > V_{OL})$$

**ELECTRICAL CHARACTERISTICS CURVE (T<sub>A</sub> = 25 °C, TYP.) (Reference Value)**

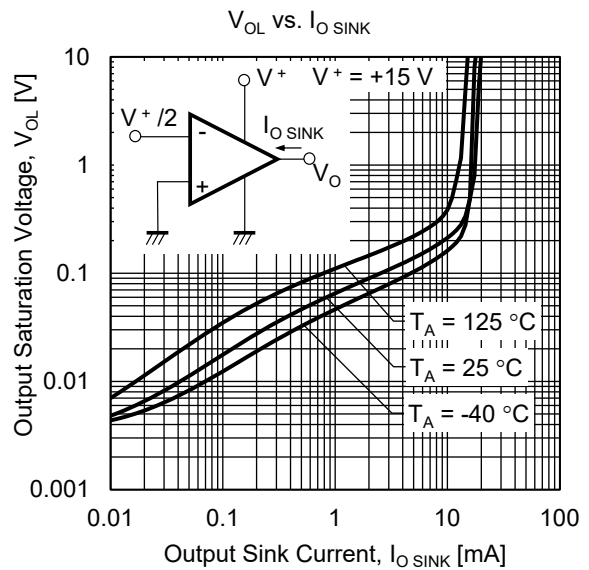
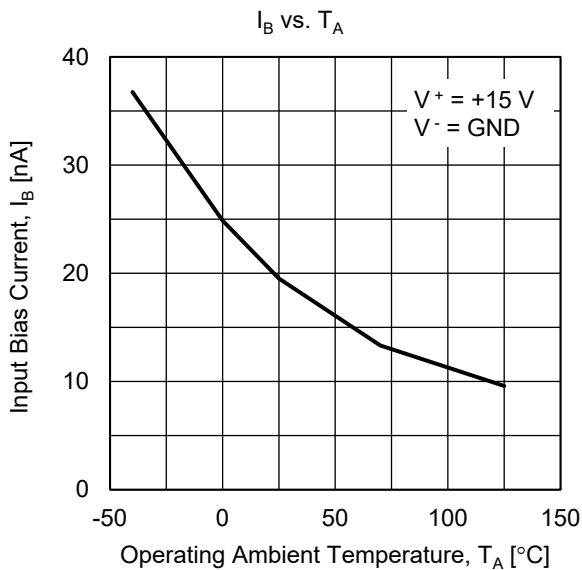
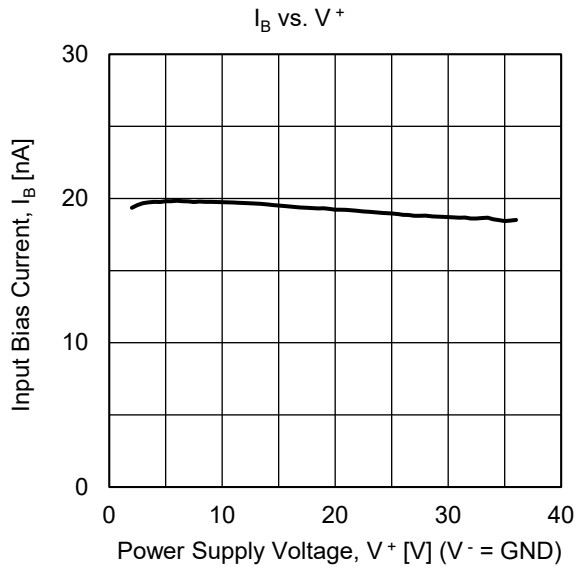
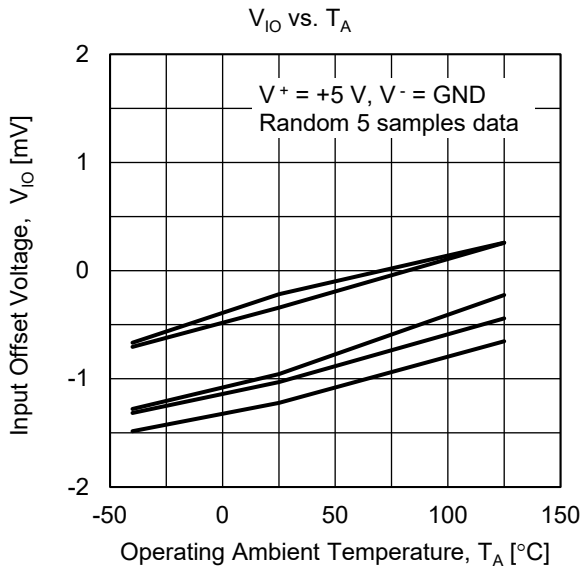
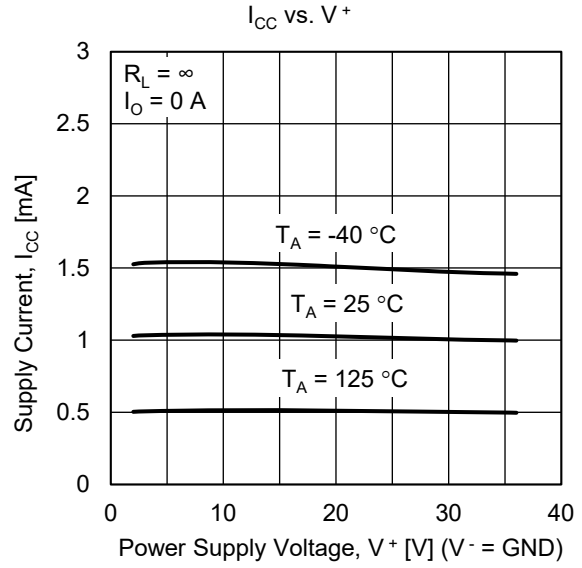
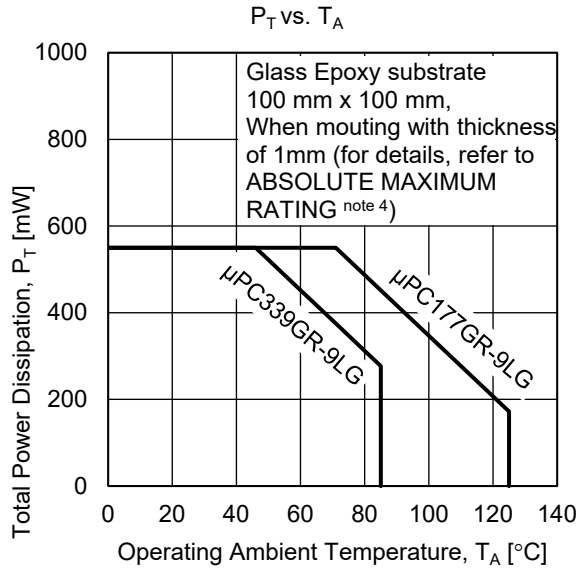

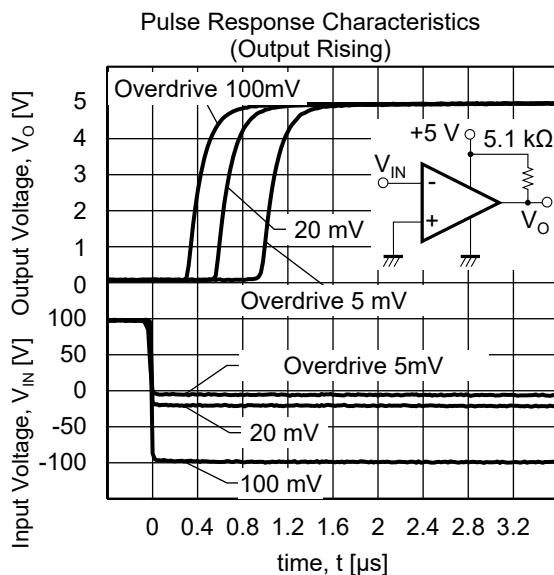
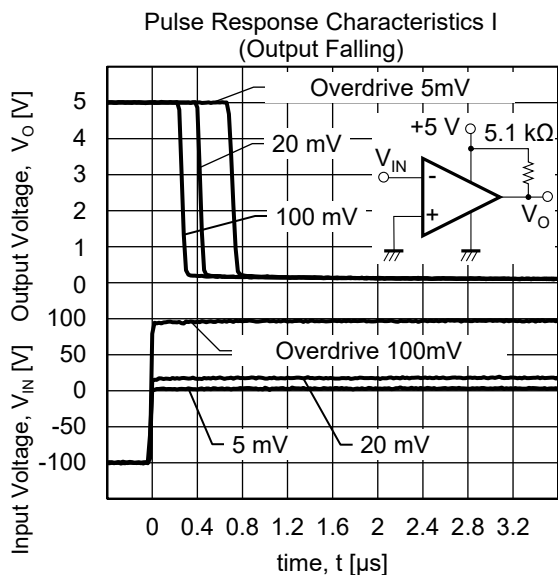

## USE WITH PRECAUTIONS

- **Managing unused circuits**

If there is an unused circuit, the following connection is recommended.

### Example of unused circuit process

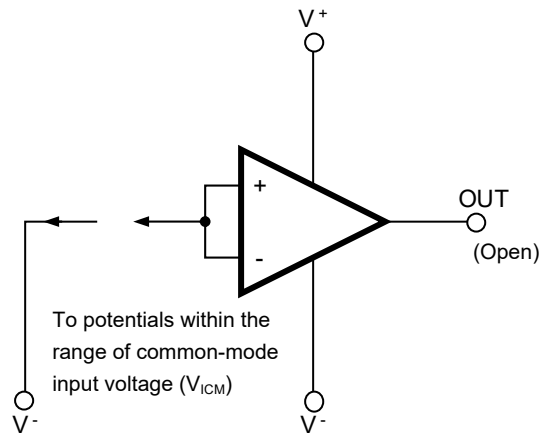

- **Ratings of input/output pin voltage**

When the voltage of input/output pin exceeds the absolute maximum rating, the parasitic diode within the IC may conduct, causing characteristics degradation or damage. In addition, if the input pin is lower than  $V^-$ , or the output pin exceeds the power supply voltage, it is recommended to make a clamping circuit using a diode with low forward voltage (e.g.: Schottky diode) as protection.

- **Range of common-mode input voltage**

When the supply voltage does not meet the condition of electrical characteristics, the range of common-mode input voltage is as follows.

$$V_{ICM} \text{ (TYP.)}: V^- \sim V^+ - 1.5 \text{ [V]} \text{ (} T_A = 25 \text{ }^\circ\text{C)}$$

During designing, do include some tolerance by considering temperature characteristics etc.

- **Regarding Input Current**

The Input Bias Current [ $I_B$ ] specified in the electrical characteristics table, is the average value of current flowing through the +input terminal [ $I_N$ ] and the current flowing through the -input terminal [ $I_P$ ] in the balanced state of the differential amplifier circuit of the input stage (with negative feedback).

Therefore, since the differential amplifier circuit of the input stage is not balanced during comparison operation (in the case of comparator operation), the input current flows twice as much towards the low potential terminal.

- **Handling of ICs**

When stress is added to the ICs due to warpage or bending of a board, the characteristic may fluctuates due to piezoelectric (piezo) effect. Therefore, pay attention to warpage or bending of a board.

## PACKAGE DRAWINGS

### 14-PIN PLASTIC TSSOP

JEITA Package code	RENESAS code	Previous code	MASS(TYP.) [g]
P-TSSOP14-0225-0.65	PTSP0014JB-A	P14GR-65-9LG-1	—

Unit : mm

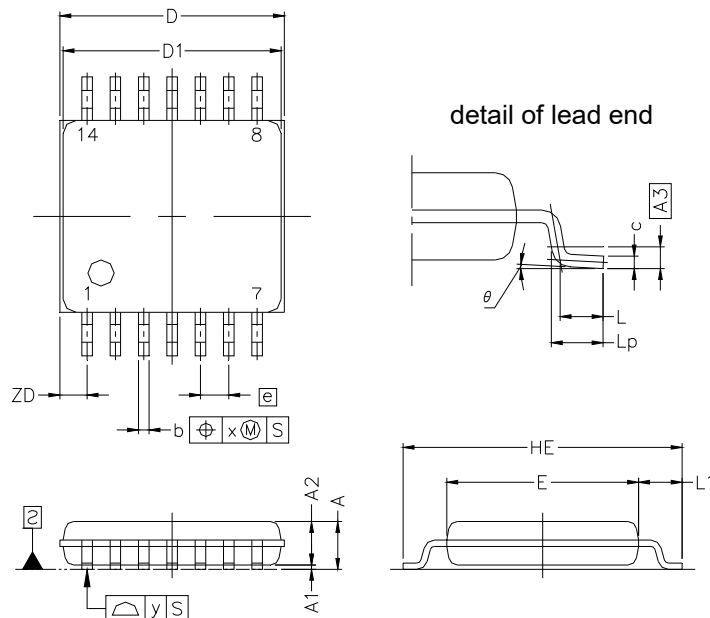

#### NOTE

Each lead centerline is located within 0.10 mm of its true position at maximum material condition.

ITEM	MILLIMETERS
D	5.15 ±0.15
D1	5.00 ±0.10
E	4.40 ±0.10
HE	6.40 ±0.20
A	1.20 MAX.
A1	0.10 ±0.05
A2	1.00 ±0.05
A3	0.25
b	0.24 <sup>+0.06</sup> <sub>-0.05</sub>
c	0.145 ±0.055
L	0.5
Lp	0.60 ±0.15
L1	1.00 ±0.20
θ	3° <sup>+5°</sup> <sub>-3°</sub>
e	0.65
x	0.10
y	0.10
ZD	0.625