

μPC259, 4560

High Performance, Low Noise

Dual Operational Amplifier

R03DS0146EJ0100

Rev.1.00

2019.06.13

DESCRIPTION

The μPC259 and 4560 are dual operational amplifier with a built-in phase compensation circuit. The electrical characteristics are equivalent to the μPC258 and 4558, and can flow a large amount of output current. In addition, the slew rate is about 2.8 times of the μPC258, 4558.

Therefore, applications such as active filters, audio amplifiers and VCOs can be realized with a simple circuit configuration.

Depending on the operating ambient temperature, μPC259 is suitable for communication application while μPC4560 is suitable for general-purpose usage.

FEATURES

- Input Offset Voltage ±0.5 mV (TYP.)
- Input Offset Current ±5 nA (TYP.)
- Input Bias Current 60 nA (TYP.)
- Slew Rate 2.8 V/μs (TYP.)
- Output Current over 25 mA
- Built-In Phase Compensation Circuit
- Standard Dual Op-Amp terminal connection (pin compatible)

ORDERING INFORMATION

| Ordering Name | Package |
|---------------|---|
| μPC259G2-A | 8-pin plastic SOP (5.72 mm (225 mil)) |
| μPC4560G2-A | 8-pin plastic SOP (5.72 mm (225 mil)) |

EQUIVALENT CIRCUIT (1/2 Circuit)

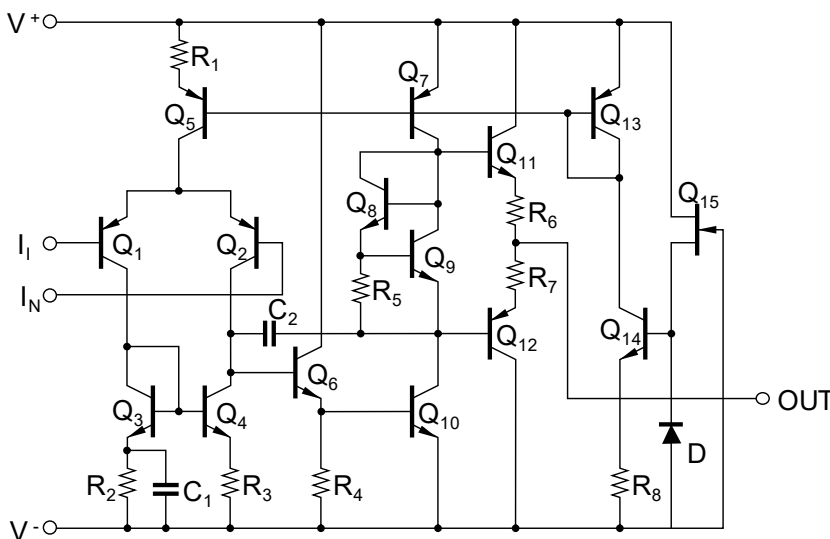

PIN CONFIGURATION (Top View)

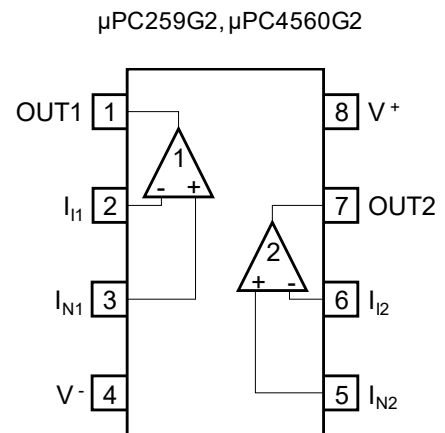

ABSOLUTE MAXIMUM RATINGS (T_A = 25 °C)

| PARAMETER | SYMBOL | μPC259G2 | μPC4560G2 | UNIT |
|--|---------------------------------|---|-----------|------|
| Supply Voltage ^{Note1} | V ⁺ - V ⁻ | -0.3 ~ +36 | | V |
| Differential Input Voltage | V _{ID} | ±30 | | V |
| Input Voltage ^{Note2} | V _I | V ⁻ -0.3 ~ V ⁺ +0.3 | | V |
| Output Applied Voltage ^{Note3} | V _O | V ⁻ -0.3 ~ V ⁺ +0.3 | | V |
| Total Power Dissipation ^{Note4} | P _T | 440 | | mW |
| Output Short Circuit Duration ^{Note5} | | 0 | | s |
| Operating Ambient Temperature | T _A | -40 ~ +85 | -20 ~ +80 | °C |
| Storage Temperature | T _{stg} | -55 ~ +125 | | °C |

- [Note]
- Note that reverse connections of the power supply may damage the ICs.
 - The input terminal must be apply within the input voltage range to avoid deteriorating or damaging the device characteristic. Do not exceed the ratings including during transition state such as ON/OFF, etc. The Op-Amp input voltage must operates within the electrical characteristics range of input common-mode voltage.
 - The output terminal must be apply within the output voltage range to avoid deteriorating or damaging the device characteristic. Do not exceed the ratings including during transition state such as ON/OFF, etc. The Op-Amp output voltage must operates within the electrical characteristics range of maximum output voltage.
 - This is the value at T_A ≤ +25 °C. De-rate value at -4.4 mW/°C when T_A > 25 °C.
 - Protection against load shorts is required. Please use the total loss and the de-rating value from Note 4.

RECOMMENDED OPERATING CONDITIONS

| PARAMETER | SYMBOL | MIN. | TYP. | MAX. | UNIT |
|----------------------|----------------|------|------|------|------|
| Power Supply Voltage | V [±] | ±4 | | ±16 | V |

ELECTRICAL CHARACTERISTICS (T_A = 25 °C, V[±] = ±15 V)

| PARAMETER | SYMBOL | MIN. | TYP. | MAX. | UNIT | TEST CONDITION |
|-------------------------------------|------------------|-------|--------|------|-------------------|---|
| Input Offset Voltage | V _{IO} | | ±0.5 | ±6.0 | mV | R _s ≤ 10 kΩ |
| Input Offset Current | I _{IO} | | ±5 | ±200 | nA | |
| Input Bias Current ^{Note6} | I _B | | 60 | 500 | nA | |
| Large Signal Voltage Gain | A _V | 20000 | 180000 | | | R _L ≥ 2 kΩ, V _O = ±10 V |
| Power Consumption | P _d | | 120 | 170 | mW | I _O = 0 A |
| Common Mode Rejection Ratio | CMR | 70 | 100 | | dB | R _s ≤ 10 kΩ |
| Supply Voltage Rejection Ratio | SVR | | 10 | 150 | μV/V | R _s ≤ 10 kΩ |
| Output Voltage Swing | V _{om} | ±12 | ±14 | | V | R _L ≥ 2 kΩ |
| Output Voltage Swing | V _{om} | ±10 | ±13 | | V | I _O = ±25 mA |
| Common Mode Input Voltage Range | V _{ICM} | ±12 | ±14 | | V | |
| Slew Rate | SR | | 2.8 | | V/μs | A _V = 1 |
| Input Equivalent Noise Voltage | V _n | | 6 | | μV _{p-p} | R _s = 1 kΩ, f = 1 Hz ~ 1 kHz (Fig 1) |
| Channel Separation | | | 105 | | dB | f = 1 kHz (Fig 2) |

[Note] 6. The direction of the input bias current is the same direction that flows out from the IC because the first stage is composed of PNP transistor.

TEST CIRCUIT

Fig 1 Noise Test Circuit

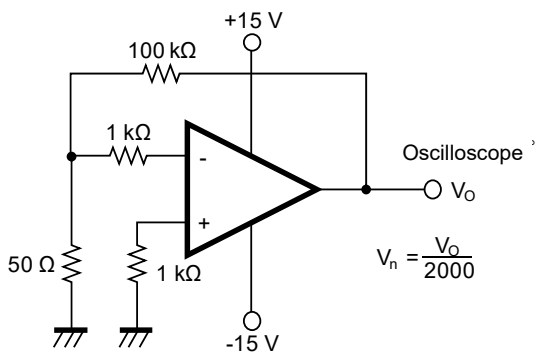
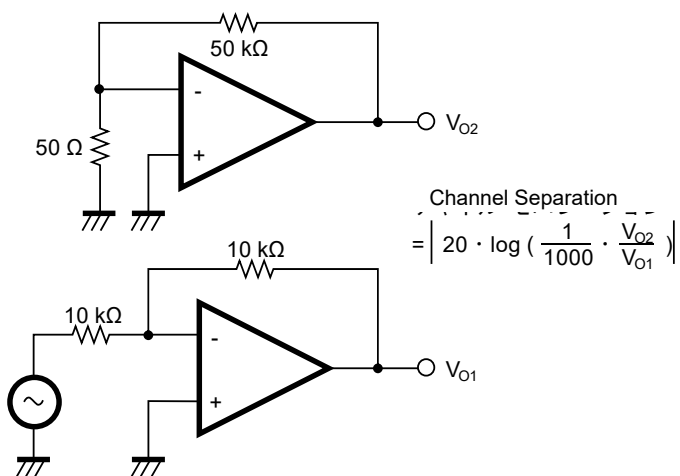
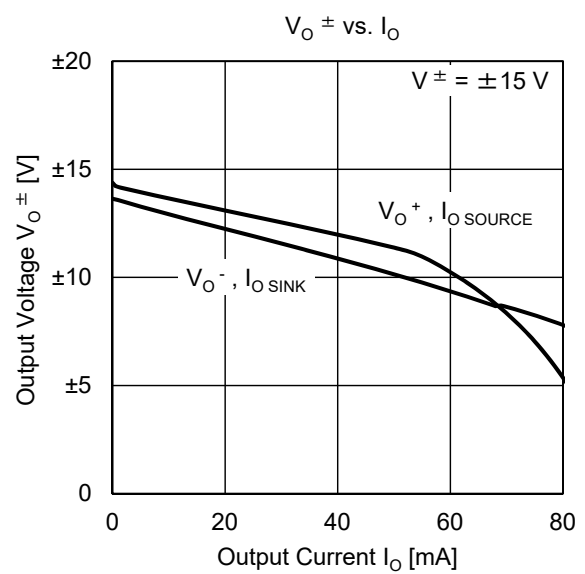
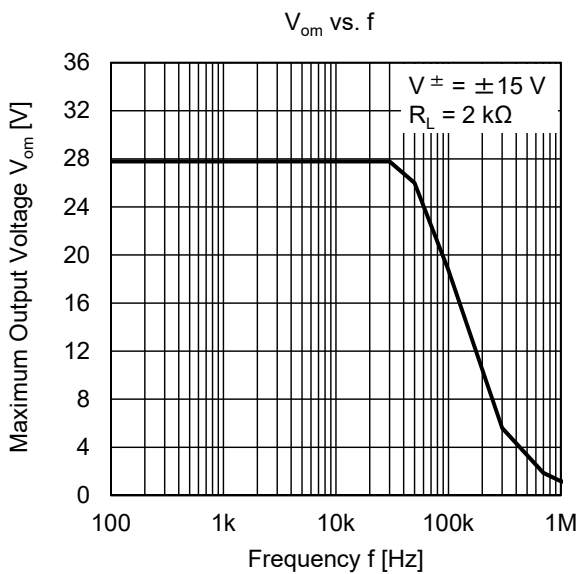
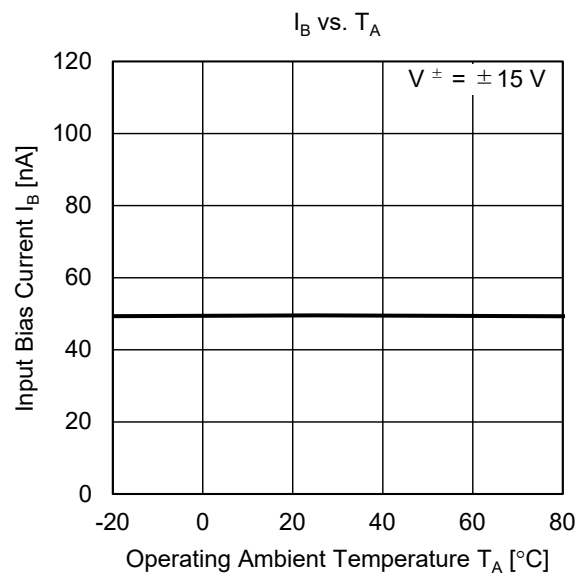
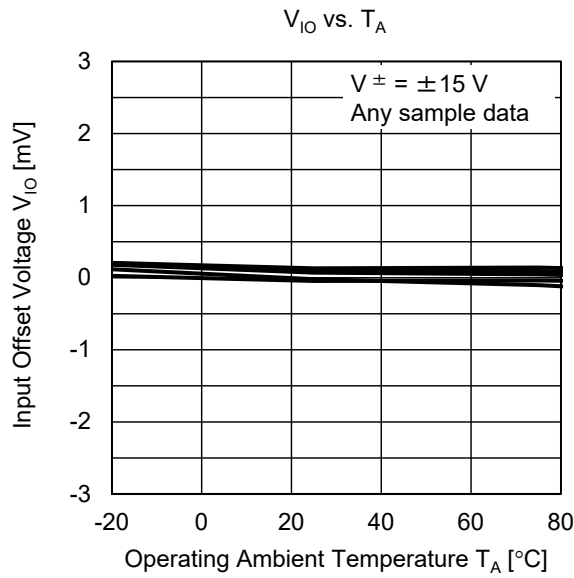
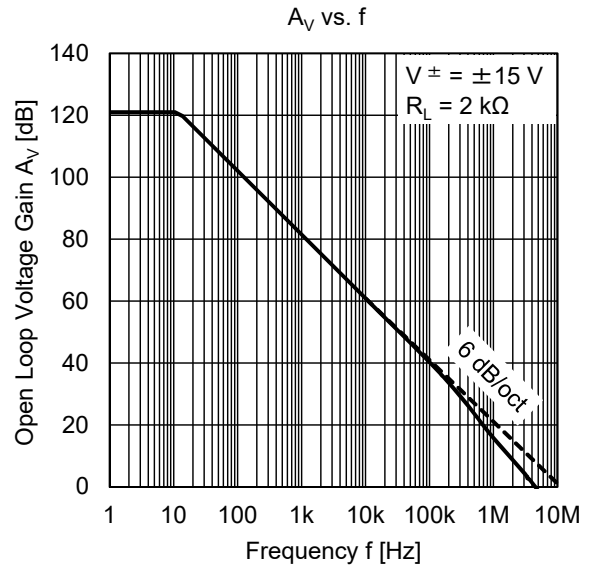
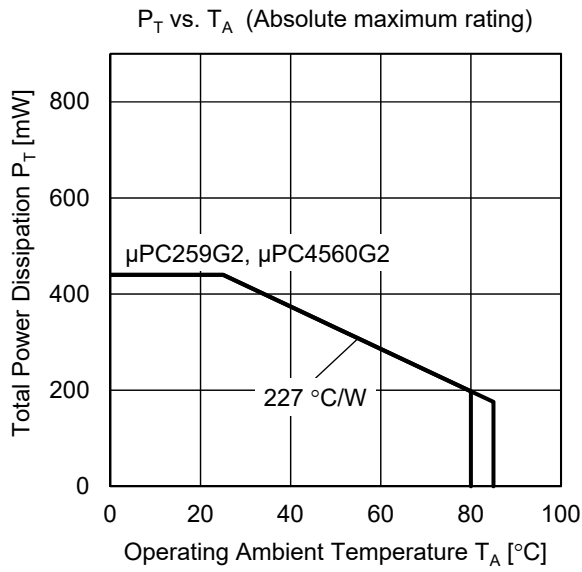
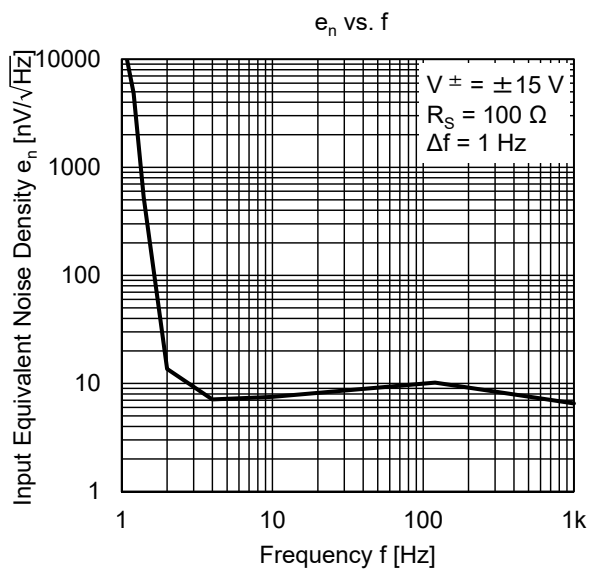
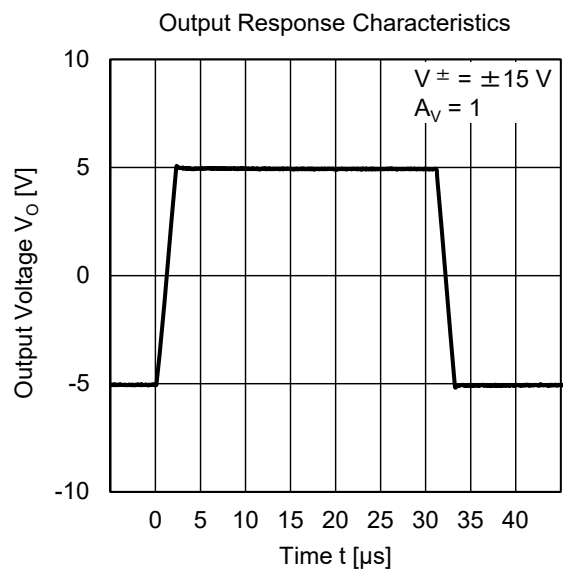
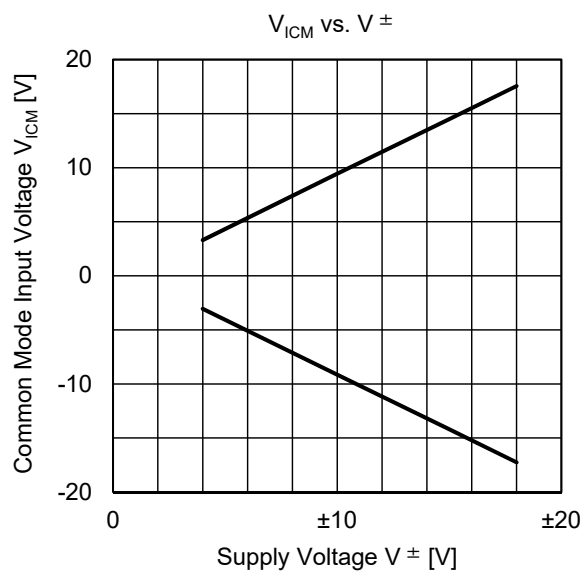
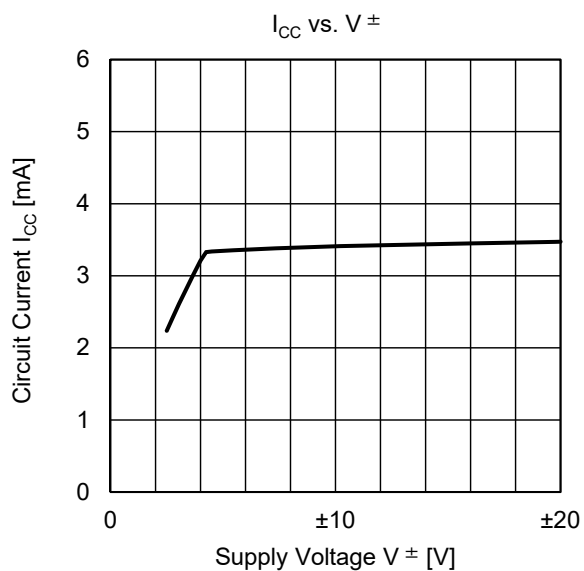

Fig 2 Channel Separation Test Circuit



ELECTRICAL CHARACTERISTICS CURVE (T_A = 25 °C, TYP.) (REFERENCE VALUE)





APPLICATION CIRCUIT EXAMPLE

Headphone Amplifier

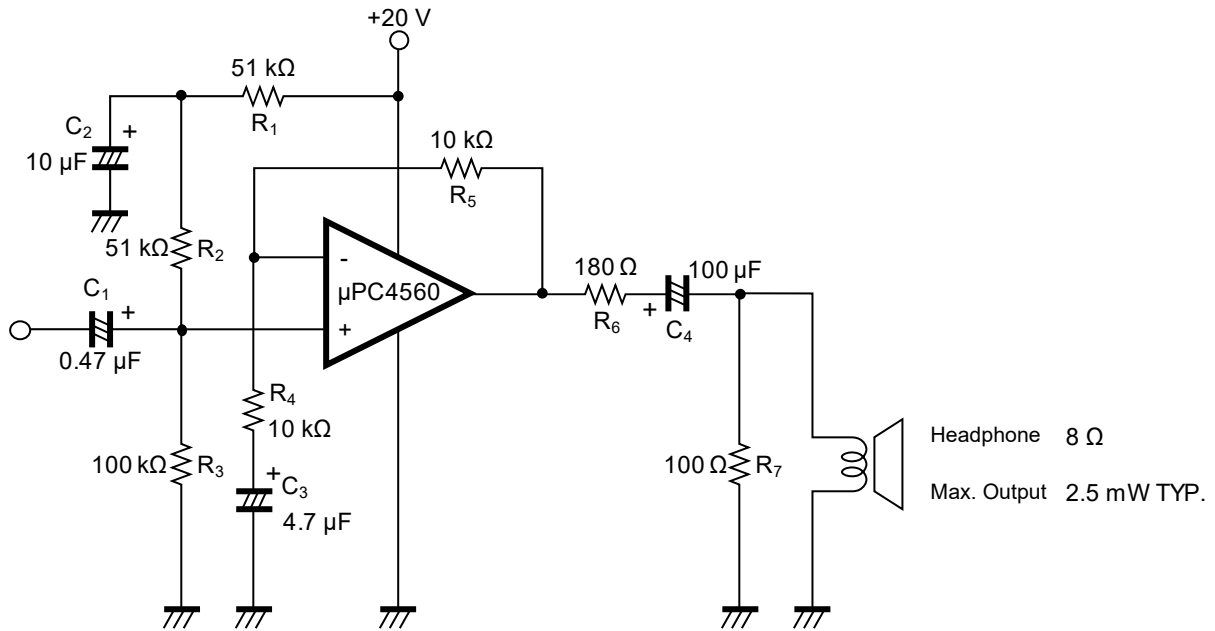

RIAA Amplifier

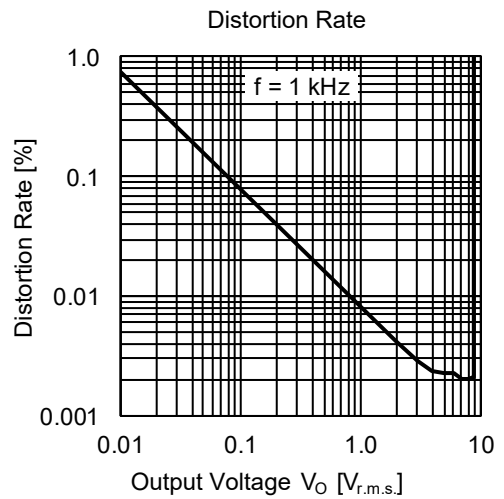
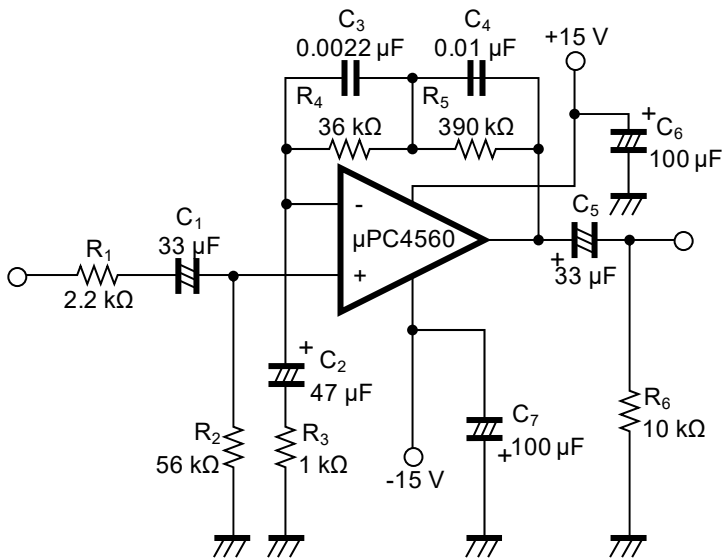

USE WITH PRECAUTIONS

- Managing unused circuits

If there is an unused circuit, the following connection is recommended.

Example of handling unused circuit

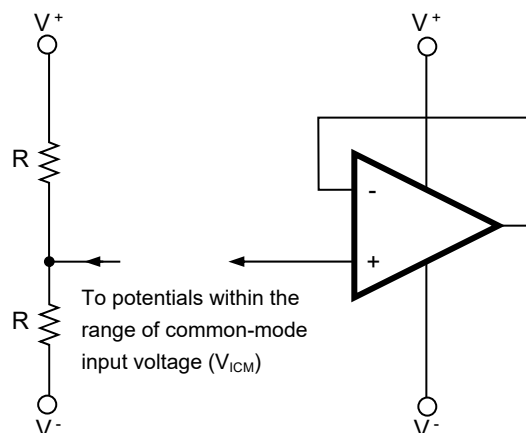

Note in this example, an intermediate voltage of V^+ and V^- is applied.

- Power Supply (Dual Power Supply / Single Power Supply)**

The op amp operates when a predetermine voltage is applied between $V^+ - V^-$. Therefore, while it operates from a single power supply ($V^- = \text{GND}$), it is not possible to operate the input and output near GND. So please be careful of the common-mode input voltage range and maximum output voltage.

- Ratings of input/output pin voltage**

When the voltage of input/output pin exceeds the absolute maximum rating, the parasitic diode within the IC may conduct, causing characteristics degradation or damage. In addition, if the input pin is lower than V^- , or the output pin exceeds the power supply voltage, it is recommended to make a clamping circuit using a diode with low forward voltage (e.g.: Schottky diode) as protection.

- Range of common-mode input voltage**

When the supply voltage does not meet the condition of electrical characteristics, the range of common-mode input voltage is as follows.

$$V_{ICM} (\text{TYP.}) : V^- + 1 \sim V^+ - 1 [\text{V}] (T_A = 25 \text{ }^\circ\text{C})$$

During designing, do include some margin by considering characteristics variation, temperature characteristics etc.

- Maximum Output Voltage**

The TYP. value range of the maximum output voltage when the supply voltage does not meet the condition of electrical characteristics is as follows:

$$V_{om}^+ (\text{TYP.}) : V^+ - 1 [\text{V}] (T_A = 25 \text{ }^\circ\text{C}), V_{om}^- (\text{TYP.}) : V^- + 1 [\text{V}] (T_A = 25 \text{ }^\circ\text{C})$$

During designing, do include some margin by considering characteristics variation, temperature characteristics and so on. In addition, also note that the output voltage range ($V_{om}^+ - V_{om}^-$) will become narrow when the output current increases.

- Handling of ICs**

When stress is added to the ICs due to warpage or bending of a board, the characteristic may fluctuates due to piezoelectric (piezo) effect. Therefore, pay attention to warpage or bending of a board.

PACKAGE DRAWINGS

8-PIN PLASTIC SOP

| JEITA Package code | RENESAS code | Previous code | MASS (TYP.) [g] |
|--------------------|--------------|---------------|-----------------|
| P-SOP8-0225-1.27 | PRSP0008DL-A | S8GM-50-225B | 0.08 |

Unit: mm

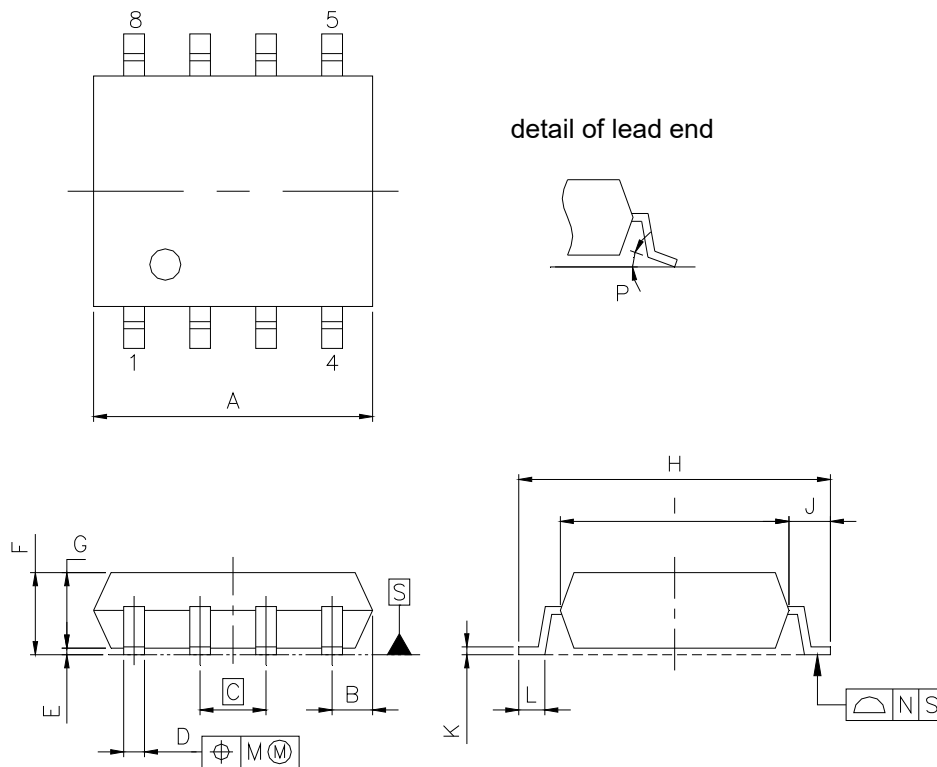

NOTE

Each lead centerline is located within 0.12 mm of its true position (T.P.) at maximum material condition.

| ITEM | MILLIMETERS |
|------|--|
| A | 5.2 ^{+0.17} / _{-0.20} |
| B | 0.78 MAX |
| C | 1.27 (T.P) |
| D | 0.42 ^{+0.08} / _{-0.07} |
| E | 0.1 ±0.1 |
| F | 1.59 ±0.21 |
| G | 1.49 |
| H | 6.5 ±0.3 |
| I | 4.4 ±0.15 |
| J | 1.1 ±0.2 |
| K | 0.17 ^{+0.08} / _{-0.07} |
| L | 0.6 ±0.2 |
| M | 0.12 |
| N | 0.10 |
| P | 3° ^{+7°} / _{-3°} |