

US1A-HF Thru. US1M-HF

Reverse Voltage: 50 to 1000 Volts

Forward Current: 1 Amp

RoHS Device

Halogen Free

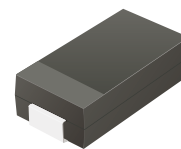

Features

- For surface mounted applications.
- Low profile package.
- Glass passivated chip junction.
- Easy to pick and place.
- High efficiency.

Mechanical data

- Case: SMA
- Terminals: Solderable per MIL-STD-750, method 2026.

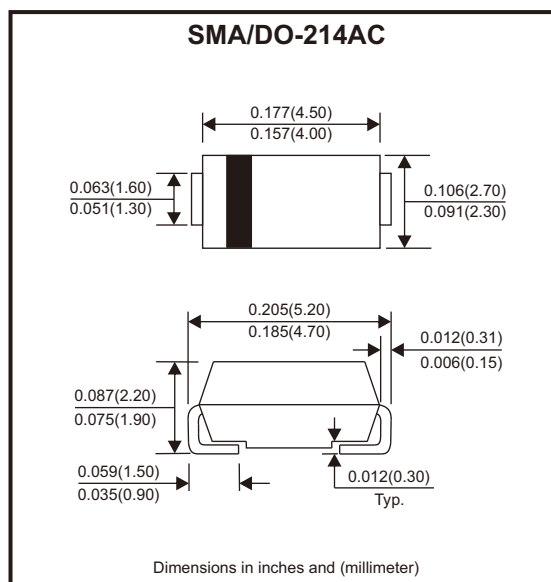

Circuit Diagram



Maximum Ratings and Electrical Characteristics

Ratings at 25°C ambient temperature unless otherwise specified.

Single phase, half wave, 60Hz resistive or inductive load, for capacitive load, derate by 20%

Parameter	Symbols	US1A -HF	US1B -HF	US1D -HF	US1G -HF	US1J -HF	US1K -HF	US1M -HF	Units
Maximum repetitive peak reverse voltage	V_{RRM}	50	100	200	400	600	800	1000	V
Maximum RMS voltage	V_{RMS}	35	70	140	280	420	560	700	V
Maximum DC blocking voltage	V_{DC}	50	100	200	400	600	800	1000	V
Maximum average forward rectified current at $T_c = 125^\circ\text{C}$	$I_{F(AV)}$	1							A
Peak forward surge current, 8.3ms single half sine-wave superimposed on rated load	I_{FSM}	30							A
Max. instantaneous forward voltage at 1A	V_F	1.0		1.3		1.65		V	
Maximum DC reverse current at rated DC blocking voltage $T_a = 25^\circ\text{C}$ $T_a = 125^\circ\text{C}$	I_R	5 100							μA
Maximum reverse recovery time (Note 1)	t_{rr}	50				75			ns
Typical thermal resistance (Note 2)	$R_{\theta JA}$	75							$^\circ\text{C/W}$
Typical junction capacitance (Note 3)	C_j	15							pF
Operating and storage temperature range	T_j, T_{stg}	-55 ~ +150							$^\circ\text{C}$

Notes: 1. Measured with $I_F = 0.5\text{A}$, $I_R = 1\text{A}$, $I_{rr} = 0.25\text{A}$.

2. P.C.B. mounted with 2.0" X 2.0" (5 X 5 cm) copper pad areas.

3. Measured at 1 MHz and applied reverse voltage of 4 V D.C

Company reserves the right to improve product design, functions and reliability without notice.

REV:A

Rating and Characteristic Curves (US1A-HF Thru. US1M-HF)

Fig.1 - Forward Current Derating Curve

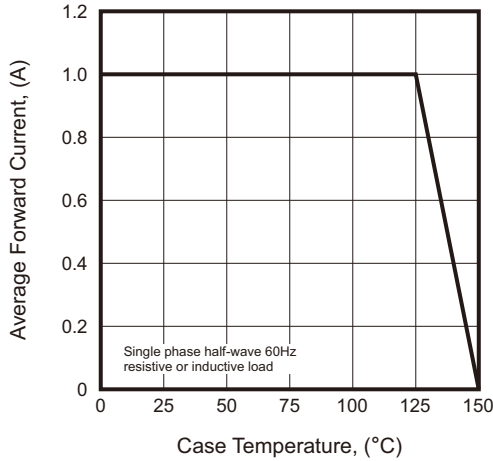

Fig.2 - Typical Reverse Characteristics

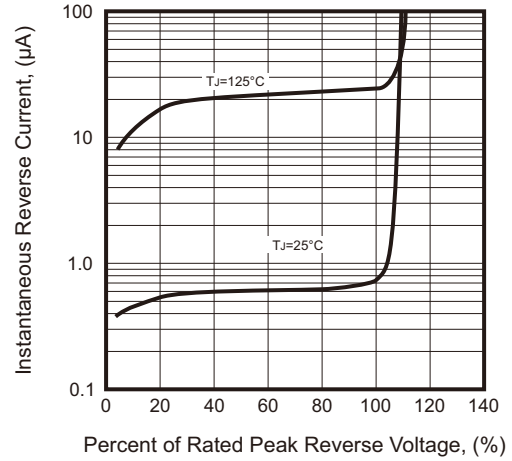

Fig.3 - Typical Forward Characteristic

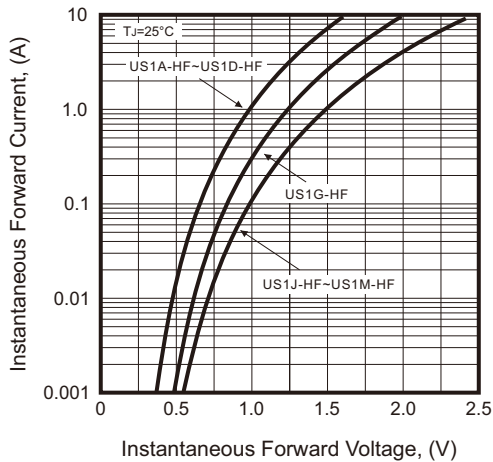

Fig.4 - Maximum Non-Repetitive Peak Forward Surge Current

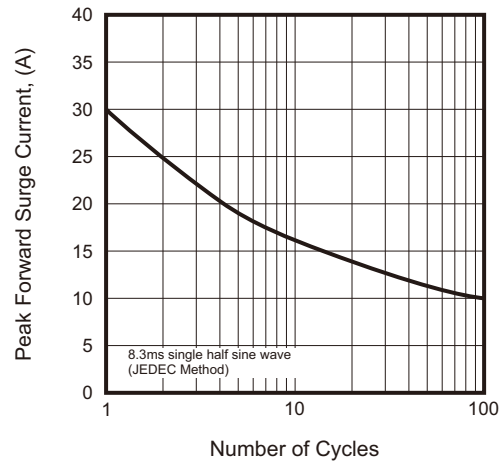

Fig.5 - Typical Transient Thermal Impedance

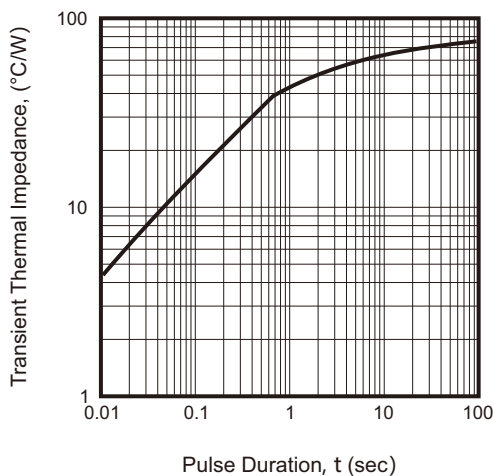
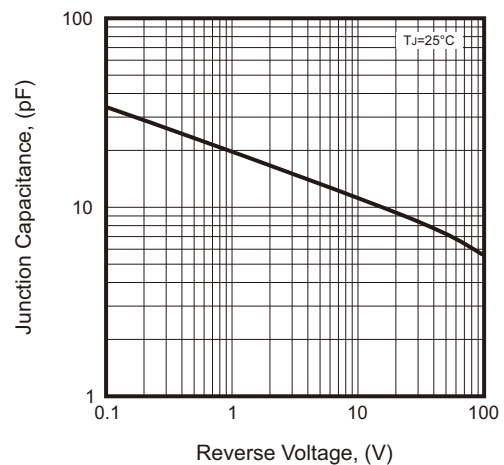
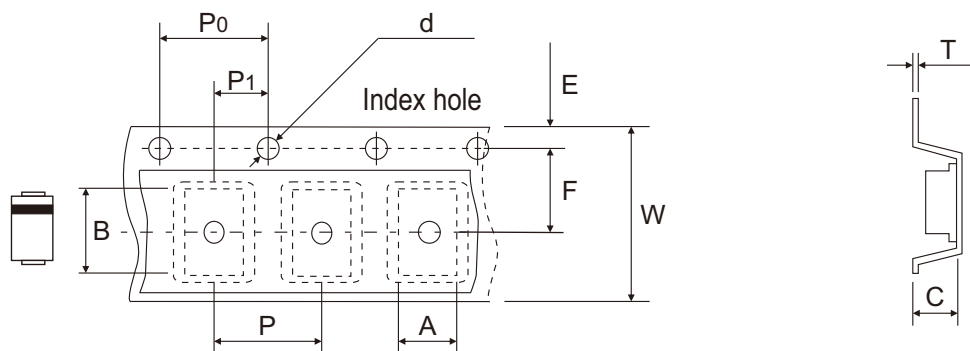

Fig.6 - Typical Junction Capacitance



Reel Taping Specification



DO-214AC (SMA)	SYMBOL	A	B	C	d	D	D1	D2
	(mm)	2.70 ± 0.10	5.33 ± 0.10	2.35 ± 0.10	1.55 ± 0.05	330 ± 2.00	75.00 ± 1.00	13.00 ± 0.20
	(inch)	0.106 ± 0.004	0.210 ± 0.004	0.093 ± 0.004	0.061 ± 0.002	12.992 ± 0.079	2.953 ± 0.039	0.512 ± 0.008

DO-214AC (SMA)	SYMBOL	E	F	P	P0	P1	T	W	W1
	(mm)	1.75 ± 0.10	5.50 ± 0.05	4.00 ± 0.10	4.00 ± 0.10	2.00 ± 0.10	0.20 ± 0.03	12.00 ± 0.30	14.70 + 2.00 - 1.00
	(inch)	0.069 ± 0.004	0.217 ± 0.002	0.157 ± 0.004	0.157 ± 0.004	0.079 ± 0.004	0.008 ± 0.001	0.472 ± 0.012	0.579 + 0.079 - 0.039

Company reserves the right to improve product design, functions and reliability without notice.

REV:A