

USB-ANNA-B4

USB for ANNA-B402 and ANNA-B412 modules

User guide



Abstract

This document describes how to set up the USB-ANNA-B4 evaluation kit to evaluate ANNA-B4 series standalone Bluetooth® 5.1 low energy modules. It also describes the different options for debugging and testing the development capabilities included supported by the evaluation board.

Document information

Title	USB-ANNA-B4		
Subtitle	USB for ANNA-B402 and ANNA-B412 modules		
Document type	User guide		
Document number	UBX-22008565		
Revision and date	R01	26-Sep-2022	
Disclosure restriction	C1-Public		

This document applies to the following products:

Product name	Type number	Firmware version	PCN reference
USB-ANNA-B402	USB-ANNA-B402-00	N/A	-
USB-ANNA-B412	USB-ANNA-B412-00	N/A	-

u-blox or third parties may hold intellectual property rights in the products, names, logos, and designs included in this document. Copying, reproduction, or modification of this document or any part thereof is only permitted with the express written permission of u-blox. Disclosure to third parties is permitted for clearly public documents only.

The information contained herein is provided "as is" and u-blox assumes no liability for its use. No warranty, either express or implied, is given, including but not limited to, with respect to the accuracy, correctness, reliability, and fitness for a particular purpose of the information. This document may be revised by u-blox at any time without notice. For the most recent documents, visit www.u-blox.com.

Copyright © u-blox AG

Contents

Document information	2
Contents	3
1 Product description	4
1.1 Key features	4
1.2 USB-ANNA-B4 block diagram.....	5
1.3 Connectors	5
2 Setting up the evaluation board	6
2.1 Evaluation board setup.....	6
2.1.1 Software and power prerequisites	6
2.1.2 Assigning COM ports	6
2.2 Software and flashing.....	6
2.2.1 USB-ANNA-B412.....	6
2.2.2 USB-ANNA-B402.....	7
3 Interfaces and peripherals	8
3.1 Buttons and LEDs	8
3.2 USB to UART interface	8
3.3 I2C temperature sensor	8
Appendix	9
A Schematic and assembly drawing	9
B Glossary	10
Related documents	11
Revision history	11
Contact	11

1 Product description

USB-ANNA-B4 is an evaluation board with a USB form factor. Accommodated within a standard USB stick that plugs directly into the USB port on your computer, the board allows quick prototyping of a variety of extremely low-powered Internet of Things (IoT) applications. USB-ANNA-B4 supports the full Bluetooth Core specification v5.1 and IEEE 802.15.4 standard.

USB-ANNA-B4 boards are available in two variants to accommodate alternative software solutions:

- USB-ANNA-B402 – includes an Open CPU ANNA-B402 module with an internal, 2.4 GHz antenna (integrated in the SiP).
- USB-ANNA-B412 – includes an ANNA-B412 module with pre-flashed u-connectXpress software and an internal, 2.4 GHz antenna (integrated in the SiP).



Figure 1: USB-ANNA-B402/B412 evaluation board

USB-ANNA-B4 evaluation boards support the SEGGER J-Link debug interface that can be used with the Open CPU, ANNA-B402, variants of the USB stick.

The manufacturer of the nRF52833 SoC, Nordic Semiconductor, provide a free Software Development Kit (SDK) that includes a broad selection of drivers, libraries, and example applications that can be used for rapid prototyping.

USB-ANNA-B4 USB evaluation sticks include an FTDI chip that converts USB data to UART data for module communication and require download of the FTDI driver. USB sticks integrating ANNA-B412 u-connectXpress module variants are preferably controlled using s-center evaluation software [7].

USB-ANNA-B4 software and documentation is available at www.u-blox.com/evk-search.

1.1 Key features

The USB-ANNA-B4 Bluetooth Low Energy has the following features and interfaces:

- Full Bluetooth 5.1 functionality
- 802.15.4 PHY
- I2C interface
 - A temperature sensor, LM75B, is available on the I2C interface.
- USB-ANNA-B412 supports u-connectXpress software for accelerated time to market
- USB-ANNA-B402 with Open CPU for embedded application development
- Full UART to USB converter with a virtual COM port for control of the extended UART features of the u-connectXpress software
- On-board J-link 6-Pins-Needle connector
- RGB LED
- Reset push button
- SW2 for Reset of UART settings or connection trigger in u-connectXpress

1.2 USB-ANNA-B4 block diagram

Figure 2 shows the major interfaces and internal connections supported on the USB-ANNA-B4.

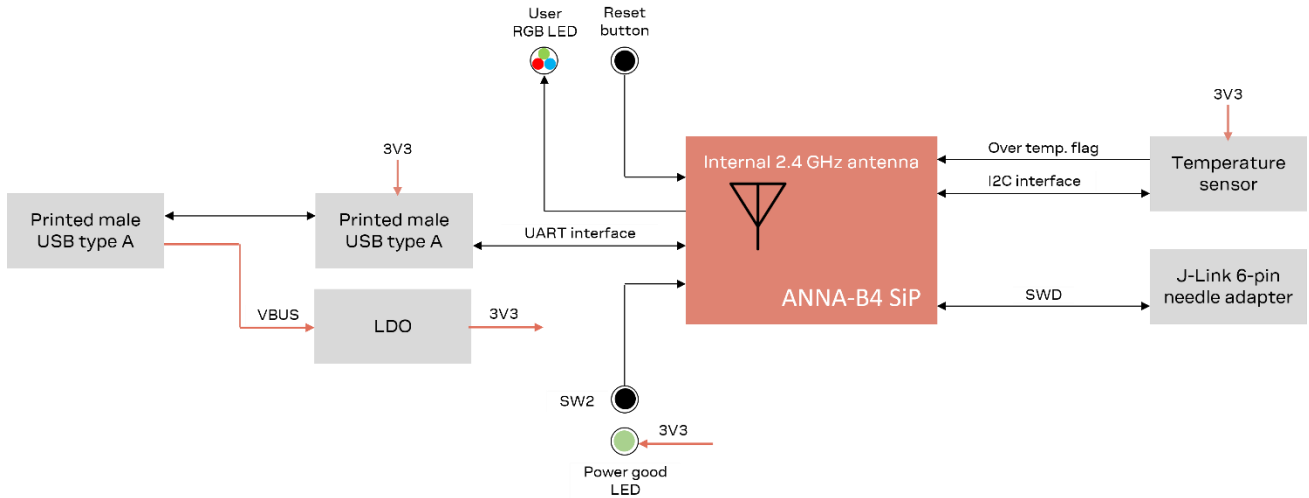

Figure 2: USB-ANNA-B4 block diagram

1.3 Connectors

Table 1 describes the available connectors of the USB-ANNA-B4, as shown in Figure 3.

Connector	Function	Description
J1	USB power supply	5 V USB power supply
J2	Cortex debug connector	J-link 6-Pin Needle Adapter used to connect external debuggers to the ANNA-B402 module. ANNA-B402 modules support Serial Wire debug (SWD) and Serial Wire Viewer, but not JTAG debug.

Table 1: USB-ANNA-B4 connector descriptions



Figure 3: Available connectors, pinout, and designators

2 Setting up the evaluation board

2.1 Evaluation board setup

USB-ANNA-B402 is intended for the purpose of customer software development. In addition to the SWD interface, it includes a bootloader that can be used to flash the board.

USB-ANNA-B412 is delivered with pre-installed u-connectXpress software and can only be used via the UART interface that is made available when plugging in the device.

2.1.1 Software and power prerequisites

1. Before connecting the USB board, download and install the latest u-blox s-center evaluation software from the u-blox website (required for USB-ANNA-B412 only)
2. Plug in USB-ANNA-B4 to the USB host.

The operating system installs the correct drivers automatically. The drivers need only be installed once when you connect the unit to a new computer.



If the drivers are not installed automatically, download the FTDI driver FT234XD-R

2.1.2 Assigning COM ports

A COM port is automatically assigned to the device by Windows:

- The COM port labelled “USB Serial Port” is used to communicate with the UART interface of the USB-ANNA-B4.

Windows 7

To view assigned COM ports in Windows 7:

1. Open the **Control Panel** and select **Hardware and Sound**.
2. Open the **Device Manager** in **Devices and Printers**. This opens the Device Manager window where you can view the assigned COM ports.

Windows 10

To view assigned COM ports in Windows 10:

1. Right click the Windows **Start** button.
2. Select **Device Manager**.

2.2 Software and flashing

2.2.1 USB-ANNA-B412

USB-ANNA-B412 includes an ANNA-B412 module running u-connectXpress software. The software is preinstalled on the module.



For the latest software go <https://www.u-blox.com>. Instructions for reflashing ANNA-B4 modules can be found in the Software section of the ANNA-B4 system integration manual [1]. The same procedure is applicable for USB-ANNA-B412 evaluation boards.

2.2.1.1 s-center evaluation software

s-center is convenient to use together with ANNA-B412 when running the AT commands supported in u-connectXpress. It also includes predefined functions. Install [s-center](#) evaluation software [7] and set the baud rate to 115200 with 8N1 configuration and flow control. All available AT commands are described in the u-connectXpress AT commands manual [3].

To get started with the u-connectXpress software for USB-ANNA-B412, see the user guide [5].

2.2.2 USB-ANNA-B402

ANNA-B402 is the Open CPU variant of ANNA-B4. You can use the legacy Nordic SDK or nRF Connect SDK for application development, but the latter is recommended for use with the USB-ANNA-B402 evaluation board.

2.2.2.1 nRF Connect SDK

The nRF Connect SDK allows developers to include new features, such as Bluetooth Direction Finding and Bluetooth LE Audio, into customer applications. To use USB-ANNA-B402 together with the Zephyr-based nRF Connect SDK:

- Create your own board definition
- Build the examples in the nRF Connect SDK to use this board definition

For more information about performing these tasks, see the Software section of the ANNA-B4 system integration manual [1]. Reference code for u-blox Open CPU modules is available from the u-blox short range open CPU github repository [6].

2.2.2.2 Nordic Semiconductor SDK

The older (not recommended for new designs) nRF5 SDK is natively a “bare-metal” kit that does not depend on a Real Time Operating System (RTOS). Notably, new features beyond Bluetooth LE 5, like Bluetooth Direction Finding and Bluetooth LE Audio, are not supported in this SDK.

To use the USB-ANNA-B402 together with the legacy Nordic Semiconductor SDK:

- Create your own board file
- Adapt the examples in the Nordic Semiconductor SDK to use this board file

For more information about these tasks, see the Software section of the ANNA-B4 system integration manual [1]. See also the u-blox short range open CPU github repository [6].

2.2.2.3 Software debug options

To debug using the onboard J-Link connector on USB-ANNA-B402, use an external debugger connected to the J-link 6-Pin Needle Adapter with the SEGGER J-Link software [4].

2.2.2.4 Flashing software

USB-ANNA-B402 can be flashed using the J-link connector or over UART using the preflashed bootloader on the ANNA-B402 module. See also the ANNA-B4 SIM [2].

3 Interfaces and peripherals

3.1 Buttons and LEDs

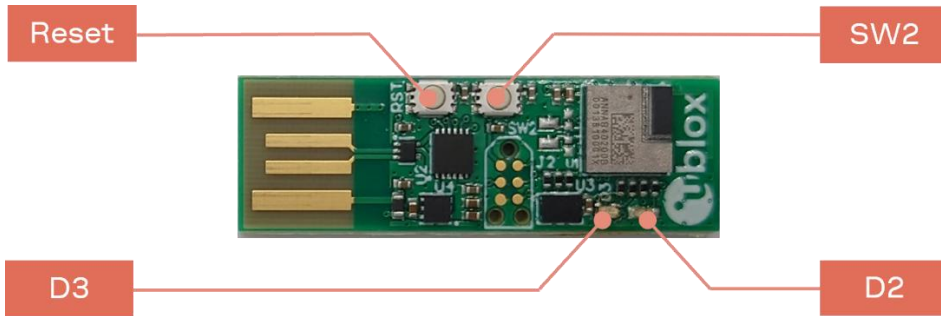

Figure 4: Position of the push buttons and LEDs on the evaluation board

Annotation	Function	Description
RST	Reset button	Connected directly to the ANNA RESET_N pin.
SW2	SWITCH_2	With u-connectXpress this button can be used to reset UART settings. ↗ See also the ANNA-B412 data sheet [1].

Table 2: USB-ANNA-B4 button

Annotation	Function	Description
D2	Power Good Led	Indicates when 3V3 voltage is applied
D3	RGB LED	Connected to the ANNA RED (GPIO_31), GREEN (GPIO_32) and BLUE (GPIO_33) pins. The RGB LED shows the status for u-connectXpress. See also the u-connectXpress user guide [5] for details. ↗ See also the ANNA-B412 data sheet [1].

Table 3: USB-ANNA-B4 LED indicators

3.2 USB to UART interface

A serial COM port is available if the USB board is connected to a PC using the USB connector J1.

3.3 I2C temperature sensor

USB-ANNA-B4 has an LM75B temperature sensor mounted on the PCB. This sensor measures the environmental temperature and can be addressed using the I2C address 0x48.

Appendix

A Schematic and assembly drawing

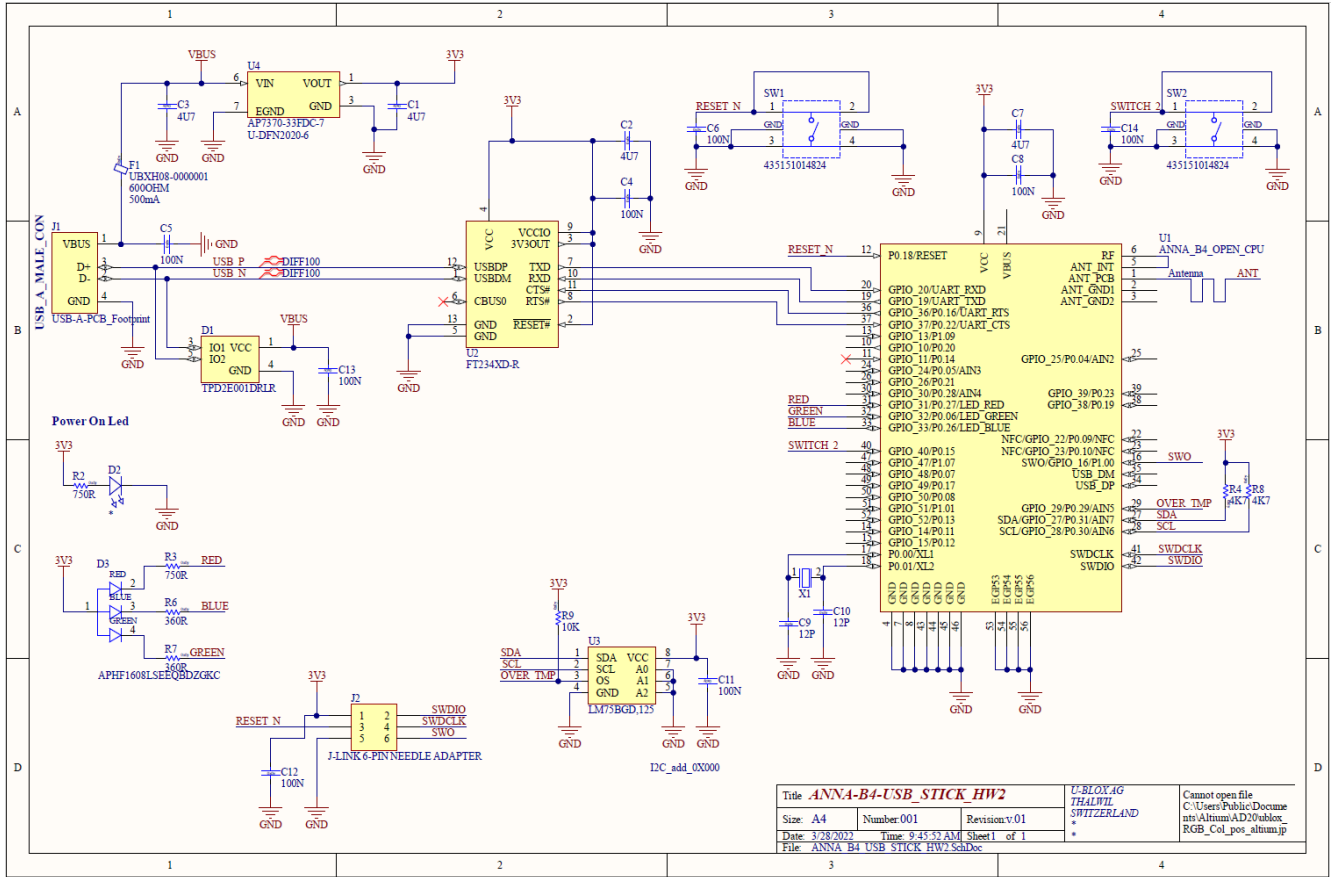

Figure 5 USB-ANNA-B4 schematic

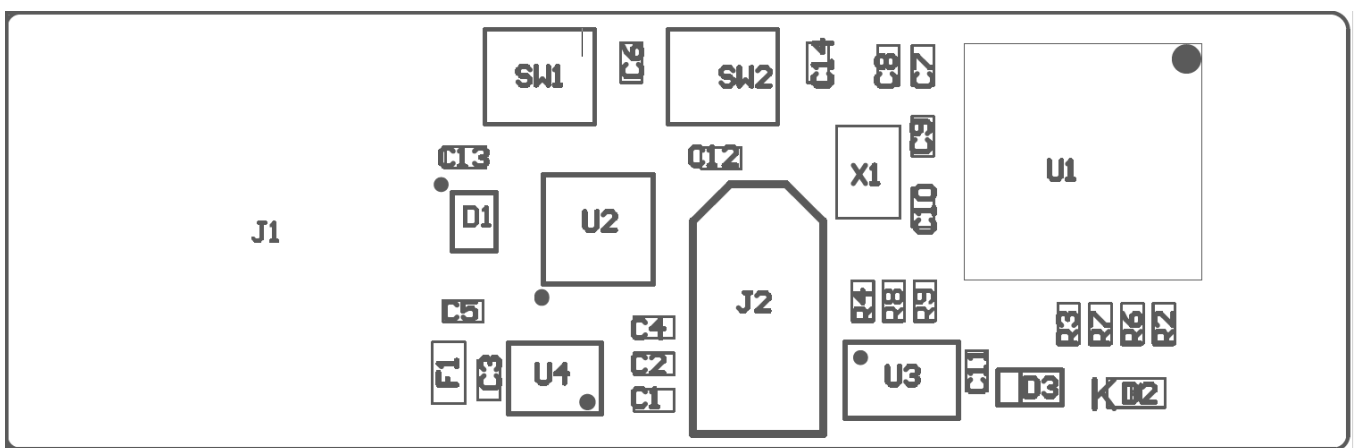

Figure 6 USB-ANNA-B4 assembly drawing – top view

B Glossary

Abbreviation	Definition
EVK	Evaluation kit
GND	Ground
GPIO	General-Purpose Input/Output
I2C	Inter-Integrated Circuit
LED	Light-Emitting Diode
SiP	System in Package
UART	Universal Asynchronous Receiver/Transmitter
USB	Universal Serial Bus

Table 4: Explanation of the abbreviations and terms used