

## Overview

KEMET's QFCE pyroelectric flame sensors combine high sensitivity with fast response times and high dynamic range to ensure rapid and accurate detection of small and large flames, nearby or over larger distances.

These high quality sensors, in their industry standard TO-39 package, integrate a digital, current mode read-out offering high responsivity over the full frequency range of flame flicker from 3 - 30 Hz. Industry standard I<sup>2</sup>C communication enables plug-and-play connectivity to microcontrollers and allows easy tuning and calibration. Programmable gain and filtering offer maximum flexibility in system design.

Their long and maintenance-free operational lifetime and various low power modes make these sensors ideal for any smart or IoT type of applications.

For additional sources of information, please refer to <https://ec.kemet.com/environmental-sensors/>

## Applications

- Industrial
- Industrial IoT
- Oil and gas
- Infrastructure protection
- Forest protection
- Smart home
- Smart building
- Outdoor fire detectors
- Transportation
- Water cannon

## Benefits

- Exceptionally high responsivity
- Wide field of view, typically 100° (subject to filter band pass specification)
- Rapid recovery from thermal and electrical shock (<1 second downtime)
- TO39 package
- Digital output and I<sup>2</sup>C communication
- Programmable gain and filtering
- Various optical filter options
- Integrated configurable amplifier, filter and ADC
- Low power consumption
- Evaluation kit for digital TO infrared flame sensing evaluation

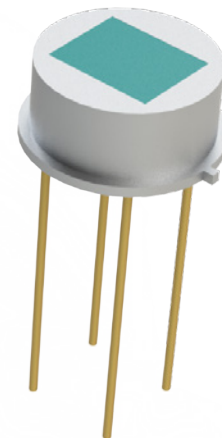

## Ordering Information

USE	QFC	E	A	3911	0	0
Product Family	Series	Sensor Type	Mounting Type	Specification	Packaging	Version
Sensors	QFC = TO39 IR Flame Sensors	E = Serial output, digital K = Evaluation kit	A = Sensor Only 9 = Evaluation Kit Type 9	0000 = Fixed 3911 = 3.91 μm bandpass 4481 = 4.48 μm bandpass 4551 = 4.55 μm bandpass 5001 = 5.0 μm cut on	0 = Bulk	0

## Environmental Compliance

All KEMET Flame Sensors are RoHS and REACH Compliant.



Article 33(1) of the REACH Regulation states that manufacturers and importers of articles (products) are required to notify their customers of the presence of any Substances of Very High Concern (SVHC) in their products exceeding 0.1% by weight and provide instructions on safe use of the product.

KEMET Corporation reports regarding the Article 33(1) of REACH Regulation as follows:

1. *Applicable Product: Flame Sensors (QFC, QFCE, QFS & QFSM series)*

2. *Report for the content of REACH SVHC list:*

*The product(s) above contains a substance by more than 0.1wt% per product weight that was published in the 8th update of the REACH SVHC substances (December 19, 2012).*

3. *Regarding the safety of the flame sensors (Piezoceramic products):*

*The Piezoceramic that is used in this product becomes ceramic by sintering powder containing PZT as the main ingredient. It is chemically stable, with minimum risks toward the human body or environment within the intended use of the product. Please note that risks could occur in the case of inhalation or accidental oral uptake of powder ceramics.*

4. *Technical product information on the flame sensors (Piezoceramic products):*

*The manufacturing technique of the “piezoceramic products” whose main ingredient is Lead Titanium Zirconium Oxide (PZT) has been established, and there is no alternative material that can exhibit superior performance than PZT at this moment. Please note that the piezoceramic is listed as an exempt on RoHS (2011/65/EU) AnnexIII (7c.1).*

5. *The responsibility of piezoceramic manufacturers:*

*Piezoceramic manufacturers report information regarding PZT containment in their products to the customers to obey the article 33 of the REACH regulation*

## Dimensions – Millimeters

### Cross Section View

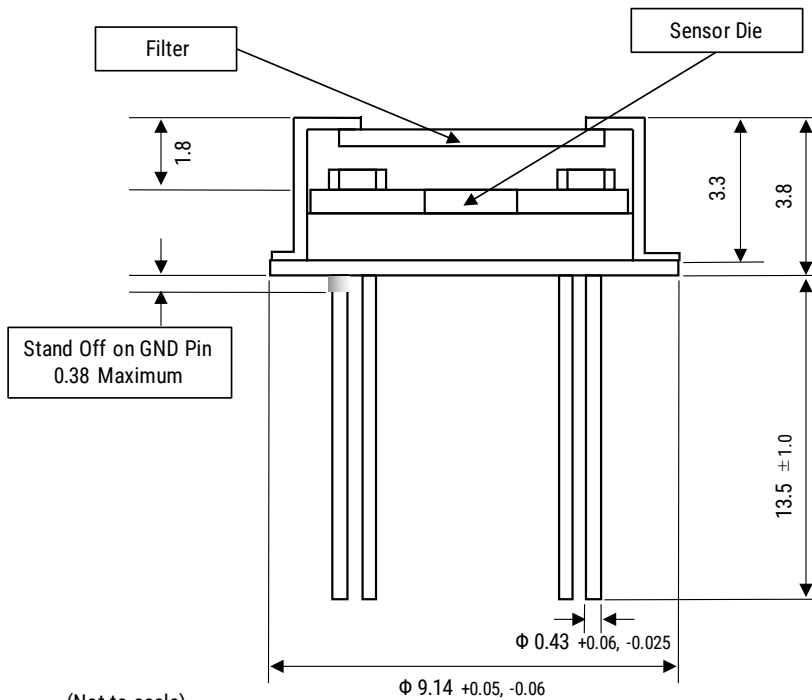

(Not to scale)  
Dimensions are typical, unless tolerance stated.

### Top View

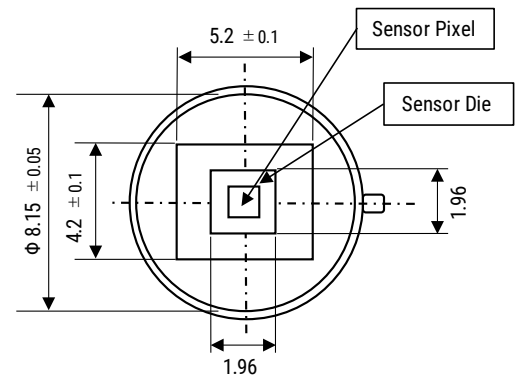

### Bottom View

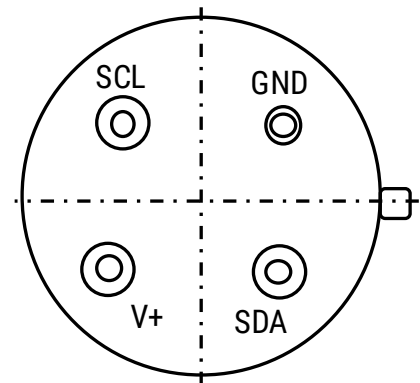

## Recommended Circuit Diagram

### Single Device Block Diagram

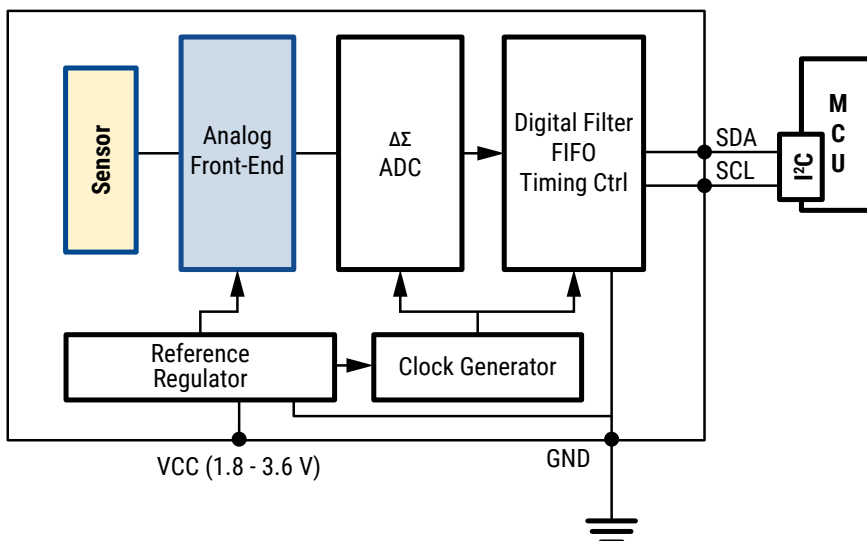

## Field of View

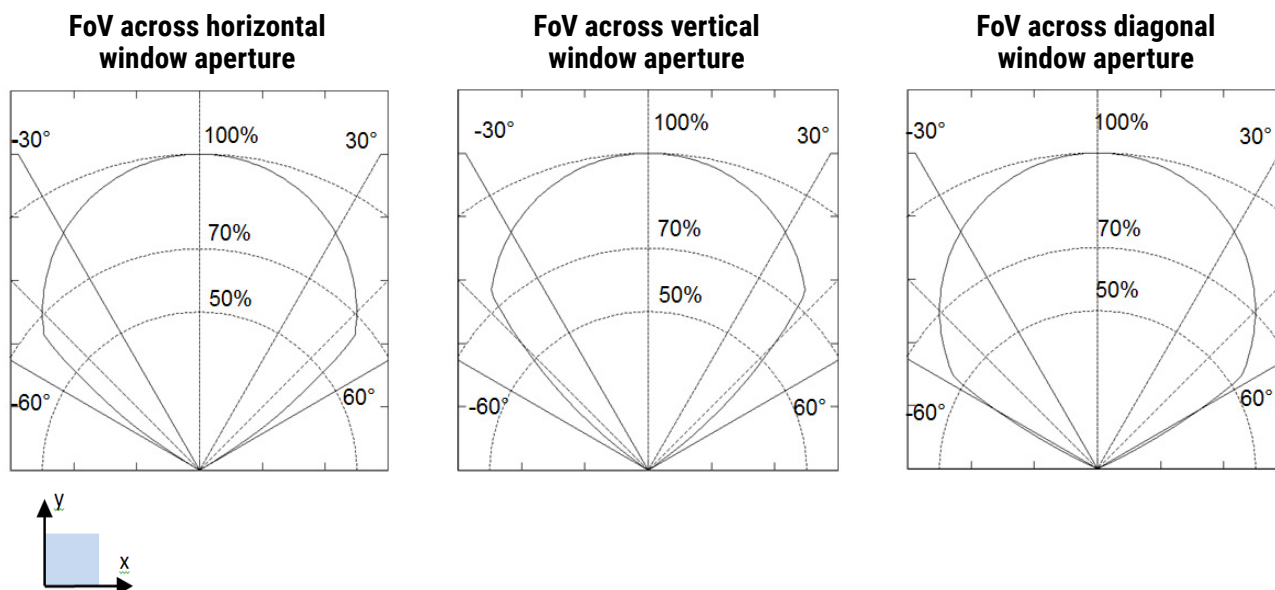

Note: Normalised polar plots show typical FoV along x, y axis and diagonal with 4.48  $\mu\text{m}$ /620 nm filter applied, with infrared source being a blackbody radiator at 500 K temperature.

## Performance Characteristics

### Power Modes

Item	Mode	Description	Typical Current Consumption (1.8 V, Room Temperature)
Power Consumption	Normal Power Mode	Normal power consumption, 1 kHz maximum sample rate	22 $\mu\text{A}$
	Low Power Mode	Low power consumption, 166 Hz maximum sample rate	3.5 $\mu\text{A}$

## Part Number Specifications

### Sensor Characteristics

Filter Aperture (mm)	Element Size (mm <sup>2</sup> )	Package	Time Constant (ms) at 10 – 20 Hz Peak	Field of View
5.2 x 4.2	1 x 1	T039	~10	~100°

### Electrical Characteristics

Supply Voltage (V)	Supply Current (μA) Typical	Digital I/O	ΔΣ ADC at 1 ksp	Operating Temperature Range (°C)	Storage Temperature Range (°C)	Sensor Read-out	Configurable
1.75 to 3.60	1 to 23	I <sup>2</sup> C (FM+ compatible)	15 – 23 bit	-40 to +85	-40 to +110	Current mode	Gain Digital filtering Sampling rate Power modes

### Part Number (Sensor)

Part Number	Filter Name	Cut On Wavelength (μm) Typical	Cut Off Wavelength (μm) Typical	Weight (gr)
USEQFCEA391100	3.91 μm bandpass	3.865	3.955	0.95
USEQFCEA448100	4.48 μm bandpass	4.170	4.790	0.95
USEQFCEA455100	4.55 μm bandpass	4.340	4.760	0.95
USEQFCEA500100	5.00 μm cut on	5.000	–	0.95

Filters block up to 8 μm.

## Evaluation Kits

- Quick prototype development
- Easy way to evaluate
- Easy to install software
- Digital output

The digital T0 Infrared Flame Sensing kit is to enable the users to carry out a simple and effective evaluation of the KEMET QFCE T0-39 packaged flame sensors, experiment with the sample flame detection ratio based algorithm, and to capture measured data to a PC. The kit is based on the ST microelectronics STM32F303K8 microcontroller with a high precision A-D converter and programmable gain amplifier.

Part Number	Use	Includes	Weight
 USEQFCK9000000	Digital T0 Flame Sensing Evaluation Kit	Flame Detection Demonstrator Kit Sensor USEQFCEA500100 5.00 μm Long Pass filter Sensor USEQFCEA391100 3.91 μm / 90 nm filter Sensor USEQFCEA448100 4.48 μm / 620 nm filter USB communications cable	360 gr

## Packaging

Part Number	Packaging Type	Pieces per Tube
USEQFCE*****	Tube	50

Part Number	Packaging Type	Pieces per Box
USEQFCK9000000	Cardboard Box	1

## Handling Precautions

Pyroelectric Infrared Sensors should be kept away from indirect and direct sunlight, the headlights of cars, wind, and exposure to strong vibration and strong shock.

Do not use in water, alcohol ETA, corrosive gas or under sea breeze.

Do not be expose to corrosive substances.

Do not drop or apply any mechanical stress.

The performance of this device can be affected by ESD. Precautions should be used when handling and installing the sensor. Precision devices such as this sensor can be damaged or caused not to meet published specification due to ESD. Please note that there is limited ESD protection built-in as the device is optimised for low power consumption and low noise operation. Human Body Model (HBM), per JS-001: 2,000 V.

Pyroelectric Infrared Sensors should be stored in normal working environments.

Solderability will be degraded by exposure to high temperatures, high humidity, corrosive atmospheres, and long-term storage.

KEMET recommends that ambient storage conditions are < 30°C and < 60% relative humidity and that maximum storage temperature does not exceed 110°C. Atmospheres should be free of chlorine and sulfur-bearing compounds.

Temperature fluctuations should be minimized to avoid condensation on the parts.

For optimized solderability sensors stock should be used promptly, preferably within 24 months of receipt.