

## Overview

KEMET's QGSM thin film digital pyroelectric IR sensor modules for gas detection and concentration measurement combine high sensitivity with fast response times and high dynamic range to ensure rapid and accurate detection of target gases.

The gas sensor modules consist of a breakout board, on which a SMD motion sensor is mounted, ideal for easy evaluation and quick prototype development. These sensors integrate a digital, current mode read-out that permits lower IR-emitter duty cycles, thereby saving significantly on system level power consumption, while maintaining high SNR. Industry standard I<sup>2</sup>C communication enables plug-and-play connectivity to microcontrollers and allows easy tuning and calibration. Programmable gain and filtering offer maximum flexibility in system design, and various optical filter options are also available. These sensors can be connected together in linear series to allow synchronized sampling across devices. For further in-depth testing of these gas sensing solutions, KEMET is proposing also an evaluation kit.

For additional sources of information, please refer to <https://ec.kemet.com/environmental-sensors/>

## Benefits

- High sensitivity with fast response time and high dynamic range
- Digital output and I<sup>2</sup>C communication
- Programmable gain and filtering
- Various optical filter options
- Integrated configurable amplifier, filter and ADC
- Low power consumption
- Sensor modules for easy evaluation and quick prototype development
- Evaluation kit for CO<sub>2</sub> gas sensing
- Easy to install and user-friendly software

## Applications

- Gas and gas flues
- HVAC (refrigerant or CO<sub>2</sub>-driven ventilation system)
- Industrial process and safety
- Medical capnography and anesthesia
- Handheld breath analysis and breath rate measurement
- Breath actuated dispenser
- Automotive cabin air quality
- Exhaust (CO<sub>2</sub> content)
- Home and building technology
- Environmental monitoring (ambient CO<sub>2</sub> level)
- Pollution air quality in home, office and car (excessive CO<sub>2</sub> level)

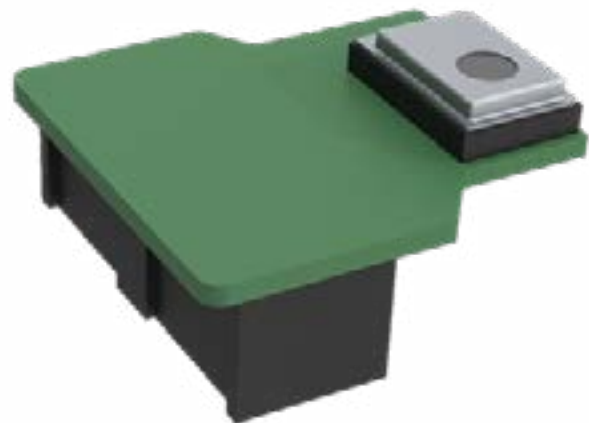

## Ordering Information

USE	QGS	E	A	C821	8	0
Product Family	Series	Sensor Type	Mounting Type	Specification	Packaging	Version
Sensors	QGS = SMD IR Gas Sensors	M = Serial module K = Evaluation kit	1 = Module type 1, low profile H = Module type 2, high profile 3 = Kit type 3	0000 = Fixed C821 = CO <sub>2</sub> CH41 = CH <sub>4</sub> N8L1 = NO 9501 = 9.50 μm	0 = Bulk	0

## Environmental Compliance

All KEMET Gas Sensors are RoHS and REACH Compliant.



Article 33(1) of the REACH Regulation states that manufacturers and importers of articles (products) are required to notify their customers of the presence of any Substances of Very High Concern (SVHC) in their products exceeding 0.1% by weight and provide instructions on safe use of the product.

KEMET Corporation reports regarding the Article 33(1) of REACH Regulation as follows:

1. *Applicable Product: Gas Sensors (QGC, QGS & QGSM series)*

2. *Report for the content of REACH SVHC list:*

*The product(s) above contains a substance by more than 0.1wt% per product weight that was published in the 8th update of the REACH SVHC substances (December 19, 2012).*

3. *Regarding the safety of the gas sensors (Piezoceramic products):*

*The Piezoceramic that is used in this product becomes ceramic by sintering powder containing PZT as the main ingredient. It is chemically stable, with minimum risks toward the human body or environment within the intended use of the product. Please note that risks could occur in the case of inhalation or accidental oral uptake of powder ceramics.*

4. *Technical product information on the gas sensors (Piezoceramic products):*

*The manufacturing technique of the “piezoceramic products” whose main ingredient is Lead Titanium Zirconium Oxide (PZT) has been established, and there is no alternative material that can exhibit superior performance than PZT at this moment. Please note that the piezoceramic is listed as an exempt on RoHS (2011/65/EU) AnnexIII (7c.1).*

5. *The responsibility of piezoceramic manufacturers:*

*Piezoceramic manufacturers report information regarding PZT containment in their products to the customers to obey the article 33 of the REACH regulation.*

## Infrared Spectroscopy

KEMET Infrared Sensors work in the MID Infrared Spectrum. They are a critical component -- but not the only component -- in a gas analysis system. An IR heat source and a suitable gas path “mechanical enclosure” are also required in order to complete the gas analysis system.

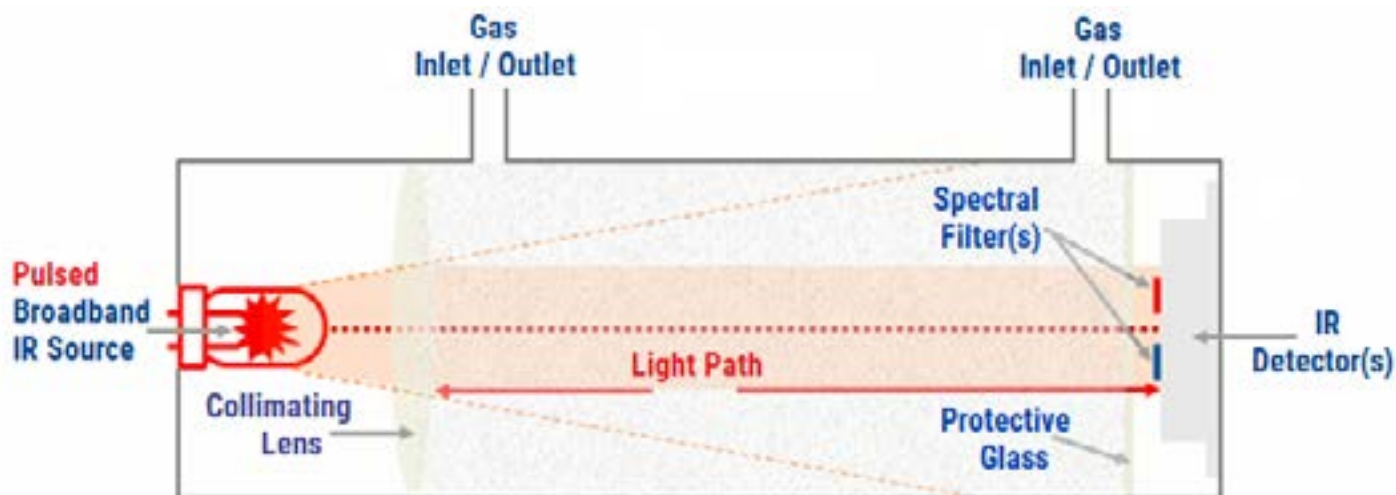

## IR Absorption - Active IR Sensing

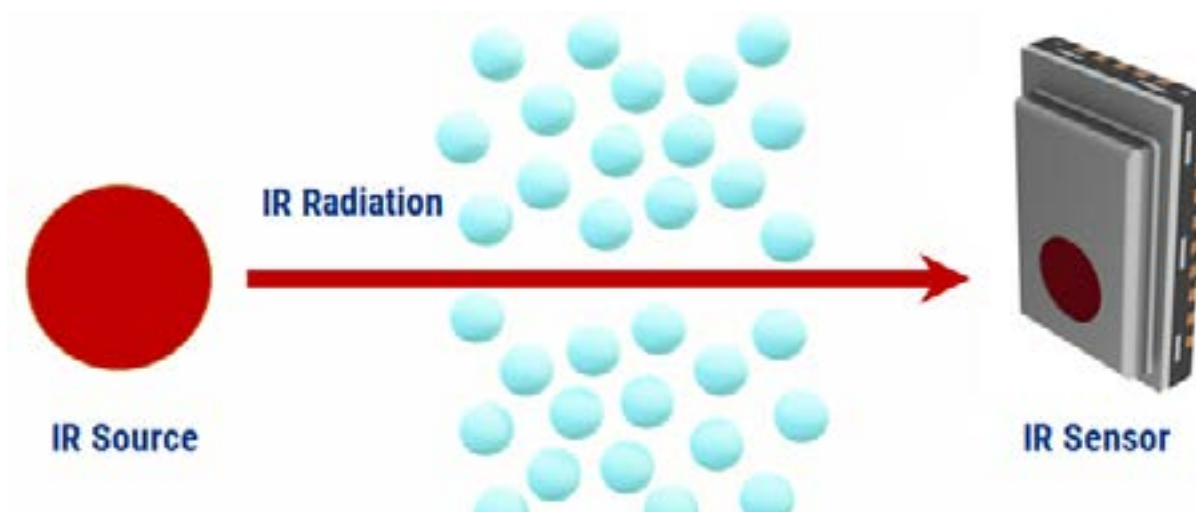

The IR source is directed as energy towards the sensor like an IR spotlight. Depending on the specific gas of interest or gas concentration levels between the IR source and the pyroelectric sensor, the IR transmitted is absorbed by the presence of the gas by a small amount. Understanding how much IR is being optically transmitted versus how much is received can indicate gas concentration levels.

Filters are used to shorten the optical spectrum of the sensor to specifically match the gas of interest. These filters are usually included within the sensor, but for special cases KEMET can make optimised filters to suit customers specific gas requirements.

## Dimensions – Millimeters

### Module

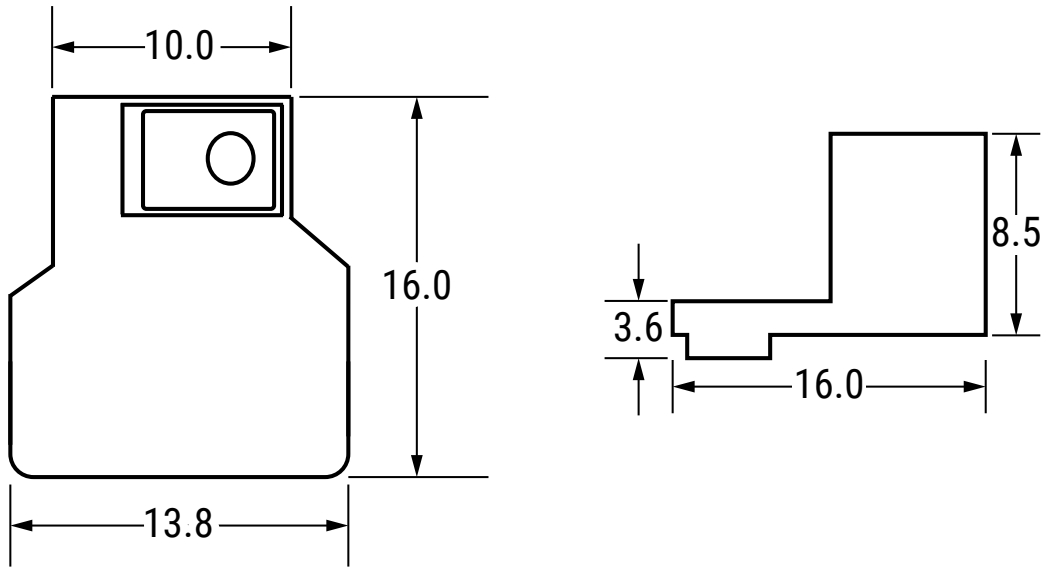

### Cable

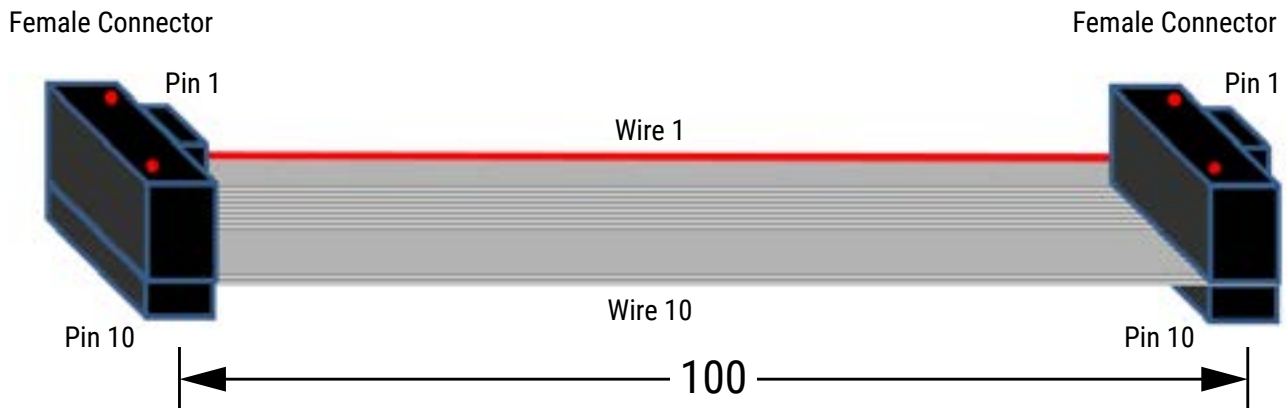

## Dimensions – Millimeters cont.

### Pin Configuration of the Module

Outfitted with all necessary components for the 1.8-3.6 V power supply of the device, all functionality of the sensor is routed out to a 10-pin 1.27 mm pitch IDC connector on the back side of the 16 x 13.8 mm PCB. The build height including the socket is 9 mm. They provide up to 1 MHz Fast Mode+ I<sup>2</sup>C communication to configure the sensor and read data from it.

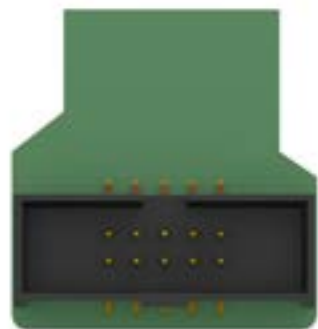

•9	•7	•5	•3	•1
•10	•8	•6	•4	•2

Pin	Symbol	Type
1	V <sub>supply</sub>	Power supply
2	Unassigned	-
3	SCL (I <sup>2</sup> C)	Digital in/out
4	SDA (I <sup>2</sup> C)	Digital in/out
5	CS	Digital in
6	INT	Digital out
7	SYNC	Digital in/out
8	CLK	Digital in/out
9	Unassigned	-
10	GND	Ground

There is a chip select/enable pin and an interrupt output available. The CLK/SYNC pins can be used to feed an external clock signal in to the board or, alternatively, distribute the clock signal of one board to several other boards, thereby creating a synchronized “network” of sensors.

## Field of View

USEQGSM1\*\*\*\*\* Low Profile

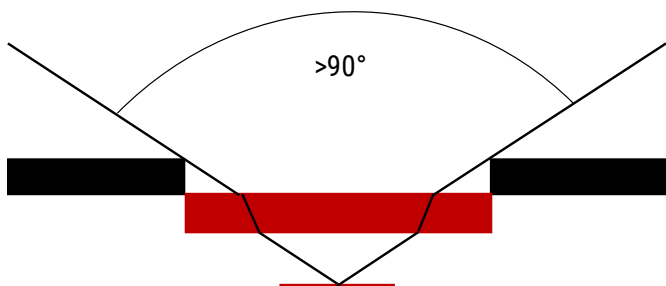

USEQGSMH\*\*\*\*\* High Profile

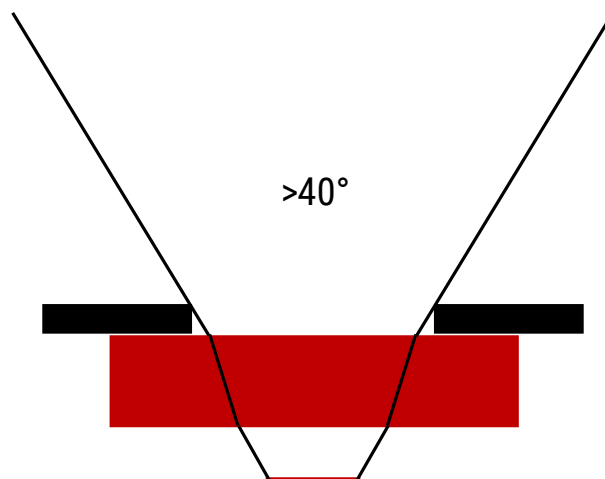

## Performance Characteristics

### Signal Filtering & Power Modes

Power Mode (base sample rate)	High Pass Filter – Analog (Hz)					Fixed Analog Low Pass Filter (Hz)	Fixed Digital Low Pass Filter (Hz)	Digital Low Pass Filter (Hz)				Maximum ADC Sampling Rate (sps)
	Off	1.0	2.0	4.0	8.0			180.0	90.0	45.0	22.5	
Normal Power Mode	Off	1.0	2.0	4.0	8.0	600	250	180.0	90.0	45.0	22.5	1,000
Low Power Mode	Off	0.17	0.33	0.66	1.30	100	42	30.00	15.00	7.50	3.75	166

Item	Mode	Description	Typical Current Consumption (1.8 V, room temperature)
Power consumption	Normal Power Mode	Normal power consumption, 1 kHz maximum sample rate	22 $\mu$ A
	Low Power Mode	Low power consumption, 166 Hz maximum sample rate	3.5 $\mu$ A
Operational state	Normal Operation Mode	Sensor signal readout over I <sup>2</sup> C	22 $\mu$ A
	Sleep Mode	Hardware interrupt on infrared trigger	21 $\mu$ A (Normal Power Mode) 3.5 $\mu$ A (Low Power Mode)
	Power Down Mode	Sensor is disabled	1.1 $\mu$ A

### Infrared Frequency Characteristics

Typical Frequency Response in Normal Power Mode

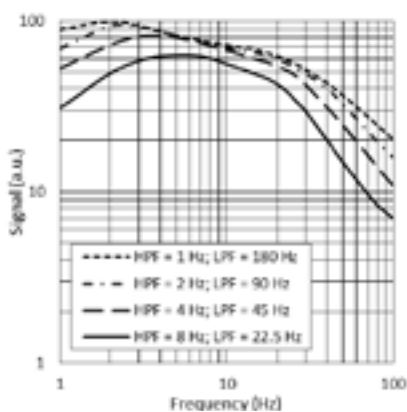

Typical Frequency Response in Low Power Mode

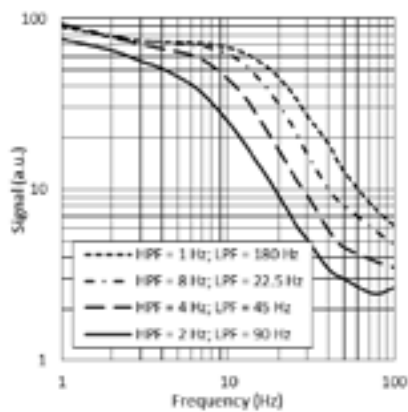

Typical Frequency Response at Different Gain Settings

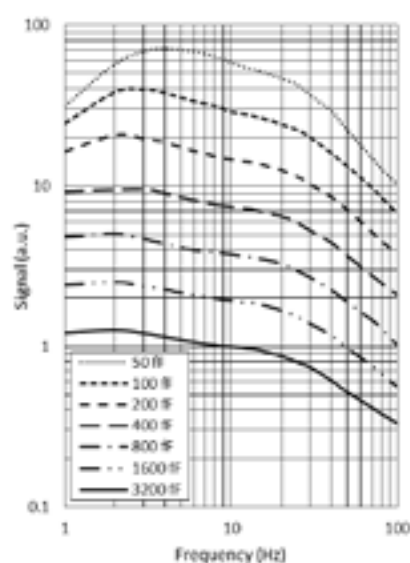

## Part Number Specifications

### Sensor Characteristics

Filter Aperture (mm)	Element Size (mm <sup>2</sup> )	SMD Package (mm)	D* <sup>1</sup> (cm√Hz/W) Typical	NEP <sup>1</sup> (W/√Hz) Typical	Time Constant (ms) at 10-20 Hz peak	Field of View
φ 1.65	0.64 x 0.64	5.65 x 3.70 x 1.55	2.5 x 10 <sup>8</sup>	2.7 x 10 <sup>-10</sup>	~10	~90°

<sup>1</sup> 10 Hz, 500 K, room temperature, without window and optics.

### Electrical Characteristics

Supply Voltage (V)	Supply Current (μA) Typical	Digital I/O	ΔΣ ADC at 1 ksp	Operating Temperature Range (°C)	Storage Temperature Range (°C)	Sensor Read-out	Configurable
1.75 to 3.60	1 to 23	I <sup>2</sup> C (FM+ compatible)	15 bit	-40 to +85	-40 to +110	Current mode	Gain Digital filtering Sampling rate Power modes

### Part Number (Module)

Part Number	Including Sensor	Filter (μm)	Filter BW (nm)	Use	Weight (gr)
USEQGSM1C82100	USEQGSEAC82180	4.26	180	CO <sub>2</sub>	5.40
USEQGSM1CH4100	USEQGSEACH4180	3.30	160	CH <sub>4</sub>	5.40
USEQGSM1N8L100	USEQGSEAN8L180	5.30	180	NO	5.40
USEQGSMH950100	USEQGSEH950180	9.50	400	Sugar, Ethanol	5.41

Below flame sensors from the QFS series can also be used for gas detection or analysis, more details about these products available on

[https://content.kemet.com/datasheets/KEM\\_SE0218\\_QFSM.pdf](https://content.kemet.com/datasheets/KEM_SE0218_QFSM.pdf)

Part Number	Including Sensor	Filter (μm)	Filter BW (nm)	Use	Weight (gr)
USEQFSM1391100	USEQFSEA391180	3.91	90	Reference	5.40
USEQFSM122L100	USEQFSEA22L180 <sup>1</sup>	2.20	Long pass	Broadband	5.40
USEQFSM150L100	USEQFSEA50L180 <sup>1</sup>	5.00	Long pass	Broadband	5.40
USEQFSM1464100	USEQFSEA464180 <sup>2</sup>	4.64	180	CO	5.40

<sup>1</sup> Used with bespoke, customer or application-specific (narrowband) filters mounted externally.

<sup>2</sup> Used as gas or active filter.

## Evaluation Kits

### Control Board for Module

Part Number	Use	Includes	Weight
USEQCSK0000000	Control Board for Modules	Preassembled backplane PCB USB communications cable Ribbon cable, optional use (up to 4)	250 gr

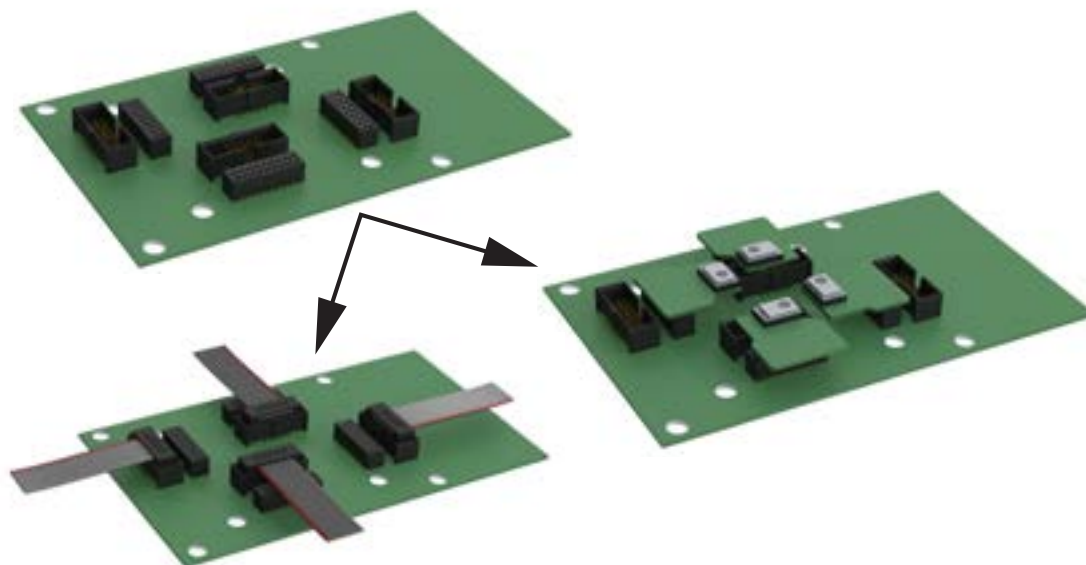

USEQCSK0000000 can flexibly host up to four modules. With no hardware design work required, a combination of this backplane board and any of the attached SMD sensors can produce infrared sensor signal measurements out of the box in the early evaluation and design stages. This control board is provided with PC software allowing the user to configure and read out each of the SMD sensors connected. The sensor data is visualised in real time on a scope plot in the user interface. A csv file capture facility records the digital signals from the sensors for further processing by the user.

### Evaluation Kits

- Quick prototype development
- Easy way to evaluate
- Easy to install software
- Digital output

The digital SMD CO<sub>2</sub> Gas Sensing Evaluation Kit is to enable engineers and technicians to carry out a simple and effective evaluation of the QGS SMD sensors, to capture measured data and send it to a PC.



## Evaluation Kits cont.

Part Number	Use	Includes	Weight (gr)
USEQGSK3000000	SMD CO <sub>2</sub> Gas Sensing Evaluation Kit	PCB with STM32F303K8T6 microcontroller USEQFSEA391180, 1 px 3.91 μm / 90 nm USEQGSEAC82180, 1 px 4.26 μm / 180 nm Emitter drive PCB, with T039 IR emitter 3D printed gas cell 9 V DC power supply USB communications cable	300



## Packaging

Part Number	Packaging Type	Pieces Per Bag
USEQMSM*****	ESD Protective Bag	1

Part Number	Packaging Type	Pieces Per Box
USEQCSK0000000	Cardboard Box	1
USEQGSK3000000		

## Handling Precautions

Pyroelectric Infrared Sensors should be kept away from indirect and direct sunlight, the headlights of cars, wind, and exposure to strong vibration and strong shock.

Do not use in water, alcohol ETA, corrosive gas or under sea breeze.

Do not expose to corrosive substances.

Do not drop or apply any mechanical stress.

The performance of this device can be affected by ESD. Precautions should be used when handling and installing the sensor. Precision devices such as this sensor can be damaged or caused not to meet published specification due to ESD. Please note that there is limited ESD protection built-in as the device is optimised for low power consumption and low noise operation. Human Body Model (HBM), per JS-001: 2,000 V.

Pyroelectric Infrared Sensors should be stored in normal working environments. Do not expose to high temperatures, high humidity, corrosive atmospheres, and avoid long-term storage. KEMET recommends that ambient storage conditions are <30°C and <60% relative humidity and that maximum storage temperature does not exceed 110°C. Atmospheres should be free of chlorine and sulfur-bearing compounds.

Temperature fluctuations should be minimized to avoid condensation on the parts. The stock of sensors should be used promptly, preferably within 24 months of receipt.