

**GLASS PASSIVATED SUPER FAST RECTIFIER**  
**VOLTAGE RANGE 50 to 200 Volts CURRENT 3.0 Amperes**

**USF31  
THRU  
USF34**

**FEATURES**

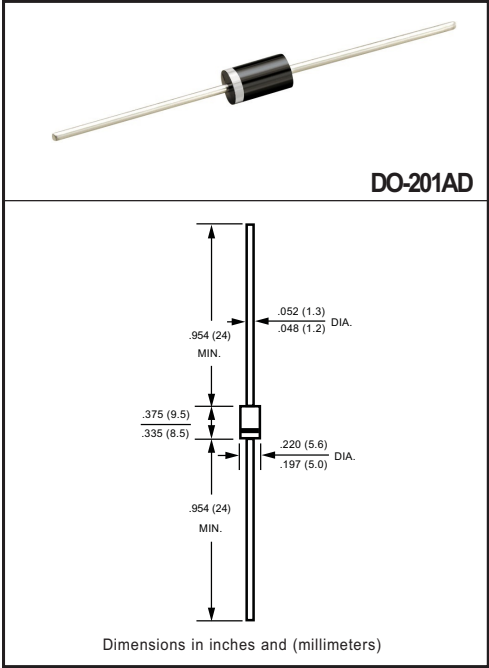
- \* Glass passivated device
- \* For surface mounted applications
- \* Ultrafast recovery times dor high efficiency
- \* Low forward voltage, low power loss
- \* Low leakage current

**MECHANICAL DATA**

- \* Epoxy: Device has UL flammability classification 94V-O
- \* Metallurgically bonded construction
- \* Mounting position: Any

**MAXIMUM RATINGS AND ELECTRICAL CHARACTERISTICS**

Ratings at 25 °C ambient temperature unless otherwise specified.  
 resistive or inductive load.



**MAXIMUM RATINGS (@ TA=25 °C unless otherwise noted)**

RATINGS	SYMBOL	USF31	USF32	USF33	USF34	UNITS
Maximum Recurrent Peak Reverse Voltage	V <sub>RRM</sub>	50	100	150	200	Volts
Maximum RMS Voltage	V <sub>RMS</sub>	35	70	105	140	Volts
Maximum DC Blocking Voltage	V <sub>DC</sub>	50	100	150	200	Volts
Maximum Average Forward Rectified Current at T <sub>A</sub> = 55°C	I <sub>O</sub>	3.0				Amps
Peak Forward Surge Current 8.3 ms single half sine-wave superimposed on rated load (JEDEC method)	I <sub>FSM</sub>	80				Amps
Current Squarad Time	I <sup>2</sup> t	26.56				A <sup>2</sup> /Sec
Typical Thermal Resistance (Note 1)	R <sub>θJA</sub>	20				°C/W
Typical Thermal Resistance (Note 1)	R <sub>θJL</sub>	8.0				°C/W
Typical Junction Capacitance (Note 2)	C <sub>J</sub>	45				pF
Operating Temperature Range	T <sub>J</sub>	-55 to + 150				°C
Storage Temperature Range	T <sub>STG</sub>	-55 to + 150				°C

**ELECTRICAL CHARACTERISTICS (@TA=25 °C unless otherwise noted)**

CHARACTERISTICS	SYMBOL	USF31	USF32	USF33	USF34	UNITS
Maximum Instantaneous Forward Voltage at 3.0A DC	V <sub>F</sub>	.95				Volts
Maximum Average Reverse Current at Rated DC Blocking Voltage	@T <sub>A</sub> = 25°C	5.0				μA
	@T <sub>A</sub> = 150°C	2.0				mA
Maximum Reverse Recovery Time (Note 4)	t <sub>rr</sub>	20				nSec

- NOTES :
1. Thermal Resistance :At 9.5mm lead lengths, PCB mounted.
  2. Measured at 1 MHz and applied reverse voltage of 4.0 volts.
  3. " ROHS compliant".
  4. Test Conditions: I<sub>F</sub>= 0.5A, I<sub>R</sub>= -1.0A, I<sub>RR</sub>= -0.25A.

## RATING AND CHARACTERISTICS CURVES ( USF31 THRU USF34 )

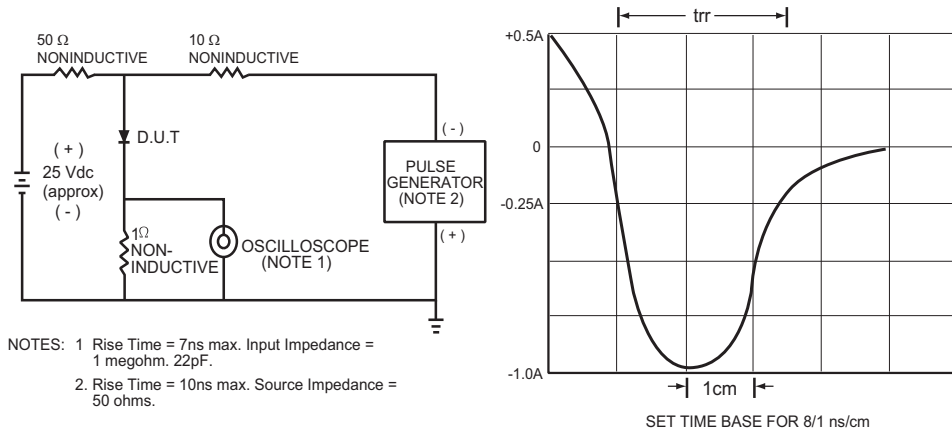


FIG.1 TEST CIRCUIT DIAGRAM AND REVERSE RECOVERY TIME CHARACTERISTIC

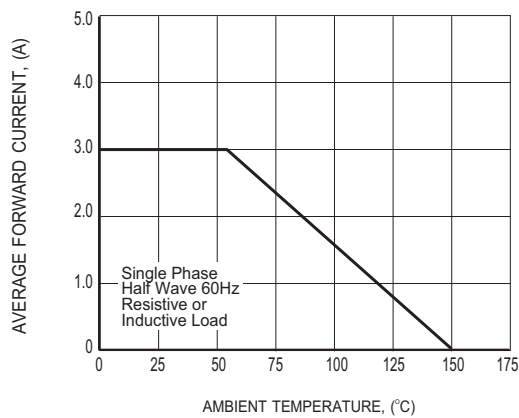


FIG.2 TYPICAL FORWARD CURRENT DERATING CURVE

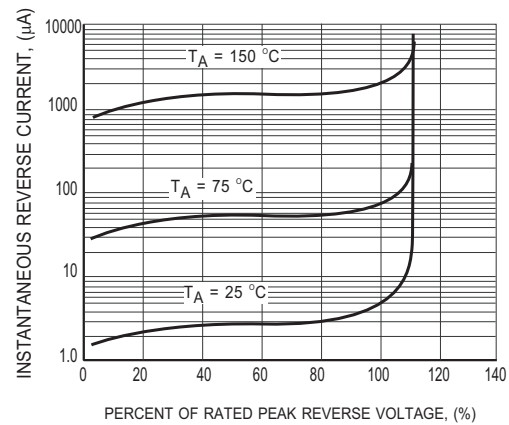
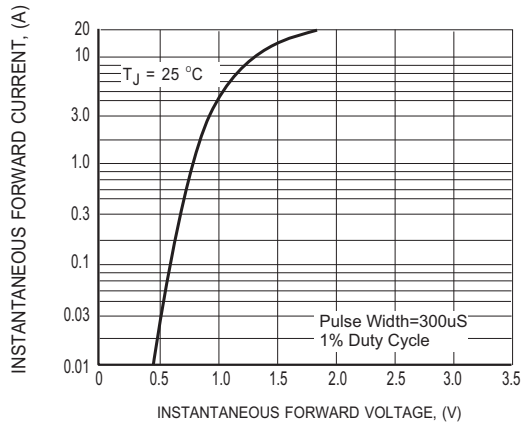
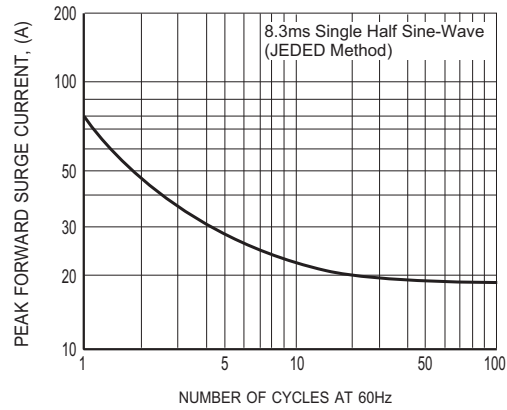


FIG.3 MAXIMUM REVERSE CHARACTERISTICS

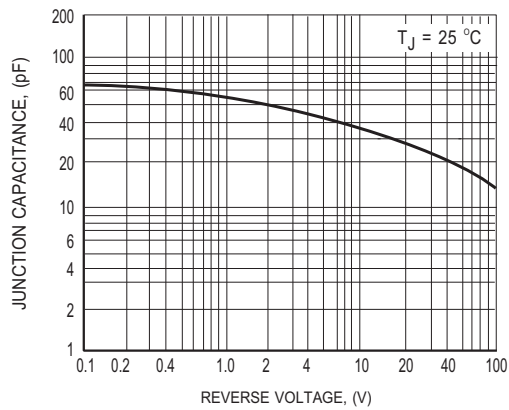
## RATING AND CHARACTERISTICS CURVES ( USF31 THRU USF34 )



**FIG.4 MAXIMUM INSTANTANEOUS FORWARD CHARACTERISTICS**

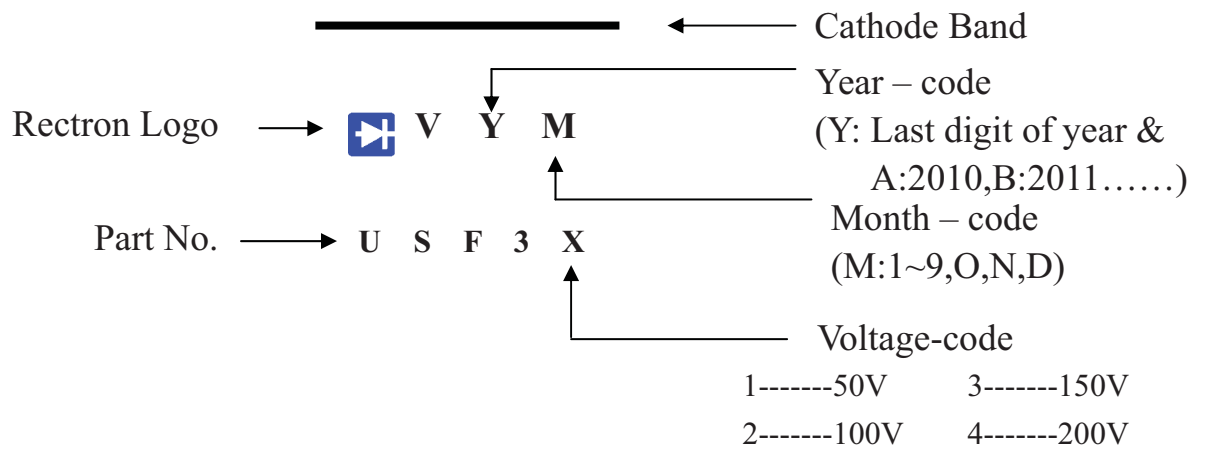


**FIG.5 MAXIMUM NON-REPETITIVE FORWARD SURGE CURRENT**



**FIG.6 TYPICAL JUNCTION CAPACITANCE**

## Marking Description



## PACKAGING OF DIODE AND BRIDGE RECTIFIERS

### BULK PACK

PACKAGE	PACKING CODE	EA PER BOX	INNER BOX SIZE (mm)	CARTON SIZE (mm)	EA PER CARTON	GROSS WEIGHT(Kg)
DO-201	-B	500	300*73*40	347*320*271	12,000	15.9

### REEL PACK

PACKAGE	PACKING CODE	EA PER REEL	EA PER INNER BOX	COMPONENT SPACE (mm)	TAPE SPACE (mm)	REEL DIA (mm)	CARTON SIZE (mm)	EA PER CARTON	GROSS WEIGHT(Kg)
DO-201	-T	1,200	1,200	5.0	52	330	355*350*335	4,800	9.10

### AMMO PACK

PACKAGE	PACKING CODE	REEL ( EA )	COMPONENT SPACE(mm)	TAPE SPACE (mm)	BOX SIZE (mm)	CARTON SIZE(mm)	CARTON ( EA )	GROSS WEIGHT (Kg)
DO-201	-F	600	9.5	52	255*73*100	400*268*225	6,000	9.9