



Reference Manual

Mpression Vx1 FMC Card

Revision 1.0

2016/11/02

© 2016 Macnica, Inc.

Disclaimer

The information in this document (hereinafter called “Information”) is subject to change without notice.

Macnica Inc. (Developer) makes no warranty of any kind regarding this document, or of any liability arising out of the application or use of information in this document, and assumes no responsibility for any errors that may appear in this document.

This document is distributed without any charge and reselling or copying without written authorization by Developer is restricted.

IN NO EVENT WILL DEVELOPER BE LIABLE FOR ANY CONSEQUENTIAL, INDIRECT, EXEMPLARY, SPECIAL, OR INCIDENTAL DAMAGES, INCLUDING ANY LOST DATA AND LOST PROFITS, ARISING FROM OR RELATING TO YOUR USE OF THE INFORMATION, EVEN IF YOU HAVE BEEN ADVISED OF THE POSSIBILITY OF SUCH DAMAGES. THE TOTAL CUMULATIVE LIABILITY OF DEVELOPER IN CONNECTION WITH YOUR USE OF THE INFORMATION IN THIS DOCUMENT, WHETHER IN CONTRACT OR TORT OR OTHERWISE, WILL IN NO EVENT EXCEED THE AMOUNT OF FEES PAID BY YOU TO DEVELOPER HEREUNDER FOR USE OF THE INFORMATION. YOU ACKNOWLEDGE THAT THE FEES, IF ANY, REFLECT THE ALLOCATION OF RISK SET FORTH IN THIS AGREEMENT AND THAT DEVELOPER WOULD NOT MAKE AVAILABLE THE INFORMATION TO YOU WITHOUT THESE LIMITATIONS OF LIABILITY.

The Information is not intended for use in the development of on-line control equipment in hazardous environments requiring failsafe controls, such as in the operation of nuclear facilities, aircraft navigation or communications systems, air traffic control, life support, or weapons systems (“High-Risk Applications”). Developer specifically disclaims any express or implied warranties of fitness for such High-Risk Applications. You represent that use of the Information in such High-Risk Applications is fully at your risk.

Contents

1. Read This First	4
1.1 Important Information	4
1.2 Developer Information	5
1.3 Inquires	5
2. For Ensuring Safe Use	6
2.1 Legend	6
2.2 Cautions	6
3. Unpacking	9
4. Functions and Features of This Board	10
4.1 Main Features	10
4.2 Product Specifications	10
4.3 Block Diagram	11
4.4 Board Specification	12
4.4.1 Connector Layout	12
4.4.2 Component Layout	13
4.4.3 Switch and LED Layout and Specifications	14
5. Hardware Specifications	15
5.1 Connector Pin Assignments	15
5.2 Differential Clock Generator	18
5.3 Jitter Attenuator	18
5.4 Power Tree	19
6. Document Revision History	20

1. Read This First

1.1 Important Information

READ FIRST:

- **READ** this Reference Manual before using this product.
- **KEEP** the Reference Manual handy for future reference.
- **Do not attempt** to use the product until you fully understand its mechanism.

Purpose of the Product:

- This product supports development and evaluation of a system that uses Altera Corporation's FPGA. It provides support for system development in both software and hardware. Be sure to use this product correctly for this purpose.

For Users of This Product:

- This product can only be used by operators who have carefully read and understand this manual and "Getting Started". Use of this product requires a basic knowledge of FPGAs, logic circuits, electric circuits, and microcomputers.

Precautions to be taken when using This Product:

- This product is to be used for development of a program, and the evaluation stage. You cannot install this Board in your product and cannot use this Board for mass-production. When mass-producing a program you have finished developing, be sure to decide at your own responsibility whether it can be put to practical use by performing integration test, evaluation, or some other experiment.
- In no event shall Macnica Inc. be liable for any consequence arising from the use of this product.
- Macnica Inc. shall make effort to provide a workaround or fix for failures of this product, with or without charge. This does not mean, however, that Macnica Inc. guarantees to provide a workaround or fix under all circumstances.
- Macnica Inc. cannot anticipate every possible circumstance that might involve a potential hazard. The warnings in this reference manual and on the product are therefore not all-inclusive. Use this product correctly and safely at your own responsibility.
- Even if a device installed on this product has a failure, it cannot be replaced.
- Not all types of apparatus are guaranteed to connect with V-by-One HS interface.
- Remodeling or damages caused by the customer is not guaranteed.
- This product is a lead-free mounting product.
- Generally, the brand names carried in this reference manual each constitute a maker's trademark or registered trademark.

Improvement Policy:

- Macnica Inc. pursues a policy of continuous improvement in design, performance, and safety of the product. Macnica Inc. reserves the right to change, wholly or partially, specifications, design, reference manual, and other documentation at any time without notice.

Warranty:

- Macnica Inc. offers exchange of this product free of charge only in a set range of cases of initial trouble for this product, and within 30 days from when the customer received delivery of the Board.

Macnica Inc. cannot exchange products in cases where breakdown is caused for the following reasons:

- (1) Misuse, abuse of the product or use under abnormal conditions
- (2) Remodeling or repair
- (3) A fire, earthquake, fall or other accidents

Figures:

- Some figures in this reference manual may differ from your system as purchased.

1.2 Developer Information

The Developer of this product is:

Macnica Inc.

1-6-3 Shin-Yokohama, Kouhoku-ku, Yokohama, 222-8561 JAPAN

1.3 Inquires

In case you have any inquiries about the use this product, please contact your local Macnica company or make inquiries through the contact form in the following web site:

Mpression brand web site inquiry page:

<http://www.m-pression.com/contact>



Macnica companies:

- | | | |
|------------------|-----------------------|---------------------------------------------------------------------------------|
| • China & HK: | Cytech Technology | http://www.cytech.com/ |
| • ASEAN & India: | Cytech Global | http://www.cytechglobal.com/ |
| • Taiwan: | Galaxy Far East Corp. | http://www.gfec.com.tw/ |
| • North America: | Macnica Americas | http://www.macnica-na.com/ |
| • Brazil: | Macnica DHW | http://www.macnicadhw.com.br/en/ |
| • Japan: | Altima | http://www.altima.co.jp |
| | Elsena | http://www.elsena.co.jp |

2. For Ensuring Safe Use



Be sure to follow the instructions given in this Manual which are intended to prevent harm to the user and others as well as material damage.



2.1 Legend

 Danger	Indicates an imminent hazardous situation which if not avoided will result in death or serious injury.
 Warning	Indicates a potentially hazardous situation which if not avoided could result in death or serious injury.
 Caution	Indicates a potentially hazardous situation which if not avoided may result in minor or moderate injury or in property damage.

- **Note: Important** is used to communicate exceptional conditions or cautions to users in operation procedures or explanatory descriptions.

2.2 Cautions

 Danger	<p>Make sure to use the AC adapter (included in the package) that meets the specification described in this manual.</p> <p>Using an AC adapter not meeting the specifications described in this Manual may cause the kit to emit heat, explode, or ignite.</p>
 Warning	<p>Do not apply strong impacts or blows to the kit.</p> <p>Doing so may cause the kit to emit heat, explode, or ignite, or the equipment in the kit to fail or malfunction. This may also cause fire.</p>
	<p>Do not put the main unit or the AC adapter in cooking appliances such as microwave ovens, or high-pressure containers. Doing so might cause the main unit or AC adapter to emit heat, explode, ignite, or emit smoke, or its parts to break or warp.</p>
	<p>Do not wrap the main unit that is in use with cloth or other materials that are likely to allow heat to build up inside the wrapping.</p> <p>This will cause heat to build up inside the wrapping which may cause the main unit to ignite or malfunction.</p>
	<p>When disposing of the main unit, do not dispose of it along with general household waste.</p> <p>Throwing the main unit into fire may cause it to explode. Dispose of the main unit following the laws, regulations, and ordinances governing waste disposal.</p>
	<p>Do not pull the power supply cable with excessive force or place heavy items on it.</p> <p>Do not damage, break, bundle, or tamper with the power supply cable.</p> <p>Damaged parts of the power supply cable might cause a short circuit resulting in fire or accidents involving electrical shock.</p>
	<p>Do not plug or unplug the power plug with wet or moist hands.</p> <p>This might cause injuries or equipment malfunctions or failures due to electrical shock.</p>

 <p>Warning (Continued from previous page)</p>	<p>Plug the power plug securely into the outlet. If the power plug is not securely plugged into the outlet, it may cause accidents involving electrical shock or fire due to heat emitted.</p> <p>Do not connect many electrical cords to a single socket or connect an AC adapter to an outlet that is not rated for the specified voltage. Doing so may cause the equipment to malfunction or fail, or lead to accidents involving electrical shock or fire due to heat emitted.</p> <p>Periodically remove any dust accumulated on the power plug and around the outlet (socket). Do not use a power plug with dust accumulated on it because doing so will lead to insulation failure due to moisture which may lead to fire. Remove any dust on the power plug and around the outlet with dried cloth.</p> <p>Do not place any containers such as cups or vases filled with water or other liquid on this Board. If this Board is exposed to water or other liquid it may cause the Board to malfunction or lead to accidents involving electrical shock. If you spilled water or other liquid on this Board, immediately stop using the Board, turn off the power, and unplug the power plug. If you have any requests for repairs or technical consultation, please contact the local Macnica company or Mpression inquiry URL.</p> <p>Keep this board and accessories out of reach of children. Failure to do so may lead to injuries.</p>
 <p>Caution</p>	<p>Do not place the kit on unstable places such as shaky stands or tilted locations. Doing so may cause injuries or cause this Board to malfunction if the Board should fall.</p> <p>Do not attempt to use or leave the kit in places subject to strong direct sunlight or other places subject to high temperatures such as in cars in hot weather. Doing so might cause the kit to emit heat, break, ignite, run out of control, warp, or malfunction. Also, some parts of the equipment might emit heat causing burn injuries.</p> <p>Do not use the kit in places subject to extremely high or low temperatures or severe temperature changes. Doing so may cause the kit to fail or to malfunction. Always be sure to use the kit within a temperature range of 5°C to 35°C and a humidity range of 0% to 85%.</p> <p>Unplug the power supply cable when carrying out maintenance of devices in which the main unit is embedded. Failure to do so may lead to accidents involving electrical shock.</p> <p>Do not place this Board in locations where excessive force is applied to the Board. Doing so may cause the PC board to warp, leading to breakage of the PC board, missing parts or malfunctioning parts.</p> <p>When using the kit together with expansion boards or other peripheral devices, be sure to carefully read each of their manuals and to use them correctly. Developer does not guarantee the operation of specific expansion boards or peripheral devices when used in conjunction with this Board unless they are specifically mentioned in this Manual or their successful operation with this Board has been confirmed in separate documents.</p>

 <p>Caution (Continued from previous page)</p>	<p>Be sure to turn off the power switch when moving this Board to connect to other devices. Failure to do so may cause this Board to fail or lead to accidents involving electrical shock.</p>
	<p>Do not clean this Board by using a rag containing chemicals such as benzene or thinner. Failure to do so will likely to cause this Board to deteriorate. When using a chemical cloth be sure to comply with any directions or warnings.</p>
	<p>Do not immediately turn on the power if you find that water or moisture had condensed onto the main unit after removing the board from the package. Condensation might occur on this Board when taking it out of the box, if the board is cool yet the room temperature is warm. Do not apply power to the Board while water or moisture has condensed on it because the moisture may cause the Board to break or may shorten the service life of the parts. When you first take this Board out of the box be sure to leave it at room temperature for a while before using it. If condensation or moisture has occurred on this Board, first wait for the moisture to fully evaporate before installing or connecting the Board to other devices.</p>
	<p>Do not disassemble, dismantle, modify, alter, or recycle parts unless they are clearly described as customizable in this Manual. Although this Board is customizable, if parts not specified in this Manual as customizable are modified in any way, then the overall product operation cannot be guaranteed. Please contact the local Macnica company or Mpression inquiry URL beforehand if you wish to customize or modify any parts that are not described in this Manual as customizable.</p>

3. Unpacking

During unpacking, check to make sure that all required items are included, and that nothing is damaged.

If something is missing or visibly damaged, contact Macnica within 30 days after receiving your purchase.

Customer letter	
Vx1 FMC Card	
Board Spacer	
Vx1 FMC Card Reference Manual	To download these files, go to the URL noted on the letter.
Vx1 FMC Card Circuit Diagram	
Vx1 FMC Card Cables (30 cm): 4	
Vx1 FMC Card Sample Design	
Vx1 FMC Card Getting Started	

4. Functions and Features of This Board

4.1 Main Features

This Board has a built-in Samtec FMC connector (High-Pin Count) and HRS FX16 connector (51 pins), and supports THine Electronics V-by-One HS transmission.

- FMC LPC and FMC LPC+ compatible
- 148.5 MHz reference clock for an Altera FPGA transceiver
- External reference clock support via the SMP connector for an FPGA transceiver
- Hirose FX16 connector (51 pins) allows connection of a compatible FFC cable
- Built-in jitter attenuator

	Important
	Note that this Board is designed exclusively for 1.8 V supply voltage from the FMC connector VADJ pin. Use of 2.5 V or 3.3 V is not supported.

4.2 Product Specifications

Table 4-1 shows the product specifications of this Board.

Table 4-1 Product Specifications

Item	Components or Specifications
Power Supply	3.3 V (3P3V), 1.8 V (VADJ)
External Dimensions	69.0 mm x 106.5 mm
PCB	FR4 10 layers
FMC Connector	ASP-134488-01
FX16 Connector	FX16M2-51S-0.5SH
SMP Connector	SMP-PS-P-GF-ST-TH2
Clock	Si5335
Jitter Attenuator	Si5317
Level shifter	SN74AVC4T245PWR

4.3 Block Diagram

Figure 4-1 shows the block diagram of this Board.

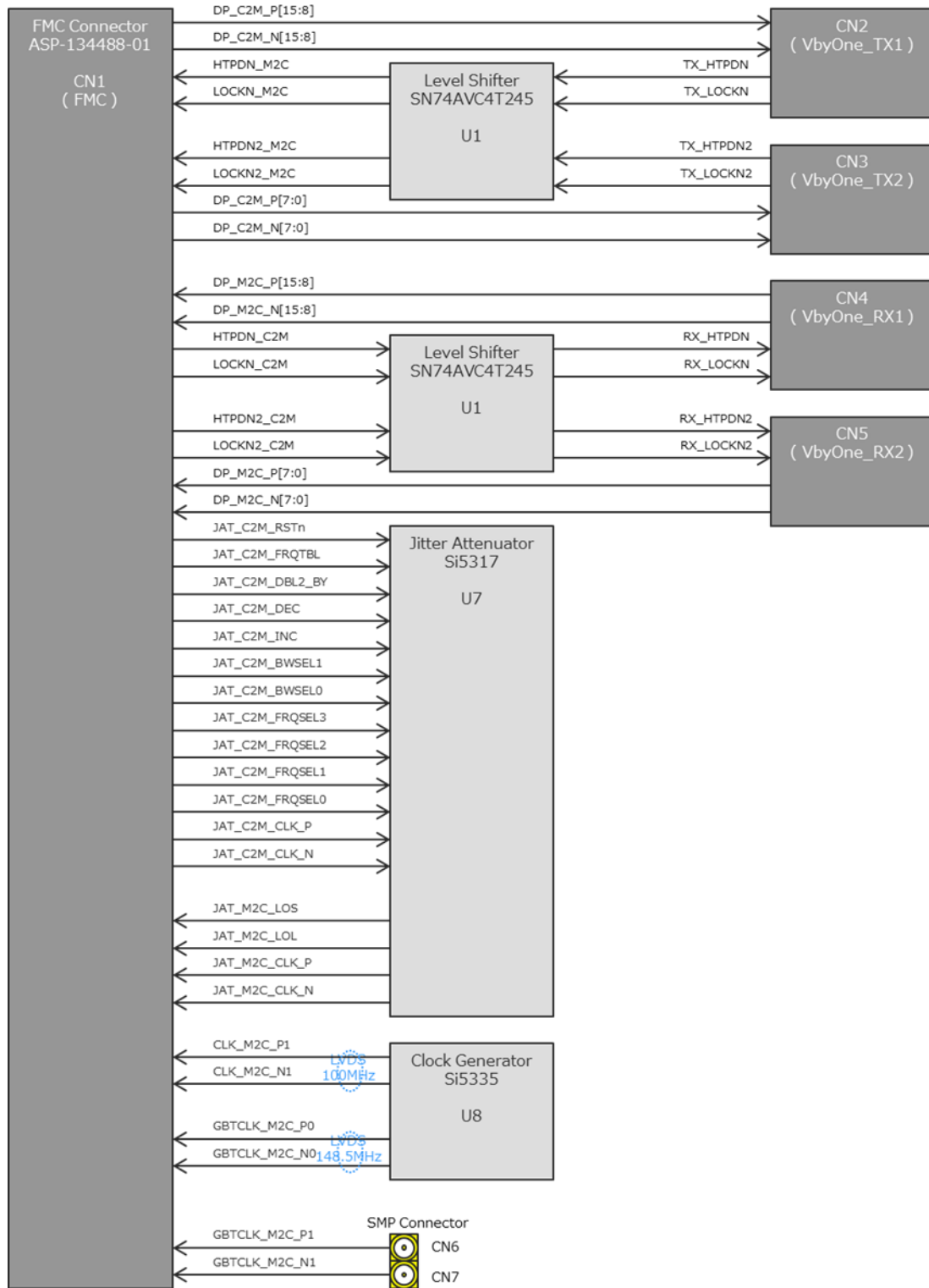

Figure 4-1 Block Diagram

4.4 Board Specification

This section explains the layout of the connectors, components, switches, and LEDs of this Board.

4.4.1 Connector Layout

Figure 4-2 and Table 4-2 show the layout of connectors and components on this Board.

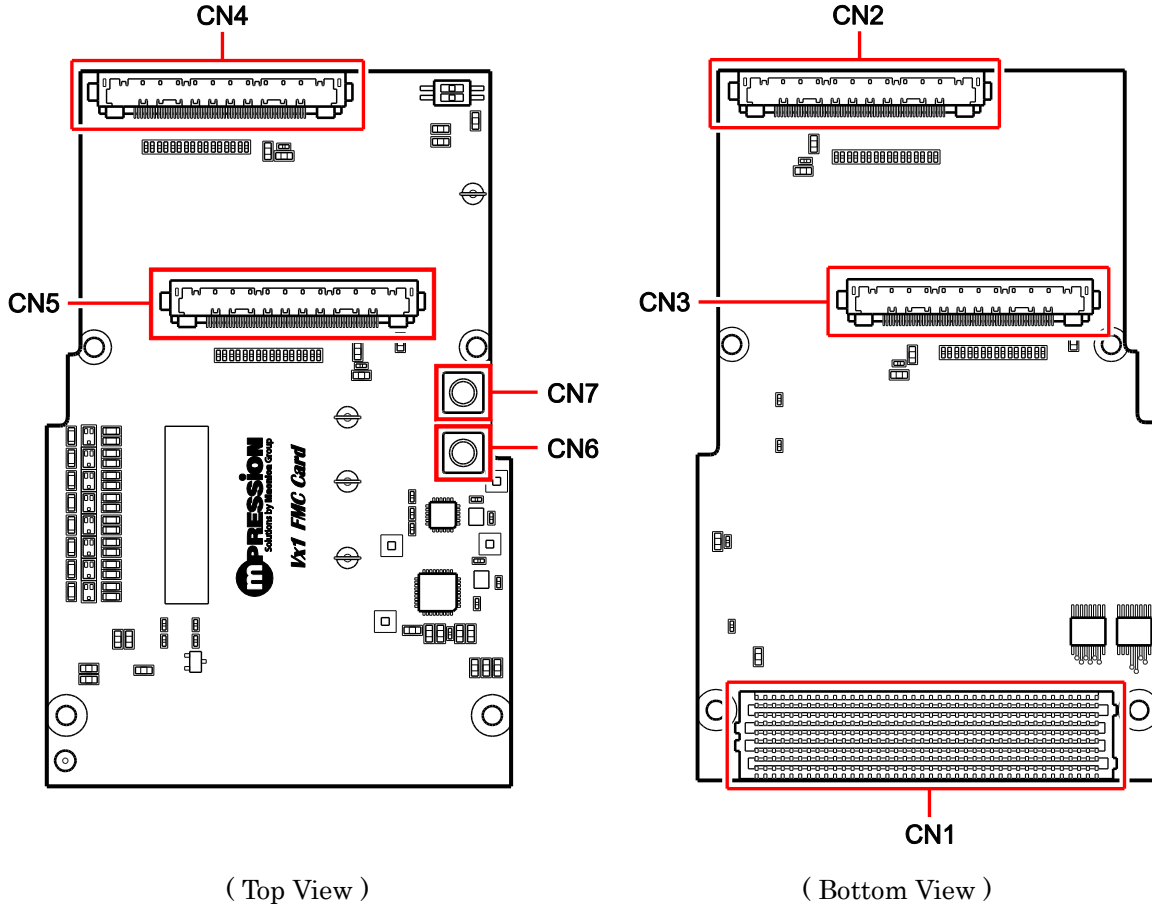

Figure 4-2 Connector Layout

Table 4-2 Connector Layout

Component Location	Connector Name	Silk Printing
CN1	FMC Connector	FMC
CN2	FX16 Connector	VbyOne_TX1
CN3	FX16 Connector	VbyOne_TX2
CN4	FX16 Connector	VbyOne_RX1
CN5	FX16 Connector	VbyOne_RX2
CN6	SMP Connector	GBTCLK_M2C_P1
CN7	SMP Connector	GBTCLK_M2C_N1

4.4.2 Component Layout

Figure 4-3 and Table 4-3 show the layout of main components on this Board.

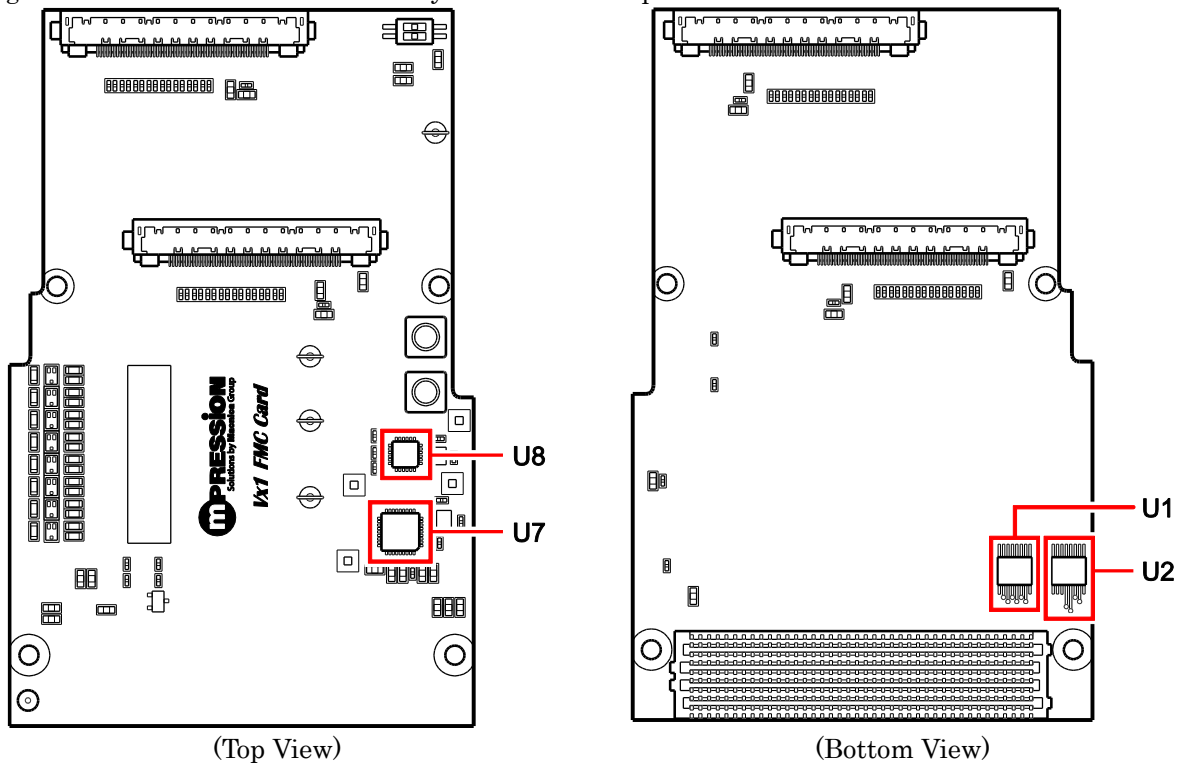

Figure 4-3 Component Layout

Table 4-3 Component Layout

Component Location	Component Name
U1	Level Shifter
U2	Level Shifter
U7	Jitter Attenuator
U8	Clock Generator

4.4.3 Switch and LED Layout and Specifications

Figure 4-4 and Table 4-4 show the layout of switches and LEDs on this Board.

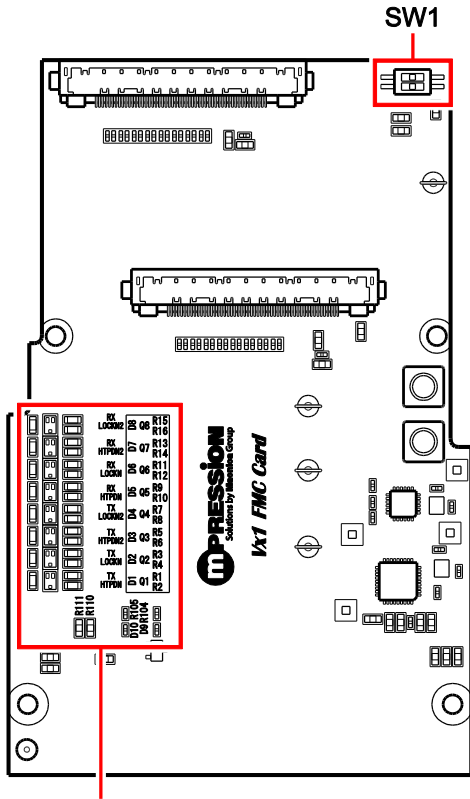

LED(D1-D10)

Figure 4-4 Switch and LED Layout

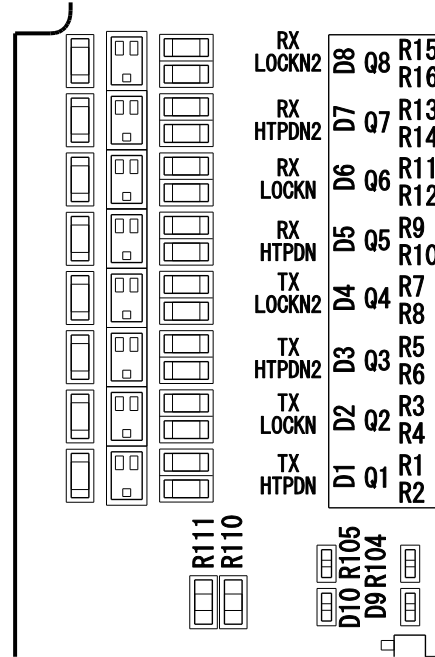

Figure 4-5 LED (D1 to D10) Enlarged View

Table 4-4 Switch and LED Layout

Component Location	Component Name	Switch Function
SW1	Si5335 setting switch	FS0: OFF (High) fixed FS1: ON (Low) fixed
D1	TX_HTPDN	Lit: Plug detected Unlit: Plug not detected
D3	TX_HTPDN2	
D5	RX_HTPDN	
D7	RX_HTPDN2	
D2	TX_LOCKN	Lit: Locked Unlit: Unlocked
D4	TX_LOCKN2	
D6	RX_LOCKN	
D8	RX_LOCKN2	
D9	+1.8 V power supply LED	-
D10	+3.3 V power supply LED	-

5. Hardware Specifications

This chapter describes the various types of hardware of the FPGA and peripherals.

5.1 Connector Pin Assignments

Table 5-1 to Table 5-7 show the layout of connectors and connector pins of this Board.

	K	J	H	G	F	E	D	C	B	A
1	NC	GND	NC	GND	NC	GND	NC	GND	NC	GND
2	GND	NC	GND	CLK_M2C_P1	NC	NC	GND	DP_C2M_P0	GND	DP_M2C_P1
3	GND	NC	GND	CLK_M2C_N1	GND	NC	GND	DP_C2M_N0	GND	DP_M2C_N1
4	DP_M2C_P10	GND	JAT_M2C_CLK_P	GND	NC	GND	GBTCLK_M2C_P0	GND	DP_M2C_P9	GND
5	DP_M2C_N10	GND	JAT_M2C_CLK_N	GND	NC	GND	GBTCLK_M2C_N0	GND	DP_M2C_N9	GND
6	GND	NC	GND	JAT_C2M_CLK_P	GND	NC	GND	DP_M2C_P0	GND	DP_M2C_P2
7	DP_M2C_P11	GND	NC	JAT_C2M_CLK_N	NC	NC	GND	DP_M2C_N0	GND	DP_M2C_N2
8	DP_M2C_N11	GND	NC	GND	NC	GND	NC	GND	DP_M2C_P8	GND
9	GND	NC	GND	NC	GND	NC	NC	GND	DP_M2C_N8	GND
10	DP_M2C_P12	GND	NC	JAT_C2M_RSTn	NC	NC	GND	NC	DP_M2C_P7	GND
11	DP_M2C_N12	GND	NC	GND	NC	GND	NC	GND	DP_M2C_N7	GND
12	GND	NC	GND	JAT_C2M_FROTB_L	NC	NC	NC	NC	DP_M2C_P4	GND
13	DP_M2C_P13	GND	NC	JAT_M2C_LoS	NC	NC	NC	NC	DP_M2C_N4	GND
14	DP_M2C_N13	GND	NC	GND	NC	NC	NC	NC	GND	GND
15	GND	NC	GND	JAT_C2M_DBL2_BY	GND	NC	NC	NC	DP_M2C_P6	GND
16	DP_M2C_P14	GND	NC	JAT_M2C_LOL	NC	NC	GND	GND	DP_M2C_N6	GND
17	DP_M2C_N14	GND	NC	GND	NC	NC	NC	NC	GND	GND
18	GND	NC	GND	JAT_C2M_DEC	GND	NC	NC	NC	DP_M2C_P5	GND
19	DP_M2C_P15	GND	NC	JAT_C2M_INC	NC	NC	NC	NC	DP_M2C_N5	GND
20	DP_M2C_N15	GND	NC	GND	NC	GND	NC	NC	GBTCLK_M2C_P1	GND
21	GND	NC	GND	JAT_C2M_BWSEL0	GND	NC	NC	GND	GBTCLK_M2C_N1	GND
22	DP_C2M_P10	GND	NC	JAT_C2M_BWSEL1	NC	NC	NC	NC	DP_C2M_P1	DP_C2M_P1
23	DP_C2M_N10	GND	NC	GND	NC	GND	NC	NC	DP_C2M_N1	DP_C2M_N1
24	GND	NC	GND	JAT_C2M_FRQSEL0	GND	NC	NC	GND	DP_C2M_P9	GND
25	DP_C2M_P11	GND	NC	JAT_C2M_FRQSEL1	NC	NC	NC	GND	DP_C2M_N9	GND
26	DP_C2M_N11	GND	NC	GND	NC	GND	NC	NC	GND	GND
27	GND	NC	GND	JAT_C2M_FRQSEL2	GND	NC	NC	NC	DP_C2M_P2	DP_C2M_P2
28	DP_C2M_P12	GND	NC	JAT_C2M_FRQSEL3	NC	NC	NC	NC	DP_C2M_N2	DP_C2M_N2
29	DP_C2M_N12	GND	NC	GND	NC	GND	NC	NC	DP_C2M_P8	DP_C2M_P8
30	GND	NC	GND	NC	NC	NC	NC	NC	DP_C2M_N8	DP_C2M_N8
31	DP_C2M_P13	GND	NC	NC	NC	NC	NC	NC	DP_C2M_P3	DP_C2M_P3
32	DP_C2M_N13	GND	NC	JATPDN2_C2M	NC	NC	NC	NC	DP_C2M_N3	DP_C2M_N3
33	GND	NC	GND	HTPDN2_C2M	GND	NC	FMC_3p3v	GND	DP_C2M_P7	GND
34	DP_C2M_P14	GND	HTPDN2_M2C	LOCKN2_C2M	NC	NC	NC	GND	DP_C2M_N7	GND
35	DP_C2M_N14	GND	LOCKN2_M2C	GND	NC	NC	NC	NC	DP_C2M_P4	DP_C2M_P4
36	GND	NC	GND	HTPDN_C2M	GND	GND	NC	FMC_12p0v	GND	DP_C2M_N4
37	DP_C2M_P15	GND	HTPDN_M2C	LOCKN_C2M	NC	NC	FMC_3p3v	GND	DP_C2M_P6	DP_C2M_P6
38	DP_C2M_N15	GND	LOCKN_M2C	GND	NC	NC	NC	FMC_12p0v	DP_C2M_N6	DP_C2M_N6
39	GND	NC	GND	FMC_12p0v	NC	FMC_12p0v	FMC_3p3v	GND	GND	GND
40	NC	GND	FMC_12p0v	GND	FMC_12p0v	GND	FMC_3p3v	GND	NC	DP_C2M_P5
										DP_C2M_N5
										GND

Table 5-1 CN1 (FMC)

Table 5-2 CN2 (VbyOne_TX1)

No.	Signal Name	No.	Signal Name	No.	Signal Name
1	NC	18	GND	35	TX_LOCKN
2	NC	19	GND	36	TX_HTPDN
3	GND	20	DP_C2M_P3	37	GND
4	DP_C2M_P7	21	DP_C2M_N3	38	GND
5	DP_C2M_N7	22	GND	39	GND
6	GND	23	GND	40	GND
7	GND	24	DP_C2M_P2	41	GND
8	DP_C2M_P6	25	DP_C2M_N2	42	FMC_3p3v
9	DP_C2M_N6	26	GND	43	FMC_3p3v
10	GND	27	GND	44	FMC_3p3v
11	GND	28	DP_C2M_P1	45	FMC_3p3v
12	DP_C2M_P5	29	DP_C2M_N1	46	FMC_3p3v
13	DP_C2M_N5	30	GND	47	FMC_3p3v
14	GND	31	GND	48	FMC_3p3v
15	GND	32	DP_C2M_P0	49	FMC_3p3v
16	DP_C2M_P4	33	DP_C2M_N0	50	FMC_3p3v
17	DP_C2M_N4	34	GND	51	FMC_3p3v

Table 5-3 CN3 (VbyOne_TX2)

No.	Signal Name	No.	Signal Name	No.	Signal Name
1	NC	18	GND	35	TX_LOCKN2
2	NC	19	GND	36	TX_HTPDN2
3	GND	20	DP_C2M_P11	37	GND
4	DP_C2M_P15	21	DP_C2M_N11	38	GND
5	DP_C2M_N15	22	GND	39	GND
6	GND	23	GND	40	GND
7	GND	24	DP_C2M_P10	41	GND
8	DP_C2M_P14	25	DP_C2M_N10	42	FMC_3p3v
9	DP_C2M_N14	26	GND	43	FMC_3p3v
10	GND	27	GND	44	FMC_3p3v
11	GND	28	DP_C2M_P9	45	FMC_3p3v
12	DP_C2M_P13	29	DP_C2M_N9	46	FMC_3p3v
13	DP_C2M_N13	30	GND	47	FMC_3p3v
14	GND	31	GND	48	FMC_3p3v
15	GND	32	DP_C2M_P8	49	FMC_3p3v
16	DP_C2M_P12	33	DP_C2M_N8	50	FMC_3p3v
17	DP_C2M_N12	34	GND	51	FMC_3p3v

Table 5-4 CN4 (VbyOne_RX1)

No.	Signal Name	No.	Signal Name	No.	Signal Name
1	FMC_3p3v	18	GND	35	DP_M2C_N4
2	FMC_3p3v	19	DP_M2C_N0	36	DP_M2C_P4
3	FMC_3p3v	20	DP_M2C_P0	37	GND
4	FMC_3p3v	21	GND	38	GND
5	FMC_3p3v	22	GND	39	DP_M2C_N5
6	FMC_3p3v	23	DP_M2C_N1	40	DP_M2C_P5
7	FMC_3p3v	24	DP_M2C_P1	41	GND
8	FMC_3p3v	25	GND	42	GND
9	FMC_3p3v	26	GND	43	DP_M2C_N6
10	FMC_3p3v	27	DP_M2C_N2	44	DP_M2C_P6
11	GND	28	DP_M2C_P2	45	GND
12	GND	29	GND	46	GND
13	GND	30	GND	47	DP_M2C_N7
14	GND	31	DP_M2C_N3	48	DP_M2C_P7
15	GND	32	DP_M2C_P3	49	GND
16	RX_HTPDN	33	GND	50	NC
17	RX_LOCKN	34	GND	51	NC

Table 5-5 CN5 (VbyOne_RX2)

No.	Signal Name	No.	Signal Name	No.	Signal Name
1	FMC_3p3v	18	GND	35	DP_M2C_N12
2	FMC_3p3v	19	DP_M2C_N8	36	DP_M2C_P12
3	FMC_3p3v	20	DP_M2C_P8	37	GND
4	FMC_3p3v	21	GND	38	GND
5	FMC_3p3v	22	GND	39	DP_M2C_N13
6	FMC_3p3v	23	DP_M2C_N9	40	DP_M2C_P13
7	FMC_3p3v	24	DP_M2C_P9	41	GND
8	FMC_3p3v	25	GND	42	GND
9	FMC_3p3v	26	GND	43	DP_M2C_N14
10	FMC_3p3v	27	DP_M2C_N10	44	DP_M2C_P14
11	GND	28	DP_M2C_P10	45	GND
12	GND	29	GND	46	GND
13	GND	30	GND	47	DP_M2C_N15
14	GND	31	DP_M2C_N11	48	DP_M2C_P15
15	GND	32	DP_M2C_P11	49	GND
16	RX_HTPDN2	33	GND	50	NC
17	RX_LOCKN2	34	GND	51	NC

Table 5-6 CN6 (GBTCLK_M2C_P1)

Pin	Signal Name	Pin	Signal Name
1	GBTCLK_M2C_P1	2	GND

Table 5-7 CN7 (GBTCLK_M2C_P1)

Pin	Signal Name	Pin	Signal Name
1	GBTCLK_M2C_N1	2	GND

5.2 Differential Clock Generator

This Board comes with a Silicon Labs Si5335 as a Differential Clock Generator. Refer to Figure 4-1 for information about connection between this LSI and the FMC connector.

Download the LSI's data sheet from the URL below:

<http://www.silabs.com/products/timing/clock-generator/si533x/pages/Si5335B.aspx>

* The destination of the above link is subject to change without notice.

5.3 Jitter Attenuator

This Board comes with a Silicon Labs Si5317 as a Jitter Attenuator. Refer to Figure 4-1 for pin information of this IC and the FMC connector.

Download this LSI's data sheet from the URL below.

<http://www.silabs.com/products/timing/clock-generator/si53xx/pages/Si5317B.aspx>

* The destination of the above link is subject to change without notice.

5.4 Power Tree

Figure 5-1 shows the power tree diagram of this Board.

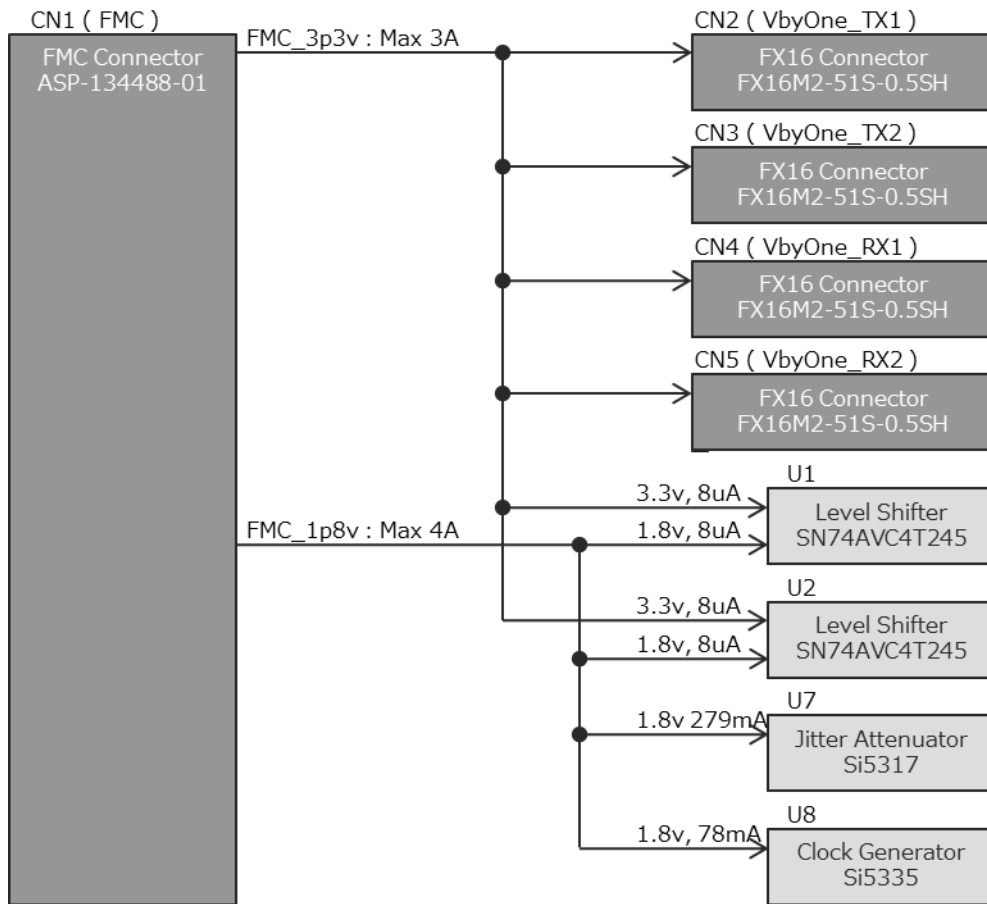

Figure 5-1 Power Tree