

VD6283 breakout board 6-channel ambient light sensor with advanced light flicker extraction

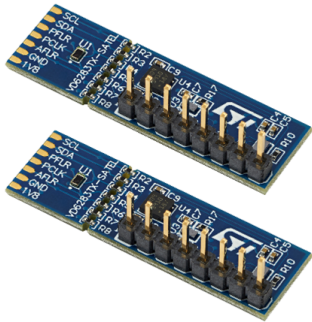

Features

- VD6283 6-channel Ambient Light Sensor (ALS) with advanced light flicker extraction
- Regulator: 5 V to 1.8 V range input voltage (output voltage: 1.8 V)
- VD6283 signal interface level shifter
- Divisible board enabling use as mini PCB breakout board, easy to integrate in customer device

Description

The VD6283TX-SATEL breakout boards can be used for easy integration into customer devices.

Thanks to the voltage regulator and level shifters, the VD6283 breakout boards can be used in any application with a 1.8 V to 5 V supply.

The PCB section supporting the VD6283 module is perforated so that developers can break off the mini PCB for use in a 1.8 V supply application using flying leads. This makes it easier to integrate the VD6283TX-SATEL breakout boards into development and evaluation devices due to their small size.

Root part number	Order code	Description
VD6283TX-SATEL	VD6283TX-SATEL/1	Two VD6283 breakout boards

1 VD6283 overview

The VD6283 (1.83 x 1.0 x 0.55 mm) is the smallest 6-channel, ambient light sensor (ALS) on the market. Light measurement is fast and accurate thanks to an individual ADC and readout circuitry for each color channel (Red, Green, Blue, IR, Clear and Visible). The VD6283 uses hybrid color filters with precise responses allowing accurate computation of the correlated color temperature (CCT) and Lux information. The VD6283 can be used for display brightness management or scene light correction.

With a patented architecture and a high-performance photodiode design, the VD6283T can extract light flickering frequencies to avoid “banding effects” on videos or check they are safe for human eye. Additionally, the VD6283 is the only sensor able to extract different light flicker waveforms from 100 Hz and 2 kHz, including LED square signals, that can run flicker operations simultaneously with ALS operations.

2 Breakable board

For 1.8 V supply applications, the breakout boards can be broken along the red dotted line as shown in the figure below, to use the “mini PCB”. This set up is easier to integrate into a customer device due to its small size.

Figure 1. Breakout board layout

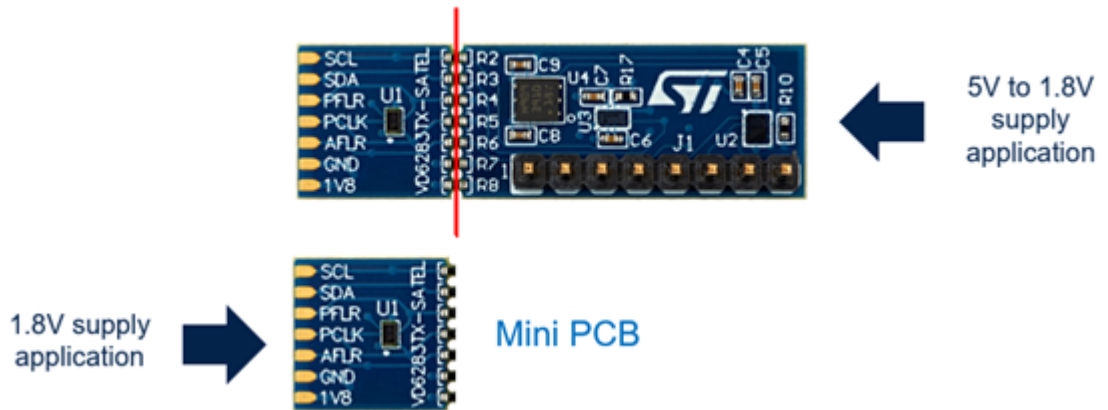

3 Schematic and list of materials

Figure 2. Breakoutboard schematic and list of materials

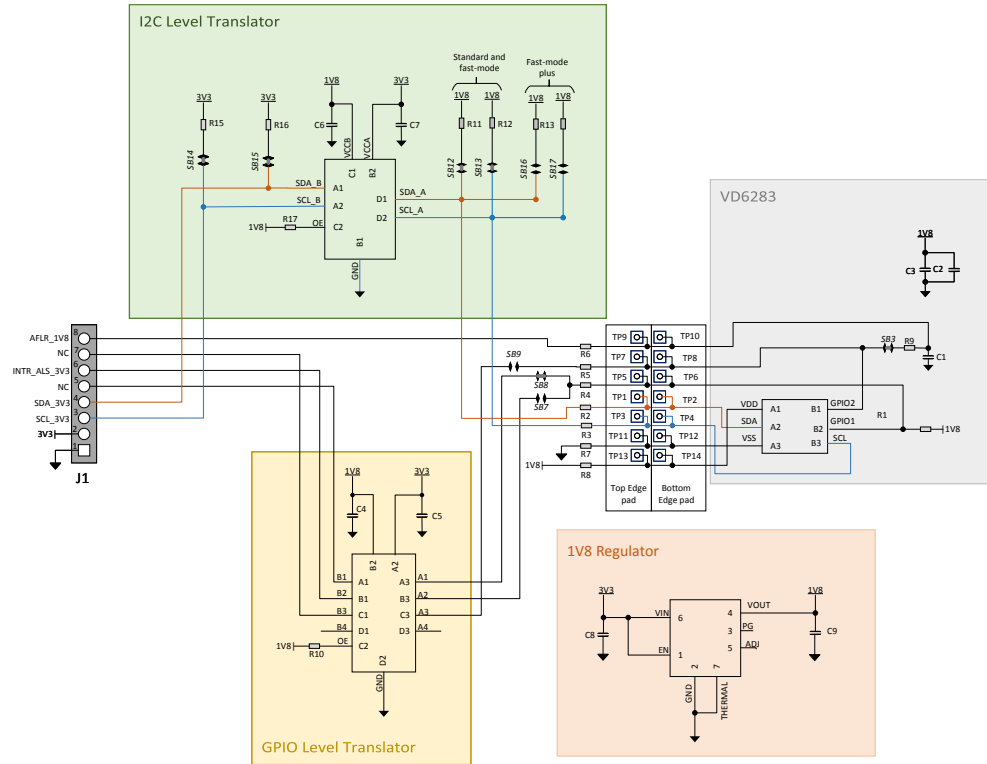

4 Package information

In order to meet environmental requirements, ST offers these devices in different grades of **ECOPACK** packages, depending on their level of environmental compliance. ECOPACK specifications, grade definitions and product status are available at: www.st.com. ECOPACK is an ST trademark.

Revision history

Table 1. Document revision history

Date	Version	Changes
11-May-2021	1	Initial release
01-Dec-2021	2	Device summary table: added root part number. Updated Figure 2 . Breakoutboard schematic and list of materials.