

VEK-F-30350-000  
SHT 1.1

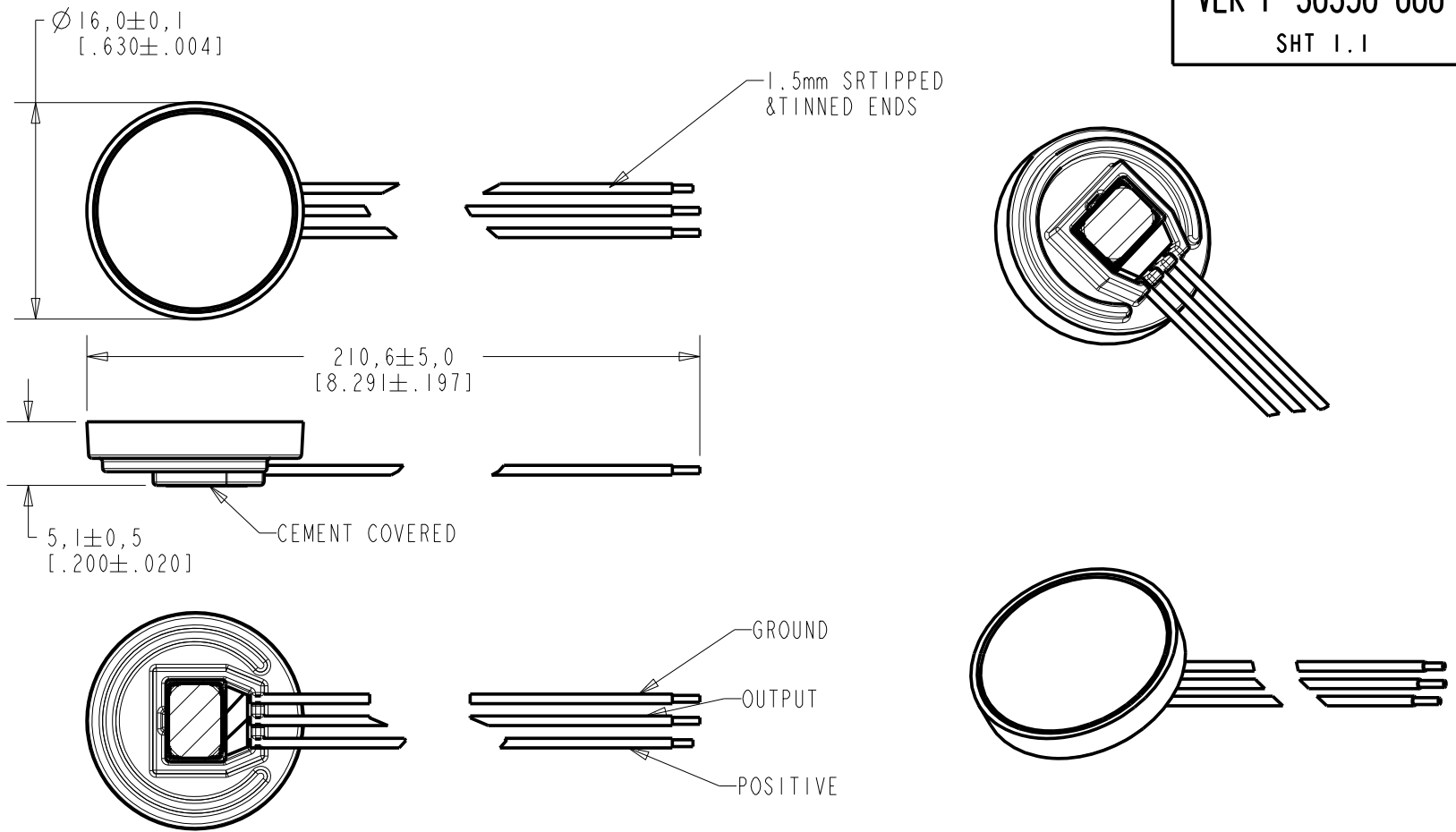

| WIRE COLOR |        | WEIGHT GRAMS |
|------------|--------|--------------|
| POSITIVE   | OUTPUT | t. b. d      |
| RED        | WHITE  |              |
|            |        | BLACK        |

DIMENSIONS IN MILLIMETERS [INCHES]

**KNOWLES ELECTRONICS**  
ITASCA, ILLINOIS U.S.A.

| Revision                            | C.O. #    | Implementation Date | RELEASE LEVEL | REVISION |
|-------------------------------------|-----------|---------------------|---------------|----------|
| C                                   | C10107779 | 8-20-08             | Active        | C        |
| B                                   | C10107752 | 8-12-08             |               |          |
| A                                   | C10107373 | 6-11-08             |               |          |
| SCALE: 2:1                          |           |                     | DR. BY        | DATE     |
| DO NOT SCALE DRAWING                |           |                     | TT            | 6-11-08  |
| TYPE: WATERPROOF MICROPHONE & CABLE |           |                     | CK. BY        | DATE     |
|                                     |           |                     | GJP           | 6-17-08  |
| OUTLINE DRAWING                     |           |                     | APP. BY       | DATE     |
|                                     |           |                     | GJP           | 6-17-08  |
| VEK-F-30350-000                     |           |                     | SHT 1.1       |          |

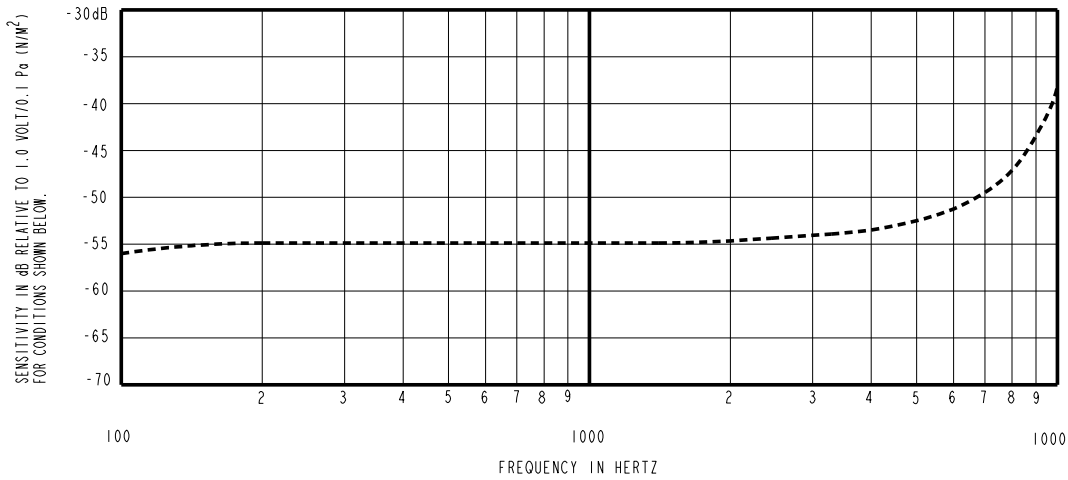

| FREQUENCY | SENSITIVITY |       |       | DEVICE CONFORMITY            |       |
|-----------|-------------|-------|-------|------------------------------|-------|
|           | MIN.        | NOM.  | MAX.  | RANGE OF DEVIATION FROM 1KHz |       |
| 100       | ---         | -56.0 | ---   | -4.0                         | +2.0  |
| 1000      | -58.0       | -55.0 | -52.0 | 0.0                          | 0.0   |
| 10000     | ---         | -38.0 | ---   | +12.0                        | +22.0 |

NOTES:

1. MICROPHONE TO BE FUNCTION WITH 10 VDC SUPPLY.
2. SENSITIVITY VALUES INDICATED ON THIS SPECIFICATION ARE VALID AT 50% HUMIDITY.
3. TEST CONDITIONS:  
SEAL PRODUCT TO 74 dBSPL SWEPT  
SOUND FIELD CREATED BY VOICE APERTURE.  
ARTIFICIAL VOICE:  
B & k 4227 MOUTH SIMULATOR.
4. FOR MICROPHONE CAPSULE SPEC. SEE DRAWING EK-23132-C36 SHEET 2.1.
5. SURVIVES SUBMERSION IN 1m OF WATER FOR 30 MINUTES;  
SENSITIVITY WITHIN 3dB OF INITIAL SENSITIVITY AFTER DRIED  
FOR 30 MINUTES AT ROOM TEMPERATURE.

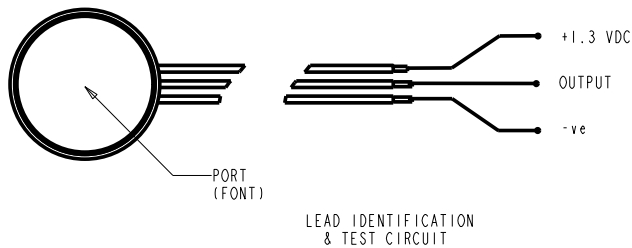

**KNOWLES ELECTRONICS**  
ITASCA, ILLINOIS U.S.A.

| Revision  | C.O. #    | Implementation Date | RELEASE LEVEL | REVISION                      |
|---|-----------|---------------------|---------------|-------------------------------|
| C   | C10107779 | 8-20-08             | <b>Active</b> | <b>C</b>                      |
| B   | C10107752 | 8-12-08             |               |                               |
| A   | C10107373 | 6-11-08             |               |                               |
| <small>WHEN TEST LIMITS ARE USED TO ESTABLISH INCOMING INSPECTION ACCEPTANCE/REJECTION CRITERIA, CORRELATION OF TEST EQUIPMENT WITH KNOWLES IS ALSO REQUIRED FOR ELIMINATION OF EQUIPMENT AND TEST METHOD VARIATION</small> |           |                     |               | DR. BY: TT<br>DATE: 6-11-08   |
| <b>TITLE WATERPROOF MICROPHONE &amp; CABLE VEK-F-30350-000</b>  |           |                     |               | CK. BY: GJP<br>DATE: 6-17-08  |
| PERFORMANCE SPECIFICATION   |           |                     |               | APP. BY: GJP<br>DATE: 6-17-08 |
| <b>SHT 2.1</b>  |           |                     |               |                               |