

Product Specifications

PART NO.:

VL33A1H63F-N6S
REV: 1.0

General Information

8GB 1Gx72 DDR4 SDRAM ULP ECC REGISTERED RDIMM 288-PIN

Description

The VL33A1H63F is a 1Gx72 DDR4 SDRAM high density RDIMM. This single rank memory module consists of nine CMOS 1Gx8 bits with 16 internal banks DDR4 Synchronous DRAMs in BGA packages, a 32-bit registered buffer/PLL clock in BGA package, and a 4K EEPROM with thermal sensor in an 8-pin MLF package. This module is a 288-pin registered dual in-line memory module and is intended for mounting into an edge connector socket. Decoupling capacitors are mounted on the printed circuit board for each DDR4 SDRAM.

Features

- 288-pin, registered dual in-line memory module (RDIMM)
- Supports ECC error detection and correction
- Fast data transfer rate: 2133MT/s
- VDD = VDDQ = 1.2V +/-0.060V
- VPP = 2.5V (2.375 min, 2.75 max)
- VDDSPD = 2.5V +/-0.25V
- 16 internal banks; 4 groups of 4 banks each
- Nominal and dynamic on-die termination (ODT)
- Low-power auto self refresh
- Programmable CAS# latency: 15 (DDR4-2133)
- Programmable burst length (8)
- Asynchronous reset
- On-die VREFDQ generation and calibration
- Fly-by topology
- On board terminated command, address, and control bus
- Serial presence detect (SPD) EEPROM with thermal sensor
- Thermal sensor range: -40°C to +125°C (Max +/-3% accuracy)
- Lead-free, RoHS compliant
- JEDEC pinout
- Gold edge contacts
- PCB: Height 17.78mm (0.700"), double sided component
- Operating temperature (T_{OPER})¹: - Commercial (0°C to +95°C)
- Industrial (-40°C to +95°C)

Notes: (1) Double refresh rate is required when 85°C < T_{OPER} <= 95°C.
T_{OPER} is DRAM case temperature.

Pin Description

Pin Name	Function
A0~A15	Row Address Inputs
A0~A9	Column Address Inputs
A10/AP	Address Input/ Autoprecharge
A12/BC#	Address Input/ Burst Chop
ACT#	Activate input
RAS#/A16	Row Address Strobes/ Address Input
CAS#/A15	Column Address Strobes/ Address Input
WE#/A14	Write Enable/Address Input
BA0~BA1	Bank Address Inputs
BG0~BG1	Bank group address inputs
DQ0~DQ63	Data Input/Output
DQS0~DQS8	Data Strobes
DQS0#~DQS8#	Data Strobes Complement
DM0#~DM8#	Data Mask Input
CB0~CB7	Data Check Bits I/O
PARITY	Parity Input
ALERT#	Alert output
CK0, CK0#	Clock Input
ODT0	On-die Termination Control
CKE0	Clock Enables
CS0#	Chip Selects
RESET#	Register and SDRAM Control
VDD	Voltage Supply
VPP	DRAM Activating Voltage Supply
VSS	Ground
SA0~SA2	SPD Address
SDA	SPD Data Input/Output
SCL	SPD Clock Input
EVENT#	Temperature Event Output
VREFCA	Reference Voltage for CA
VDDSPD	SPD Voltage Supply
VTT	Termination Voltage
NC	No Connect

Order Information:

VL33A1H63F - N6 S X - X
OPERATING TEMPERATURE

 None: Commercial
 S1: Industrial screening

DRAM DIE: (OPTION)
DRAM MANUFACTURER
 S - SAMSUNG

MODULE SPEED
 N6: DDR4-2133 @ CL15

VL: Lead-free/RoHS

Product Specifications

PART NO.:

VL33A1H63F-N6S
REV: 1.0

Pin Configuration

288-PIN DDR4 RDIMM FRONT SIDE								288-PIN DDR4 RDIMM BACK SIDE							
Pin	Name	Pin	Name	Pin	Name	Pin	Name	Pin	Name	Pin	Name	Pin	Name	Pin	Name
1	12V, NC*	37	VSS	73	VDD	109	VSS	145	12V, NC*	181	DQ29	217	VDD	253	DQ41
2	VSS	38	DQ24	74	CK0	110	DM5#/ DBI5#	146	VREFCA	182	VSS	218	CK1*	254	VSS
3	DQ4	39	VSS	75	CK0#	111	NC	147	VSS	183	DQ25	219	CK1#*	255	DQS5#
4	VSS	40	DM3#/ DBI3#	76	VDD	112	VSS	148	DQ5	184	VSS	220	VDD	256	DQS5
5	DQ0	41	NC	77	VTT	113	DQ46	149	VSS	185	DQS3#	221	VTT	257	VSS
6	VSS	42	VSS	78	EVENT#	114	VSS	150	DQ1	186	DQS3	222	PARITY	258	DQ47
7	DM0#/ DBI0#	43	DQ30	79	A0	115	DQ42	151	VSS	187	VSS	223	VDD	259	VSS
8	NC	44	VSS	80	VDD	116	VSS	152	DQS0#	188	DQ31	224	BA1	260	DQ43
9	VSS	45	DQ26	81	BA0	117	DQ52	153	DQS0	189	VSS	225	A10/AP	261	VSS
10	DQ6	46	VSS	82	RAS#/A16	118	VSS	154	VSS	190	DQ27	226	VDD	262	DQ53
11	VSS	47	CB4	83	VDD	119	DQ48	155	DQ7	191	VSS	227	NC	263	VSS
12	DQ2	48	VSS	84	CS0#	120	VSS	156	VSS	192	CB5	228	WE#/A14	264	DQ49
13	VSS	49	CB0	85	VDD	121	DM6#/ DBI6#	157	DQ3	193	VSS	229	VDD	265	VSS
14	DQ12	50	VSS	86	CAS#/A15	122	NC	158	VSS	194	CB1	230	SAVE/NC*	266	DQS6#
15	VSS	51	DM8#/ DBI8#	87	ODT0	123	VSS	159	DQ13	195	VSS	231	VDD	267	DQS6
16	DQ8	52	NC	88	VDD	124	DQ54	160	VSS	196	DQS8#	232	A13	268	VSS
17	VSS	53	VSS	89	CS1#*	125	VSS	161	DQ9	197	DQS8	233	VDD	269	DQ55
18	DM1#/ DBI1#	54	CB6	90	VDD	126	DQ50	162	VSS	198	VSS	234	A17*	270	VSS
19	NC	55	VSS	91	ODT1*	127	VSS	163	DQS1#	199	CB7	235	C2/NC*	271	DQ51
20	VSS	56	CB2	92	VDD	128	DQ60	164	DQS1	200	VSS	236	VDD	272	VSS
21	DQ14	57	VSS	93	C0/CS2#*	129	VSS	165	VSS	201	CB3	237	C1/CS3#*	273	DQ61
22	VSS	58	RESET#	94	VSS	130	DQ56	166	DQ15	202	VSS	238	SA2	274	VSS
23	DQ10	59	VDD	95	DQ36	131	VSS	167	VSS	203	CKE1*	239	VSS	275	DQ57
24	VSS	60	CKE0	96	VSS	132	DM7#/ DBI7#	168	DQ11	204	VDD	240	DQ37	276	VSS
25	DQ20	61	VDD	97	DQ32	133	NC	169	VSS	205	NC	241	VSS	277	DQS7#
26	VSS	62	ACT#	98	VSS	134	VSS	170	DQ21	206	VDD	242	DQ33	278	DQS7
27	DQ16	63	BG0	99	DM4#/ DBI4#	135	DQ62	171	VSS	207	BG1	243	VSS	279	VSS
28	VSS	64	VDD	100	NC	136	VSS	172	DQ17	208	ALERT#	244	DQS4#	280	DQ63
29	DM2#/ DBI2#	65	A12/BC#	101	VSS	137	DQ58	173	VSS	209	VDD	245	DQS4	281	VSS
30	NC	66	A9	102	DQ38	138	VSS	174	DQS2#	210	A11	246	VSS	282	DQ59
31	VSS	67	VDD	103	VSS	139	SA0	175	DQS2	211	A7	247	DQ39	283	VSS
32	DQ22	68	A8	104	DQ34	140	SA1	176	VSS	212	VDD	248	VSS	284	VDDSPD
33	VSS	69	A6	105	VSS	141	SCL	177	DQ23	213	A5	249	DQ35	285	SDA
34	DQ18	70	VDD	106	DQ44	142	VPP	178	VSS	214	A4	250	VSS	286	VPP
35	VSS	71	A3	107	VSS	143	VPP	179	DQ19	215	VDD	251	DQ45	287	VPP
36	DQ28	72	A1	108	DQ40	144	NC	180	VSS	216	A2	252	VSS	288	VPP

*: These pins are not used in this module.

Function Block Diagram

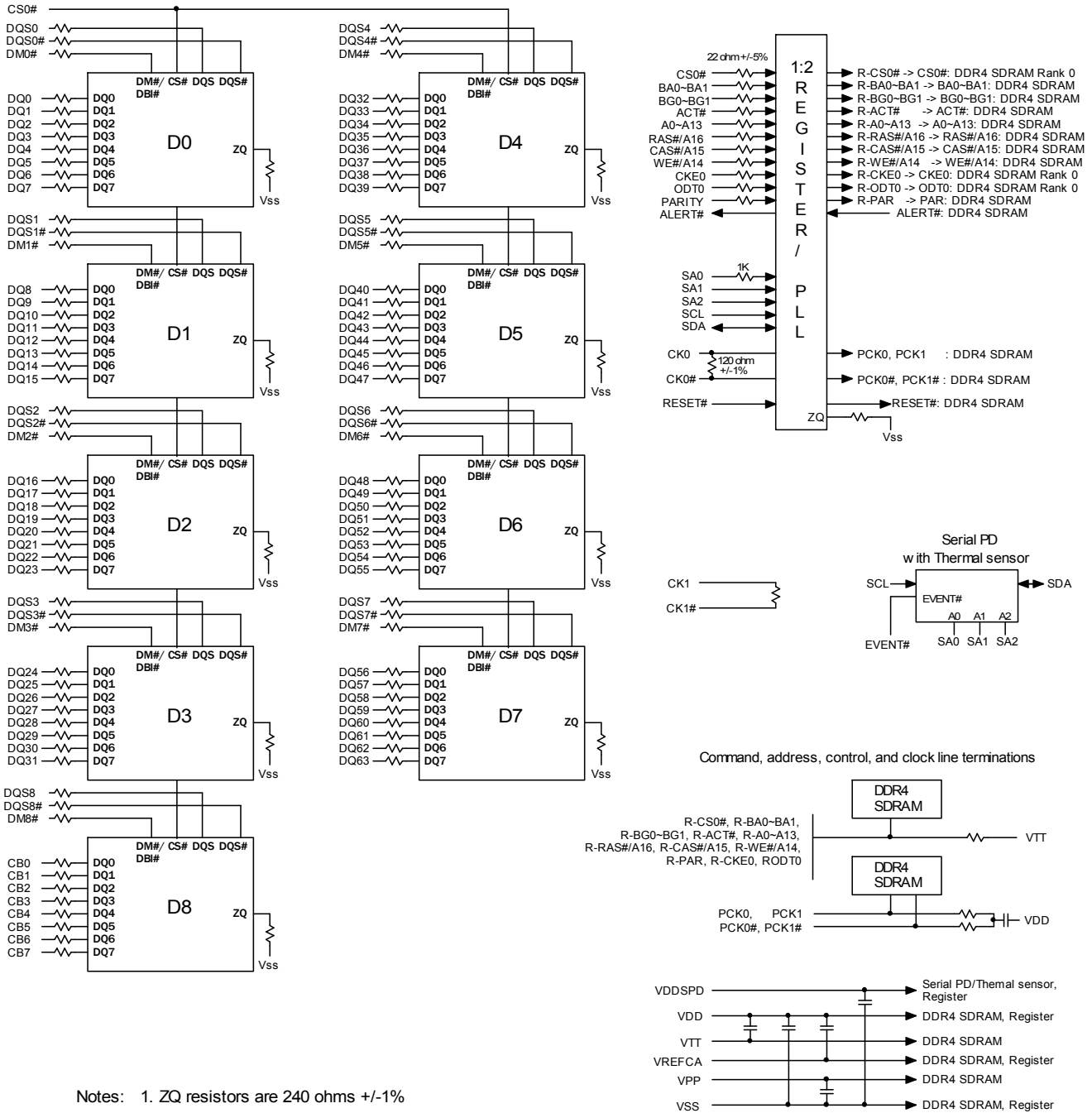

Product Specifications

PART NO.:

VL33A1H63F-N6S
REV: 1.0

Absolute Maximum Ratings

Symbol	Parameter	Min	Max	Unit	Notes
VDD	Voltage on VDD pin relative to VSS	-0.4	1.5	V	1
VDDQ	Voltage on VDDQ pin relative to VSS	-0.4	1.5	V	1
VPP	Voltage on VPP pin relative to VSS	-0.4	3.0	V	2
VIN, VOUT	Voltage on any pin relative to VSS	-0.4	1.5	V	
TSTG	Storage temperature	-55	100	°C	

- Notes:
- VDDQ balls on DRAM are tied to VDD.
 - VPP must be greater than or equal to VDD at all times.

DC Operating Conditions

Symbol	Parameter	Min	Typical	Max	Unit	Notes	
VDD	VDD Supply Voltage	1.14	1.2	1.26	V	1	
VDDQ	VDDQ Supply Voltage for Input/Output	1.14	1.2	1.26	V	1	
VPP	DRAM Activating Power Supply	2.375	2.5	2.750	V	2	
VREFCA (DC)	Input reference voltage CMD/ADD bus	0.49 x VDD	0.5 x VDD	0.51 x VDD	V	3	
VTT	Termination Reference Voltage (DC) - command/address bus	0.49 x VDD - 20mV	0.5 x VDDQ	0.51 x VDD + 20mV	V	4	
IVTT	Termination reference current from VTT	-750	-	750	mA		
I _i	Input leakage current; any input excluding ZQ; 0V < V _{IN} < 1.1V	Address inputs, RAS#, CAS#, WE#, CS#, CKE, ODT, BA, BG, PARITY	-5	-	5	µA	
		CK, CK#	-5	-	150	µA	
		DM#	-2	-	2	µA	
I _i	Input leakage current; ZQ	-27	-	27	µA	5	
I _{I/O}	DQ leakage; 0V < V _{in} < VDD	-36	-	36	µA		
IOZ _{pd}	Output leakage current; V _{OUT} =VDD; DQ is disabled	-	-	5	µA		
IOZ _{pu}	Output leakage current; V _{OUT} = V _{ss} ; DQ and ODT are disabled; ODT is disabled with ODT input HIGH	-	-	50	µA		
IVREFCA	VREFCA leakage; VREFCA = VDD/2 (after DRAM is initialized)	-18	-	18	µA		

- Notes:
- VDDQ tracks with VDD; VDDQ and VDD are tied together.
 - DC bandwidth is limited to 20 MHz.
 - VREFCA must not be greater than 0.6 x VDD. When VDD is less than 500mV, VREF may be less than or equal to 300mV.
 - VTT termination voltages in excess of specification limit will adversely affect command and address signals' voltage margins, and reduce timing margins.
 - Tied to ground. Not connected to edge connector.

Operating Temperature Condition

Symbol	Parameter	Rating	Units	Notes
TOPER	Operating temperature	Commercial	°C	1,2
		Industrial		

- Notes:
- Operating temperature is the case surface temperature on the center/top side of the DRAM. For the measurement conditions, please refer to JEDEC JESD51-2.
 - At -40°C to +85°C, operation temperature range, all DRAM specifications will be supported. The refresh rate is required to double when 85°C < TOPER <= 95°C.

Product Specifications

PART NO.:

VL33A1H63F-N6S
REV: 1.0

Speed Bins

Symbol	N6 DDR4-2133 (15-15-15) ¹	M4 DDR4-1866 (13-13-13) ¹	Unit
tCK(min)	0.938	1.071	ns
CAS Latency	15	13	nCK
tRCD(min)	14.06	13.92	ns
tRP(min)	14.06	13.92	ns
tRAS(min)	33	34	ns
tRC(min)	47.06	47.92	ns

Note: 1. Speed bin is in order of CL-tRCD-tRP

Command/Address Input Levels

Symbol	Parameter	N6/M4 DDR4-2133/1866		Unit	Note
		Min	Max		
VIH(DC)	DC Input High (Logic 1) Voltage	VREF + 0.075	VDD	V	1,2,3
VIL(DC)	DC Input Low (Logic 0) Voltage	VSS	VREF - 0.075	V	1,2
VIH(AC)	AC Input High (Logic 1) Voltage	VREF + 0.100	VDD	V	1,2
VIL(AC)	AC Input Low (Logic 0) Voltage	VSS	VREF - 0.100	V	1,2,3

- Notes:
- For input except RESET#. VREF = VREFCA(DC).
 - VREF = VREFCA(DC).
 - Input signal must meet VIL/VIH(AC) to meet tIS/tIH timings.

AC & DC Output Levels

Symbol	Parameter	Value	Unit	Note
VOH(DC)	DC output high measurement level (for IV curve linearity)	1.1 x VDDQ	V	
VOM(DC)	DC output mid measurement level (for IV curve linearity)	0.8 x VDDQ	V	
VOL(DC)	DC output low measurement level (for IV curve linearity)	0.5 x VDDQ	V	
VOH(AC)	AC output high measurement level (for output SR)	(0.7 + 0.15) x VDDQ	V	1
VOL(AC)	AC output low measurement level (for output SR)	(0.7 - 0.15) x VDDQ	V	1
VOHdiff(AC)	AC differential output high measurement level (for output SR)	+0.3 x VDDQ	V	2
VOLdiff(AC)	AC differential output low measurement level (for output SR)	-0.3 x VDDQ	V	2

- Notes:
- The swing of $\pm 0.15 \times VDDQ$ is based on approximately 50% of the static single-ended output peak-to-peak swing with a driver impedance of $RZQ/7\Omega$ and an effective test load of 50Ω to $VTT = VDDQ$.
 - The swing of $\pm 0.3 \times VDDQ$ is based on approximately 50% of the static single-ended output peak-to-peak swing with a driver impedance of $RZQ/7\Omega$ and an effective test load of 50Ω to $VTT = VDDQ$.

Input/Output Capacitance

TA=25°C, f=100MHz

Parameter	Symbol	N6 (DDR4-2133)		Unit
		Min	Max	
Input capacitance (BA0~BA1, BG0~BG1, A0~A13, RAS#/A16, CAS#/A15, WE#/A14, ACT#)	CIN1	4.8	5.1	pF
Input capacitance (CKE0, ODT0, CS0#)	CIN2	4.8	5.1	pF
Input capacitance (CK0, CK0#)	CIN3	4.8	5.1	pF
Input/Output capacitance (DQ, DQS, DQS#, DM#, CB)	CIO	4.6	5.4	pF

Product Specifications

PART NO.:

VL33A1H63F-N6S
REV: 1.0

IDD & IPP Specifications

Parameter	Symbol	N6 (DDR4-2133)	Unit
One bank ACTIVATE-PRECHARGE current	IDD0	293	mA
One bank ACTIVATE-PRECHARGE, word line boost, IPP current	IPP0	36	mA
One bank ACTIVATE-READ-PRECHARGE current	IDD1	338	mA
Precharge standby current	IDD2N	203	mA
Precharge standby ODT current	IDD2NT	203	mA
Precharge power-down current	IDD2P	149	mA
Precharge quiet standby current	IDD2Q	194	mA
Active standby current	IDD3N	293	mA
Active standby IPP current	IPP3N	27	mA
Active power-down current	IDD3P	221	mA
Burst read current	IDD4R	734	mA
Burst write current	IDD4W	716	mA
Burst refresh current (1 x REF)	IDD5B	1715	mA
Burst refresh IPP current (1 x REF)	IPP5B	162	mA
Self refresh current: Normal temperature range (0°C to +85°C)	IDD6N	239	mA
Self refresh current: Extended temperature range (0°C to +95°C)	IDD6E	356	mA
Self refresh current: Reduced temperature range (0°C to +45°C)	IDD6R	185	mA
Auto self refresh current	IDD6A	239	mA
Bank interleave read current	IDD7	1238	mA
Bank interleave read IPP current	IPP7	90	mA
Maximum power-down current	IDD8	131	mA
Note: IDD specification is based on Samsung 8Gb C-die components.			

Product Specifications

PART NO.:
VL33A1H63F-N6S
REV: 1.0

AC TIMING PARAMETERS & SPECIFICATIONS

Speed		N6 DDR4-2133		M4 DDR4-1866		Units
		MIN	MAX	MIN	MAX	
Parameter	Symbol					
Clock Timing						
Minimum Clock Cycle Time (DLL off mode)	tCK (DLL_OFF)	8	20	8	20	ns
Average Clock Period	tCK(avg)	0.938	<1.071	1.071	<1.25	ns
Average high pulse width	tCH(avg)	0.48	0.52	0.48	0.52	tCK(avg)
Average low pulse width	tCL(avg)	0.48	0.52	0.48	0.52	tCK(avg)
Absolute Clock Period	tCK(abs)	tCK(avg)min + tJIT(per)min_tot tCK(avg)max + tJIT(per)max_tot				tCK(avg)
Absolute clock HIGH pulse width	tCH(abs)	0.45	-	0.45	-	tCK(avg)
Absolute clock LOW pulse width	tCL(abs)	0.45	-	0.45	-	tCK(avg)
Clock Period Jitter- total	JIT(per)_tot	-47	47	-54	54	ps
Clock Period Jitter- deterministic	JIT(per)_dj	-23	23	-27	27	ps
Clock Period Jitter during DLL locking period	tJIT(per, lck)	-38	38	-43	43	ps
Cycle to Cycle Period Jitter	tJIT(cc)_tot	-	94	-	107	ps
Cycle to Cycle Period Jitter during DLL locking period	tJIT(cc, lck)	-	75	-	86	ps
Cumulative error across 2 cycles	tERR(2per)	-69	69	-79	79	ps
Cumulative error across 3 cycles	tERR(3per)	-82	82	-94	94	ps
Cumulative error across 4 cycles	tERR(4per)	-91	91	-104	104	ps
Cumulative error across 5 cycles	tERR(5per)	-98	98	-112	112	ps
Cumulative error across 6 cycles	tERR(6per)	-104	104	-119	119	ps
Cumulative error across 7 cycles	tERR(7per)	-109	109	-124	124	ps
Cumulative error across 8 cycles	tERR(8per)	-113	113	-129	129	ps
Cumulative error across 9 cycles	tERR(9per)	-117	117	-134	134	ps
Cumulative error across 10 cycles	tERR(10per)	-120	120	-137	137	ps
Cumulative error across 11 cycles	tERR(11per)	-123	123	-141	141	ps
Cumulative error across 12 cycles	tERR(12per)	-126	126	-144	144	ps
Cumulative error across 13 cycles	tERR(13per)	-129	129	-147	147	ps
Cumulative error across 14 cycles	tERR(14per)	-131	131	-150	150	ps
Cumulative error across 15 cycles	tERR(15per)	-133	133	-152	152	ps
Cumulative error across 16 cycles	tERR(16per)	-135	135	-155	155	ps
Cumulative error across 17 cycles	tERR(17per)	-137	137	-157	157	ps
Cumulative error across 18 cycles	tERR(18per)	-139	139	-159	159	ps
Cumulative error across n = 13, 14 . . . 49, 50 cycles	tERR(nper)	tERR(nper)min = ((1 + 0.68ln(n)) * tJIT(per)_total min) tERR(nper)max = ((1 + 0.68ln(n)) * tJIT(per)_total max)				ps
Command and Address setup time to CK, CK# referenced to Vih(ac) / Vil(ac) levels	tIS(base)	80	-	100	-	ps
Command and Address setup time to CK, CK# referenced to Vref levels	tIS(Vref)	180	-	200	-	ps
Command and Address hold time to CK, CK# referenced to Vih(dc) / Vil(dc) levels	tIH(base)	105	-	125	-	ps
Command and Address hold time to CK, CK# referenced to Vref levels	tIH(Vref)	180	-	200	-	ps
Control and Address Input pulse width for each input	tIPW	460	-	525	-	ps
Command and Address Timing						
CAS# to CAS# command delay for same bank group	tCCD_L	max(5 nCK, 5.625 ns)	-	max(5 nCK, 5.355 ns)	-	nCK
CAS# to CAS# command delay for different bank group	tCCD_S	4	-	4	-	nCK

Product Specifications

PART NO.:
VL33A1H63F-N6S
REV: 1.0

AC TIMING PARAMETERS & SPECIFICATIONS

Speed		N6 DDR4-2133		M4 DDR4-1866		Units
Parameter	Symbol	MIN	MAX	MIN	MAX	
ACTIVATE to ACTIVATE Command delay to different bank group for 2KB page size	tRRD_S(2K)	Max(4nCK, 5.3ns)	-	Max(4nCK, 5.3ns)	-	nCK
ACTIVATE to ACTIVATE Command delay to different bank group for 2KB page size	tRRD_S(1K)	Max(4nCK, 3.7ns)	-	Max(4nCK, 4.2ns)	-	nCK
ACTIVATE to ACTIVATE Command delay to different bank group for 1/2KB page size	tRRD_S (1/2K)	Max(4nCK, 3.7ns)	-	Max(4nCK, 4.2ns)	-	nCK
ACTIVATE to ACTIVATE Command delay to same bank group for 2KB page size	tRRD_L(2K)	Max(4nCK, 6.4ns)	-	Max(4nCK, 6.4ns)	-	nCK
ACTIVATE to ACTIVATE Command delay to same bank group for 1KB page size	tRRD_L(1K)	Max(4nCK, 5.3ns)	-	Max(4nCK, 5.3ns)	-	nCK
ACTIVATE to ACTIVATE Command delay to same bank group for 1/2KB page size	tRRD_L (1/2K)	Max(4nCK, 5.3ns)	-	Max(4nCK, 5.3ns)	-	nCK
Four activate window for 2KB page size	tFAW_2K	Max(28nCK,30ns)	-	Max(28nCK,30ns)	-	ns
Four activate window for 1KB page size	tFAW_1K	Max(20nCK,21ns)	-	Max(20nCK,23ns)	-	ns
Four activate window for 1/2KB page size	tFAW_1/2K	Max(16nCK,15ns)	-	Max(16nCK,17ns)	-	ns
Delay from start of internal write trans- action to internal read command for different bank group	tWTR_S	max(2nCK, 2.5ns)	-	max(2nCK, 2.5ns)	-	ns
Delay from start of internal write trans- action to internal read command for same bank group	tWTR_L	max(4nCK, 7.5ns)	-	max(4nCK, 7.5ns)	-	ns
Internal READ Command to PRE- CHARGE Command delay	tRTP	max(4nCK, 7.5ns)	-	max(4nCK, 7.5ns)	-	ns
WRITE recovery time	tWR	15	-	15	-	ns
Write recovery time when CRC and DM are enabled	tWR_CRC_DM	tWR+max (5nCK, 3.75ns)	-	tWR+max (5nCK, 3.75ns)	-	ns
delay from start of internal write trans- action to internal read command for different bank group with both CRC and DM enabled	tWTR_S_CRC_DM	tWTR_S + max(5nCK, 3.75ns)	-	tWTR_S + max(5nCK, 3.75ns)	-	ns
delay from start of internal write trans- action to internal read command for same bank group with both CRC and DM enabled	tWTR_L_CRC_DM	tWTR_L + max(5nCK, 3.75ns)	-	tWTR_L + max(5nCK, 3.75ns)	-	ns
DLL locking time	tDLLK	768	-	597	-	nCK
Mode Register Set command cycle time	tMRD	8	-	8	-	nCK
Mode Register Set command update delay	tMOD	max(24nCK,15ns)	-	max(24nCK,15ns)	-	nCK
Multi-Purpose Register Recovery Time	tMPRR	1	-	1	-	nCK
Multi Purpose Register Write Recovery Time	tWR_MPR	tMOD (min) + AL + PL	-	tMOD (min) + AL + PL	-	nCK
Auto precharge write recovery + precharge time	tDAL(min)	Programmed WR + roundup (tRP / tCK(avg))				nCK
DQ0 or DQL0 driven to 0 set-up time to first DQS rising edge	tPDA_S	0.5	-	0.5	-	UI
DQ0 or DQL0 driven to 0 hold time from last DQS fall-ing edge	tPDA_H	0.5	-	0.5	-	UI
CS# to Command Address Latency						
CS# to Command Address Latency	tCAL	max(3 nCK, 3.748 ns)	-	max(3 nCK, 3.748 ns)	-	nCK
Mode Register Set cyce time in CAL mode	tMRD_tCAL	tMOD+ tCAL	-	tMOD+ tCAL	-	nCK
Mode Register Set update delay in CAL mode	tMOD_tCAL	tMOD+ tCAL	-	tMOD+ tCAL	-	nCK
DRAM Data Timing						
DQS,DQS# to DQ skew, per group, per access	tDQSQ	-	0.16	-	0.16	tCK(avg) /2
DQ output hold time from DQS,DQS#	tQH	0.76	-	0.76	-	tCK(avg) /2



Product Specifications

PART NO.:

VL33A1H63F-N6S

REV: 1.0

AC TIMING PARAMETERS & SPECIFICATIONS

Speed		N6 DDR4-2133		M4 DDR4-1866		Units
Parameter	Symbol	MIN	MAX	MIN	MAX	
Data Valid Window per device: tQH- tDQSQ for a device	tDVWd	0.64	-	0.63	-	UI
Data Valid Window per device, per pin: tQH- tDQSQ each device's output	tDVWp	0.69	-	0.66	-	UI
DQ low impedance time from CK, CK#	tLZ(DQ)	-360	180	-390	195	ps
DQ high impedance time from CK, CK#	tLH(DQ)	-	180	-	195	ps
Data Strobe Timing						
DQS, DQS# differential READ Pre-amble (1tCK toggle mode)	tRPRE	0.9	Note 1	0.9	Note 1	tCK
DQS, DQS# differential READ Pre-amble (2tCK toggle mode)	tRPRE	NA	NA	NA	NA	tCK
DQS, DQS# differential READ Postamble	tRPST	0.33	Note 2	0.33	Note 2	tCK
DQS, DQS# differential output high time	tQSH	0.4	-	0.4	-	tCK
DQS, DQS# differential output low time	tQSL	0.4	-	0.4	-	tCK
DQS, DQS# differential WRITE Preamble (1tCK mode)	tWPRE	0.9	-	0.9	-	tCK
DQS, DQS# differential WRITE Preamble (2tCK mode)	tWPRE	NA	-	NA	-	tCK
DQS, DQS# differential WRITE Postamble	tWPST	0.33	-	0.33	-	tCK
DQS and DQS# low-impedance time (Referenced from RL-1)	tLZ(DQS)	-360	180	-390	195	ps
DQS and DQS# high-impedance time (Referenced from RL+BL/2)	tHZ(DQS)	-	180	-	195	ps
DQS, DQS# differential input low pulse width	tDQSL	0.46	0.54	0.46	0.54	tCK
DQS, DQS# differential input high pulse width	tDQSH	0.46	0.54	0.46	0.54	tCK
DQS, DQS# rising edge to CK, CK# rising edge (1 clock preamble)	tDQSS	-0.27	0.27	-0.27	0.27	tCK
DQS, DQS# falling edge setup time to CK, CK# rising edge	tDSS	0.18	-	0.18	-	tCK
DQS, DQS# falling edge hold time from CK, CK# rising edge	tDSH	0.18	-	0.18	-	tCK
DQS, DQS# rising edge output timing locatino from rising CK, CK# with DLL On mode	tDQSCK (DLL On)	-180	180	-195	195	ps
DQS, DQS# rising edge output variance window per DRAM	tDQSKI (DLL On)	-	310	-	330	ps
MPSM Timing						
Command path disable delay upon MPSM entry	tMPED	tMOD(min) + tCP-DED (min)	-	tMOD(min) + tCP-DED (min)	-	
Valid clock requirement after MPSM entry	tCKMPE	tMOD(min) + tCP-DED (min)	-	tMOD(min) + tCP-DED (min)	-	
Valid clock requirement before MPSM exit	tCKMPX	tCKSRX (min)	-	tCKSRX (min)	-	
Exit MPSM to commands not requir- ing a locked DLL	tXMP	tXS(min)	-	tXS(min)	-	
Exit MPSM to commands requiring a locked DLL	tXMPDLL	tXMP(min) + tXSDLL(min)	-	tXMP(min) + tXSDLL(min)	-	
CS setup time to CKE	tMPX_S	tIS(min) + tIHL(min)	-	tIS(min) + tIHL(min)	-	
CS# High hold time to CKE rising edge	tMPX_HH	tXP(min)	-	tXP(min)	-	
CS# Low hold time to CKE rising edge	tMPX_LH	12	tXMP-10ns	12	tXMP-10ns	ns
Calibration Timing						
Power-up and RESET calibration time	tZQinit	1024	-	1024	-	nCK
Normal operation Full calibration time	tZQoper	512	-	512	-	nCK
Normal operation Short calibration time	tZQCS	128	-	128	-	nCK

Product Specifications

PART NO.:
VL33A1H63F-N6S
REV: 1.0

AC TIMING PARAMETERS & SPECIFICATIONS

Speed		N6 DDR4-2133		M4 DDR4-1866		Units
Parameter	Symbol	MIN	MAX	MIN	MAX	
Reset/Self Refresh Timing						
Exit Reset from CKE HIGH to a valid command	tXPR	max (5nCK,tRFC (min)+10ns)	-	max (5nCK,tRFC (min)+10ns)	-	nCK
Exit Self Refresh to commands not requiring a locked DLL	tXS	tRFC(min)+ 10ns	-	tRFC(min)+ 10ns	-	nCK
SRX to commands not requiring a locked DLL in Self Refresh ABORT	tXS_ABORT (min)	tRFC4(min)+ 10ns	-	tRFC4(min)+ 10ns	-	nCK
Exit Self Refresh to ZQCL,ZQCS and MRS (CL,CWL,WR,RTP and Gear Down)	tXS_FAST (min)	tRFC4(min)+ 10ns	-	tRFC4(min)+ 10ns	-	nCK
Exit Self Refresh to commands requiring a locked DLL	tXSDLL	tDLLK(min)	-	tDLLK(min)	-	nCK
Minimum CKE low width for Self refresh entry to exit timing	tCKESR	tCKE(min)+ 1nCK	-	tCKE(min)+ 1nCK	-	nCK
Minimum CKE low width for Self refresh entry to exit timing with CA Parity enabled	tCKESR_PAR	tCKE(min)+ 1nCK+PL	-	tCKE(min)+ 1nCK+PL	-	nCK
Valid Clock Requirement after Self Refresh Entry (SRE) or Power-Down Entry (PDE)	tCKSRE	Max (5nCK,10ns)	-	Max (5nCK,10ns)	-	nCK
Valid Clock Requirement after Self Refresh Entry (SRE) or Power-Down when CA Parity is enabled	tCKSRE_PAR	max (5nCK,10ns) +PL	-	max (5nCK,10ns) +PL	-	nCK
Valid Clock Requirement before Self Refresh Exit (SRX) or Power-Down Exit (PDX) or Reset Exit	tCKSRX	max(5nCK, 10 ns)	-	max(5nCK, 10 ns)	-	nCK
Power Down Timing						
Exit Power Down with DLL on to any valid command;Exit Precharge Power Down with DLL frozen to commands not requiring a locked DLL	tXP	max (4nCK,6ns)	-	max (4nCK,6ns)	-	nCK
CKE minimum pulse width	tCKE	max (3nCK, 5ns)	-	max (3nCK, 5ns)	-	nCK
Command pass disable delay	tCPDED	4	-	4	-	nCK
Power Down Entry to Exit Timing	tPD	tCKE(min)	9*tREFI	tCKE(min)	9*tREFI	
Timing of ACT command to Power Down entry	tACTPDEN	2	-	1	-	nCK
Timing of PRE or PREA command to Power Down entry	tPRPDEN	2	-	1	-	nCK
Timing of RD/RDA command to Power Down entry	tRDPDEN	RL+4+1	-	RL+4+1	-	nCK
Timing of WR command to Power Down entry (BL8OTF, BL8MRS, BC4OTF)	tWRPDEN	WL+4+(tWR/ tCK(avg))	-	WL+4+(tWR/ tCK(avg))	-	nCK
Timing of WRA command to Power Down entry (BL8OTF, BL8MRS, BC4OTF)	tWRAPDEN	WL+4+WR+1	-	WL+4+WR+1	-	nCK
Timing of WR command to Power Down entry (BC4MRS)	tWRPBC4DEN	WL+2+(tWR/ tCK(avg))	-	WL+2+(tWR/ tCK(avg))	-	nCK
Timing of WRA command to Power Down entry (BC4MRS)	tWRAPBC4DEN	WL+2+WR+1	-	WL+2+WR+1	-	nCK
Timing of REF command to Power Down entry	tREFPDEN	2	-	1	-	nCK
Timing of MRS command to Power Down entry	tMRSPDEN	tMOD(min)	-	tMOD(min)	-	nCK
PDA Timing						
Mode Register Set command cycle time in PDA mode	tMRD_PDA	max(16nCK,10ns)	-	max(16nCK,10ns)	-	nCK
Mode Register Set command update delay in PDA mode	tMOD_PDA	tMOD		tMOD		nCK
ODT Timing						
Asynchronous RTT turn-on delay (Power-Down with DLL frozen)	tAONAS	1.0	9.0	1.0	9.0	ns
Asynchronous RTT turn-off delay (Power-Down with DLL frozen)	tAOFAS	1.0	9.0	1.0	9.0	ns
RTT dynamic change skew	tADC	0.3	0.7	0.3	0.7	tCK(avg)



Product Specifications

PART NO.:

VL33A1H63F-N6S

REV: 1.0

AC TIMING PARAMETERS & SPECIFICATIONS

Speed		N6 DDR4-2133		M4 DDR4-1866		Units
Parameter	Symbol	MIN	MAX	MIN	MAX	
Write Leveling Timing						
First DQS/DQS# rising edge after write leveling mode is programmed	tWLMRD	40	-	40	-	nCK
DQS/DQS# delay after write leveling mode is programmed	tWLDQSEN	25	-	25	-	nCK
Write leveling setup time from rising CK, CK# crossing to rising DQS/ DQS# crossing	tWLS	0.13	-	0.13	-	tCK(avg)
Write leveling hold time from rising DQS/DQS# crossing to rising CK, CK# crossing	tWLH	0.13	-	0.13	-	tCK(avg)
Write leveling output delay	tWLO	0	9.5	0	9.5	ns
Write leveling output error	tWLOE	0	2	0	2	ns
CA Parity Timing						
Commands not guaranteed to be executed during this time	tPAR_UNKN OWN	-	PL	-	PL	nCK
Delay from errant command to ALERT# assertion	tPAR_ALER T_ON	-	PL+6ns	-	PL+6ns	nCK
Pulse width of ALERT# signal when asserted	tPAR_ALER T_PW	64	128	56	112	nCK
Time from when Alert is asserted till controller must start providing DES commands in Persistent CA parity mode	tPAR_ALER T_RSP	-	57	-	50	nCK
Parity Latency	PL	5		4		nCK
CRC Error Reporting						
CRC error to ALERT# latency	tCRC_ALERT	3	13	3	13	ns
CRC ALERT# pulse width	CRC_ALER T_PW	6	10	6	10	nCK
Geardown timing						
Exit RESET from CKE HIGH to a valid MRS geardown (T2/Reset)	tXPR_GEAR	-	-	-	-	
CKE High Assert to Gear Down Enable time(T2/CKE)	tXS_GEAR	-	-	-	-	
MRS command to Sync pulse time(T3)	tSYNC_GEA R	-	-	-	-	
Sync pulse to First valid command(T4)	tCMD_GEAR	-	-	-	-	
Geardown setup time	tGEAR_setup	-	-	-	-	nCK
Geardown hold time	tGEAR_hold	-	-	-	-	nCK
tREFI						
tRFC1 (min)	2Gb	160	-	160	-	ns
	4Gb	260	-	260	-	ns
	8Gb	350	-	350	-	ns
	16Gb	550	-	550	-	ns
tRFC2 (min)	2Gb	110	-	110	-	ns
	4Gb	160	-	160	-	ns
	8Gb	260	-	260	-	ns
	16Gb	350	-	350	-	ns
tRFC4 (min)	2Gb	90	-	90	-	ns
	4Gb	110	-	110	-	ns
	8Gb	160	-	160	-	ns
	16Gb	260	-	260	-	ns
Note: 1. The maximum read preamble is bounded by tLZ(DQS)min on the left side and tDQSCK(max) on the right side. Boundary of DQS Low-Z occur one cycle earlier in 2tCK toggle mode. 2. DQ falling signal middle-point of transferring from High to Low to first rising edge of DQS diff-signal cross-point.						

Product Specifications		
PART NO.:	VL33A1H63F-N6S	REV: 1.0

Package Dimensions

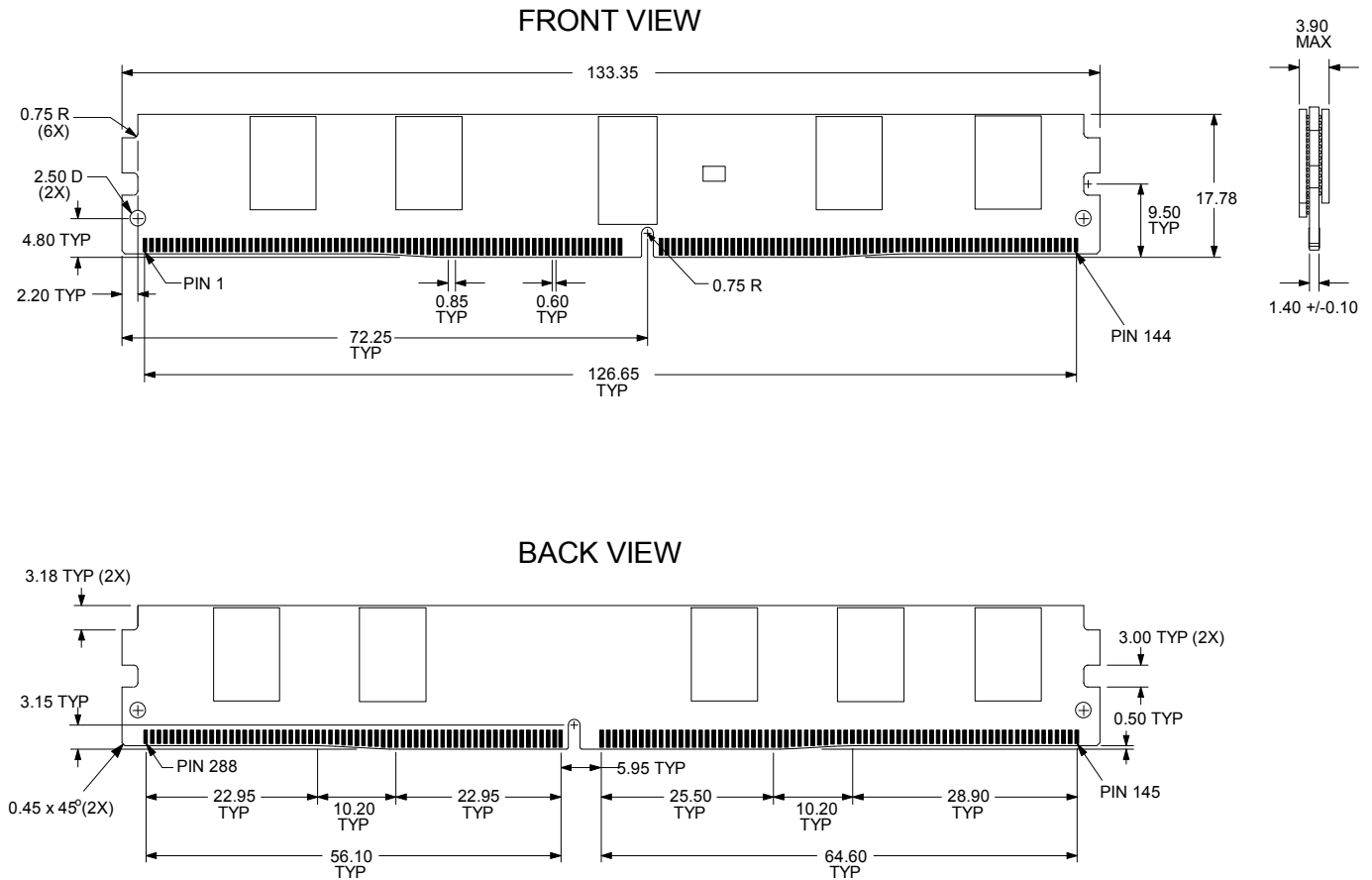

Notes: 1. All dimensions are in millimeters with tolerance +/- 0.15mm unless otherwise specified.
 2. The dimensional diagram is for reference only.