

Overview

KEMET's VM series of dual function protective devices protect against voltage surges in an automotive voltage region and against radio frequency noise. This component replaces two components – a low voltage varistor and a capacitor.

KEMET's VM series incorporate a varistor function in automotive applications in a voltage region of 12 V, 24 V and 42 V and a function of a radio-frequency filtering capacitor in a high capacitance range from 0.47 to 1.5 μF , making them ideal for protection in automobile electronic applications.

KEMET's VM series are square shaped components with in-line leads and require at least 30% less mounting space.

Applications

Typical applications include the protection against voltage transients and suppression of radio-frequency interference in automobile electronics including wiper motors, central locking systems, seat adjustment motors, seat heating and electric window systems.

Benefits

- Through-hole form factor
- Operating ambient temperature of -40°C to $+125^{\circ}\text{C}$
- Supply voltage of 12 V, 24 V and 42 V
- Operating voltage of 16 to 56 VDC
- Capacitance range at 1 kHz of 0.47 to 1.5 μF
- X7R capacitor temperature characteristics
- Dimensional and weight savings on the board
- RoHS 2 2011/65/EC, REACH compliant
- AEC-Q200 qualified Grade 1

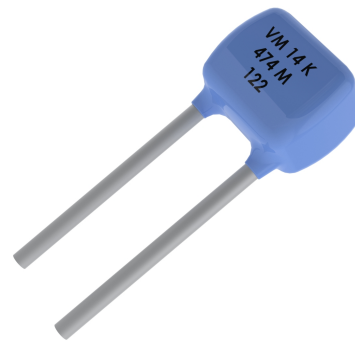

Ordering Information

VM	474	M	K	801	R	014	P050
Series	Capacitance Code (μF)	Capacitance Tolerance Code	Tolerance of Varistor Voltage	Maximum Surge Current Code	Packaging/Lead Style	Maximum Continuous Working Voltage (Vrms AC)	Pitch Code
Varistor Dual Function Leaded 125°C Automotive Grade Varistor/ Capacitor (X7R Dielectric)	474 = 0.47 105 = 1.0 155 = 1.5	M = ±20%	K = ±10%	801 = 800 A 122 = 1,200 A	B = Bulk /Straight Lead R = Reel /Straight Lead	12 V Power Supply 014 = 14 Vrms AC 017 = 17 Vrms AC 24 V Power Supply 020 = 20 Vrms AC 030 = 30 Vrms AC 42 V Power Supply 040 = 40 Vrms AC	P050 = 5mm P120 = 12mm

Dimensions – Millimeters

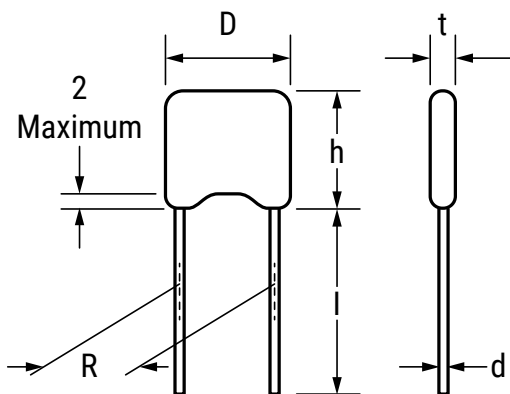

As per part number table.

Environmental Compliance

RoHS 2 2011/65/EC, REACH

Performance Characteristics

Continuous	Units	Value
Steady State Applied Voltage		
DC Voltage Range (V_{dc})	V	16 to 56
AC Voltage Range (V_{rms})	V	14 to 40
Transient		
Load Dump Energy, (WLD)	J	6 to 12
Non-Repetitive Surge Current, 8/20 μ s Waveform (I_{max})	A	800 to 1,200
Non-Repetitive Surge Energy, 10/1000 μ s Waveform (W_{max})	J	2.4 to 10.5
Capacitance Range	μ F	0.47 to 1.5
Capacitor Temperature Characteristics		X7R
Operating Ambient Temperature	°C	-40 to +125
Storage Temperature Range	°C	-40 to +150
Threshold Voltage Temperature Coefficient	%/°C	< + 0.05
Insulation Resistance	G Ω	> 1
Isolation Voltage Capability	kV	> 1.25
Response Time	ns	< 25
Climatic Category		40/125/56

Qualifications

Reliability Parameter	Test	Tested According to	Condition to be Satisfied after Testing
Voltage Proof	Vt	EN 132 400, Test 4.2.1. - the voltage shall be raised from near zero to the test voltage Vt at a rate not exceeding 150 V/s, Where for: Class X1 Capacitors Vt = 2*Vrms + 1,500 V~, 1 minute Class Y1 Capacitors Vt = 4000 V~, 1 minute Class Y2 Capacitors Vt = 2*Vrms + 1,500 V~, 1 minute	no permanent breakdown of flash-overs during the test period
Impulse Voltage		EN 132 400, Test 4.13. - 24 impulses of the same polarity shall be applied to the capacitor. The time between impulses shall be no less than 10s, where for: Class X1 Capacitors Vp = 4 kV Class Y1 Capacitors Vp = 8 kV Class Y2 Capacitors Vp = 5 kV	no self-healing breakdowns or flash-overs

Qualifications cont'd

Reliability Parameter	Test	Tested According to	Condition to be Satisfied after Testing
AC/DC Bias Reliability	AC/DC Life Test	EN 132 400, Test 4.14, 1000 h at UCT, where: - for X Class Capacitors: at $V = 1.25 V_{rms}$ and once per hour the voltage shall be increased to 1000 V~ for 0,1 s - for Y Class Capacitors: at $V = 1.7 V_{rms}$ and once per hour the voltage shall be increased to 1,000 V~ for 0,1 s	no visible damage $ \Delta C/C < 20\%$ $\tan \delta < 0.008$ IR greater than 50 % of the applicable limits no permanent breakdown or flash-over during voltage proof
Charge and Discharge		EN 132 400, Test 4.15. - 10.000 cycles of charge and discharge at the rate of one operation per minute with the test voltage of $\sqrt{2} * V_{rms}$ discharge rate adjusted to 100 V/ μ s	$ \Delta C/C < 10\%$ $\tan \delta < 0,008$ IR greater than 50 % of the applicable limits
Radio – Frequency Characteristics		EN 132 400, Test 4.16. - measurement of capacitor impedance over a range of frequencies	with specification
Capacitance – Temperature Characteristics		Measurement of capacitance and $\tan \delta$ in the temperature chamber at 20 °C and at UCT and LTC	with specification
Environmental and Storage Reliability	Climatic Sequence	EN 132 400, Test 4.11 a) Dry heat, 16 h, UCT, Test Ba, IEC 68–2–2 b) Damp heat, cyclic, the first cycle: 55°C, 93 % RH, 24 H, test DB, IEC 68–2–1 c) Cold, LCT, 2 h, Test Aa, IEC 68–2–1 d) Damp heat cyclic, remaining 5 cycles: 55°C, 93 % RH, 24 h/cycle, Test Bd, IEC 68–2–30	no visible damage $ \Delta C/C < 20\%$ $\tan \delta < 0.008$ IR greater than 50 % of the applicable limits no permanent breakdown or flash-over during voltage proof
	Thermal Shock	EN 132 400, Test 4.6, Test Na, IEC 68–2–14, 5 cycles UCT/LCT, 30 minutes	no visible damage
	Steady State Damp Heat	EN 132 400, Test 4.6, Test Na, IEC 68–2–14, 5 cycles UCT/LCT, 30 minutes	no visible damage $ \Delta C/C < 20\%$ $\tan \delta < 0.008$ IR greater than 50 % of the applicable limits no permanent breakdown or flash-over during voltage proof
	Storage Test	ICE 68–2–2, Test Ba 1,000 h at maximum storage temperature	no visible damage $ \Delta C/C < 20\%$ $\tan \delta < 0.008$ IR greater than 50 % of the applicable limits no permanent breakdown or flash-over during voltage proof
Mechanical Reliability	Solderability	EN 132 400, Test 4.5., Test Ta, IEC 68–2–20, solder bath and reflow method	Solderable at shipment and after 2 years of storage - limits
	Resistance to Soldering Heat	EN 132 400, Test 4.4., Test Tb, IEC 68–2–20, solder bath and reflow method	no visible damage $ \Delta C/C < 10\%$
	Robustness of Termination	EN 132 400, Test 4.3., Test Ua, IEC 68–2–21	no visible damage
	Vibration	EN 131 400, Test 4.7., Test Fc, IEC 68–2–6, Frequency range 10 to 55 Hz; Amplitude 0.75 mm or 98 m/s ² Total duration 6 h (3 x 2 h); Waveshape – half sine	no visible damage
	Mechanical Shock	EN 132 400, Test 4.9, Test Ea, IEC 68–2–27 Acceleration = 490 m/s ² ; 100 g 6ms and 50 g 11 ms Waveshape – half sine; Number of shocks = 3 x 6	" $ \Delta C/C < 10\%$ $\tan \delta$ within specification no visible damage"

Application Circuit

Provides for the elimination of transients and EMI noise in automotive electronics such as engine control, exhaust gas control, safety systems, etc. against disturbances caused by small motors used in automobiles. Most frequently, small motors in an automobile are those used for windscreen wipers, window mechanisms, seat adjustments and automatic door locking.

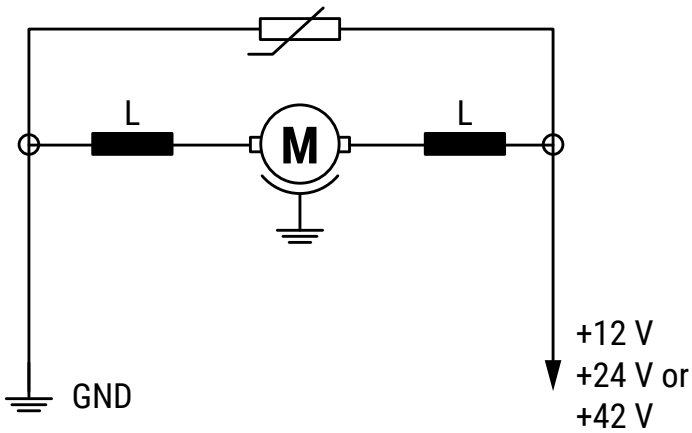

Table 1 – Ratings & Part Number Reference

KEMET Part Number	D _{max} (mm)	A _{max} (mm)	R (mm)	t _{max} (mm)	V _{rms}	VDC	V _n 1 mA	V _{jump} 5 min.	V _c	I _c (A)	W _{max} 10/1000 μs (J)	WLD 10 x (J)	P _{max} (W)	I _{max} 8/20 μs (A)	C _{typ} at 1 kHz (μF)
12 V Power Supply															
VM474MK801(1)014P050	7.5	9	5	5.5	14	16	24	24.5	40	5	2.4	6	0.015	800	0.47
VM105MK801(1)014P050	7.5	9	5	5.5	14	16	24	24.5	40	5	2.4	6	0.015	800	1.00
VM155MK801(1)014P050	7.5	9	5	5.5	14	16	24	24.5	40	5	2.4	6	0.015	800	1.50
VM474MK122(1)014P050	8.0	12	5	5.5	14	16	24	24.5	40	10	5.8	12	0.03	1200	0.47
VM105MK122(1)014P050	8.0	12	5	5.5	14	16	24	24.5	40	10	5.8	12	0.03	1200	1.00
VM155MK122(1)014P050	8.0	12	5	5.5	14	16	24	24.5	40	10	5.8	12	0.03	1200	1.50
VM474MK801(1)017P050	7.5	9	5	5.5	17	20	27	30	44	5	2.8	6	0.015	800	0.47
VM105MK801(1)017P050	7.5	9	5	5.5	17	20	27	30	44	5	2.8	6	0.015	800	1.00
VM155MK801(1)017P050	7.5	9	5	5.5	17	20	27	30	44	5	2.8	6	0.015	800	1.50
VM474MK122(1)017P050	8.0	12	5	5.5	17	20	27	30	44	10	7.4	12	0.030	1200	0.47
VM105MK122(1)017P050	8.0	12	5	5.5	17	20	27	30	44	10	7.4	12	0.030	1200	1.00
VM155MK122(1)017P050	8.0	12	5	5.5	17	20	27	30	44	10	7.4	12	0.030	1200	1.50
24 V Power Supply															
VM474MK801(1)020P050	7.5	9	5	5.5	20	26	33	36	54	5	3.2	6	0.015	800	0.47
VM105MK801(1)020P050	7.5	9	5	5.5	20	26	33	36	54	5	3.2	6	0.015	800	1.00
VM155MK801(1)020P050	7.5	9	5	5.5	20	26	33	36	54	5	3.2	6	0.015	800	1.50
VM474MK122(1)020P050	8.0	12	5	5.5	20	26	33	36	54	10	7.8	12	0.03	1200	0.47
VM105MK122(1)020P050	8.0	12	5	5.5	20	26	33	36	54	10	7.8	12	0.030	1200	1.00
VM155MK122(1)020P050	8.0	12	5	5.5	20	26	33	36	54	10	7.8	12	0.030	1200	1.50
VM474MK801(1)030P050	7.5	9	5	5.5	30	38	47	50	77	5	4.5	6	0.015	800	0.47
VM105MK801(1)030P050	7.5	9	5	5.5	30	38	47	50	77	5	4.5	6	0.015	800	1.00
VM155MK801(1)030P050	7.5	9	5	5.5	30	38	47	50	77	5	4.5	6	0.015	800	1.50
VM474MK122(1)030P050	8.0	12	5	5.5	30	38	47	50	77	10	10.0	12	0.030	1200	0.47
VM105MK122(1)030P050	8.0	12	5	5.5	30	38	47	50	77	10	10.0	12	0.030	1200	1.00
VM155MK122(1)030P050	8.0	12	5	5.5	30	38	47	50	77	10	10.0	12	0.030	1200	1.50
42 V Power Supply															
VM474MK801(1)040P050	7.5	9	5	5.5	40	56	68	65	110	5	4.8	6	0.015	800	0.47
VM105MK801(1)040P050	7.5	9	5	5.5	40	56	68	65	110	5	4.8	6	0.015	800	1.00
VM155MK801(1)040P050	7.5	9	5	5.5	40	56	68	65	110	5	4.8	6	0.015	800	1.50
VM474MK122(1)040P050	8.0	12	5	5.5	40	56	68	65	110	10	10.5	12	0.030	1200	0.47
VM105MK122(1)040P120	8.0	12	12	5.5	40	56	68	65	110	10	10.5	12	0.030	1200	1.00
VM155MK122(1)040P120	8.0	12	12	5.5	40	56	68	65	110	10	10.5	12	0.030	1200	1.50

(1) Insert packaging/lead Style code. See Ordering Options Table for available options.

Soldering

Very often before soldering through-hole components, their leads get bent. It is important not to damage the component during lead bending. Typical damage incurred during bending is cracks in epoxy parts, which can lead to increased humidity sensitivity of a component and consequentially to a shorter life time.

In order to avoid epoxy parts damage it is necessary to:

- fix the most sensitive point (epoxy parts) of a component body
- bend the wire at least 2 mm below the end of epoxy parts

Other potential damage to a component which can lead to component failure or a shorter life time is thermal shock during manual soldering with a soldering iron. This can occur in the case when a soldering iron is placed too close to one point of the component body and most often it happens if the solder joint is too close to the varistor body.

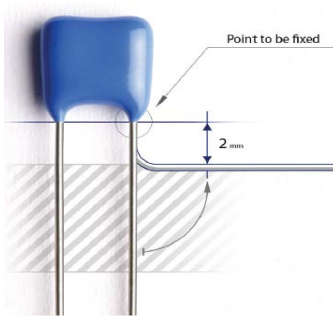

Resistance to Soldering Heat – In the case of automatic wave soldering, it is important to provide sufficient resistance to soldering heat. In order to prevent any potential problems the standard for testing the resistance to soldering heat of through-hole components is 300°C, 10s.

Pb-free Wave Soldering Profile Recommendations – Recommended soldering profiles for all above components are in accordance with JEDEC standard curves (J-STD-020D) and therefore compatible with the new Pb-free process.

Soldering (cont'd)

Lead-free Wave Soldering Profile

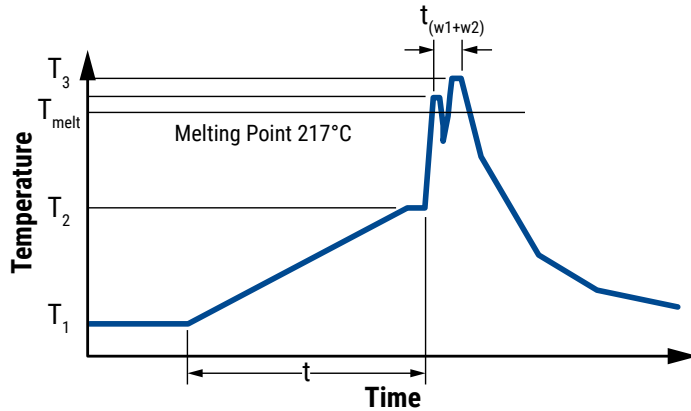

Parameters	Symbol	Specification
Preheating temperature gradient		4°C/s maximum
Preheating time	t_1	2 to 5 minutes
Minimum preheating temperature	T_1	130°C
Maximum preheating temperature	T_2	180°C
Melting temperature/point	T_{melt}	217°C
Time in wave soldering phase (w1+w2)	t_{w1+w2}	10 seconds
Maximum wave temperature (w1+w2)	T_3	265°C +0/-5°C
Cooling temperature gradient		6°C/seconds maximum
Temperature jump from T_2 to T_3 (w1)	$T_3(w1) - T_3(w1) - T_2$	120°C maximum
Time from 25°C to T_3 (wave temperature)		8 minutes maximum

Packaging

B	R
1,000	1,000

Construction

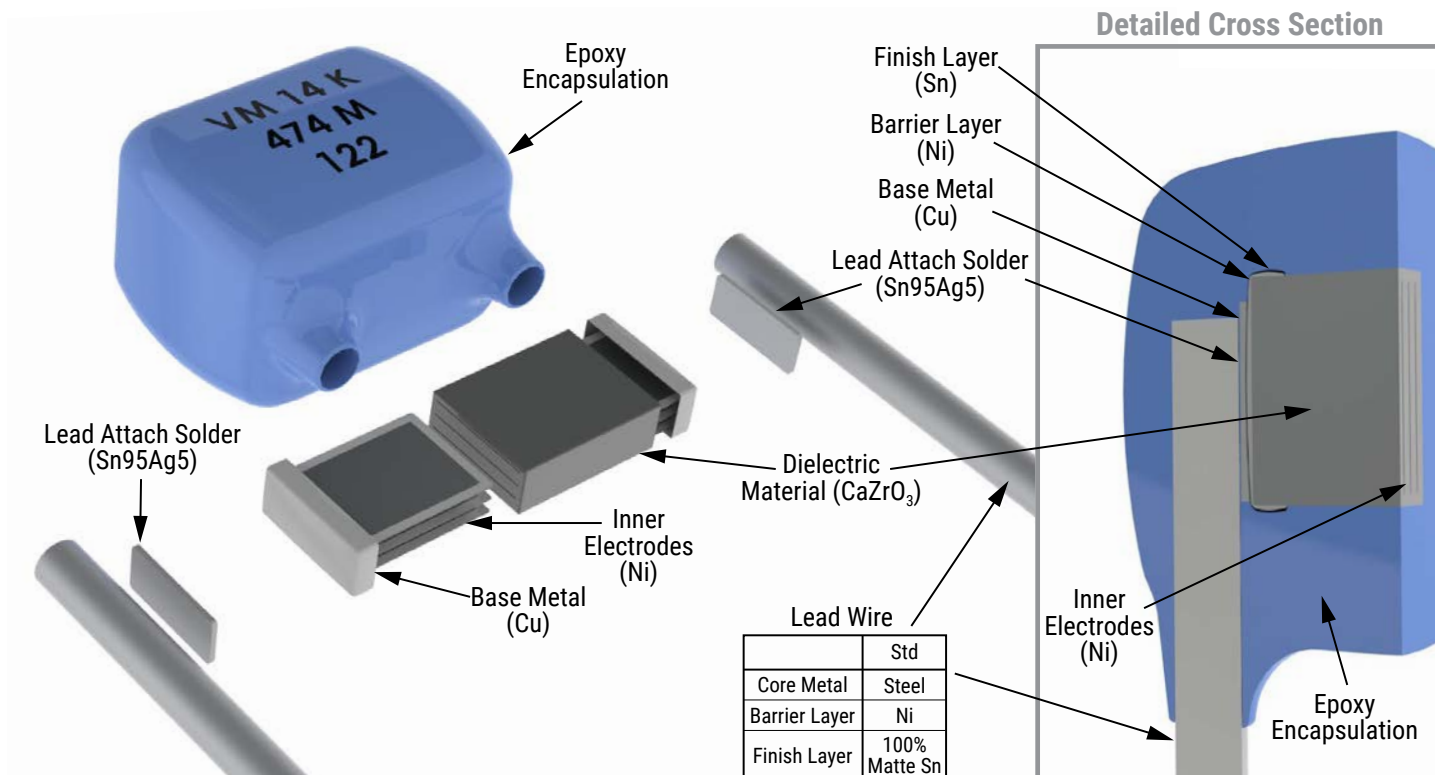

Capacitor Marking

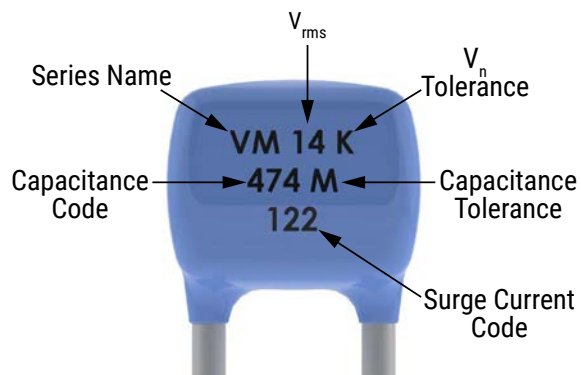

Taping & Reel Specifications

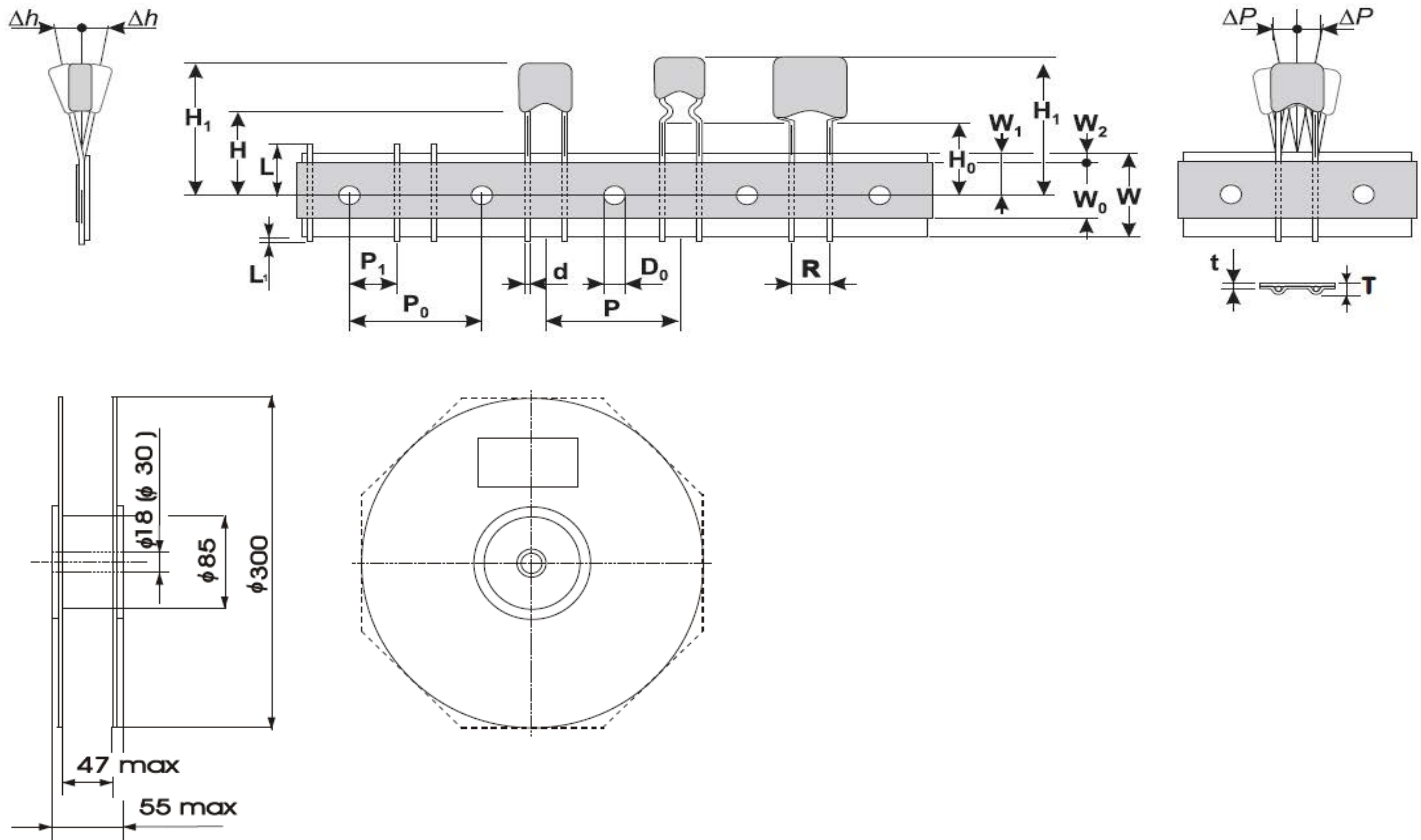

Symbol	Parameter	Dimension (mm)
W	Carrier tape width	18+1.0/-0.5
W ₀	Hold down tape width	5 minimum
W ₁	Sprocket hole position	9+0.75/-0.5
W ₂	Distance between the upper edges of the carrier tape and hold-down tape	3 maximum
T	Total tape thickness	1.5 maximum
t	Tape thickness	0.9 maximum
P	Pitch of component	12.7±1.0
P ₀	Feed hole pitch	12.7±0.3
P ₁	Feed hole center to pitch	3.85±0.7
R	Lead Spacing	5+0.5/-0.2
ΔP	Component alignment	±1.3 maximum
Δh	Component alignment	±2 maximum
d	Wire diameter	0.6 maximum
D ₀	Feed hole diameter	4±0.2
H	Height from tape center to comp. base	18+2.0/-0.0
H ₀	Seating plane height	16±0.5
H ₁	Component height	32.2 maximum
L	Protrusion – cut out	11 maximum
L ₁	Protrusion – cut off	0.5 maximum

Note: Table for R = 5 mm only. Dimensions for R = 12 mm available on request

Terms and Definitions

Term	Symbol	Definition
Rated AC Voltage	V_{rms}	Maximum continuous sinusoidal AC voltage (<5% total harmonic distortion) which may be applied to the component under continuous operation conditions at 25°C
Rated DC Voltage	V_{dc}	Maximum continuous DC voltage (<5% ripple) which may be applied to the component under continuous operating conditions at 25°C
Supply Voltage	V	The voltage by which the system is designated and to which certain operating characteristics of the system are referred; $V_{rms} = 1,1 \times V$
Leakage Current	I_{dc}	The current passing through the varistor at V_{dc} and at 25°C or at any other specified temperature
Varistor Voltage	V_n	Voltage across the varistor measured at a given reference current I_n
Reference Current	I_n	Reference current = 1 mA DC
Clamping Voltage Protection Level	V_c	The peak voltage developed across the varistor under standard atmospheric conditions, when passing an 8/20 μs class current pulse
Class Current	I_c	A peak value of current which is 1/10 of the maximum peak current for 100 pulses at two per minute for the 8/20 μs pulse
Voltage Clamping Ratio	V_c/V_{app}	A figure of merit measure of the varistor clamping effectiveness as defined by the symbols V_c/V_{app} , where ($V_{app} = V_{rms}$ or V_{dc})
Jump Start Transient	V_{jump}	The jump start transient resulting from the temporary application of an overvoltage in excess of the rated battery voltage. The circuit power supply may be subjected to a temporary overvoltage condition due to the voltage regulation failing or it may be deliberately generated when it becomes necessary to boost start the car
Rated Single Pulse Transient Energy	W_{max}	Energy which may be dissipated for a single 10/1000 μs pulse of a maximum rated current, with rated AC voltage or rated DC voltage also applied, without causing device failure
Load Dump Transient	WLD	Load Dump is a transient which occurs in an automotive environment. It is an exponentially decaying positive voltage which occurs in the event of a battery disconnect while the alternator is still generating charging current with other loads remaining on the alternator circuit at the time of battery disconnect
Rated Peak Single Pulse Transient Current	I_{max}	Maximum peak current which may be applied for a single 8/20 μs pulse, with, rated line voltage also applies, without causing device failure
Rated Transient Average Power Dissipation	P	Maximum average power which may be dissipated due to a group of pulses occurring within a specified isolated time period, without causing device failure at 25°C
Capacitance	C	Capacitance between two terminals of the varistor measured at at 1 kHz
Response Time	t_r	The time lag between application of a surge and varistor's "turn-on" conduction action
Varistor Voltage Temperature Coefficient	TC	$(V_n \text{ at } 85^\circ\text{C} - V_n \text{ at } 25^\circ\text{C}) / (V_n \text{ at } 25^\circ\text{C}) \times 60^\circ\text{C} \times 100$
Insulation Resistance	IR	Minimum resistance between shorted terminals and varistor surface
Isolation Voltage		The maximum peak voltage which may be applied under continuous operating conditions between the varistor terminations and any conducting mounting surface
Operating Temperature		The range of ambient temperature for which the varistor is designed to operate continuously as defined by the temperature limits of its climatic category
Climatic Category	LCT/UCT/DHD	UCT = Upper Category Temperature – the maximum ambient temperature for which a varistor has been designed to operate continuously, LCT = Lower Category Temperature – the minimum ambient temperature at which a varistor has been designed to operate continuously DHD = Dump Heat Test Duration
Storage Temperature		Storage temperature range without voltage applied