

VM880C Datasheet

Embedded Video Engine

Credit Card Board

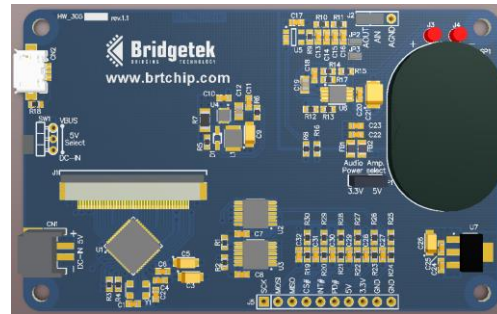

1 Introduction

The VM880C is a development module for BT880, which is used to develop and demonstrate the functionality of the BT880 Embedded Video Engine, EVE. This module behaves as an SPI slave and requires an SPI Master for proper micro-controller interfacing and system integration.

VM880C module supports display, touch and audio interfaces. Users can choose to connect to different LCD screens as long as they meet the BT880 technical specification and fit the VM880C LCD connector. Typical TFT displays supported:

- 4.3" 480x272 TFT LCD with 40-pin FPC
- 5" 480x272 TFT LCD with 40-pin FPC

1.1 Features

The VM880C utilises the BT880 Embedded Video Engine. Graphic, audio and touch features of the BT880 can be accessed with the VM880C. For a full list of the BT880's features please see the BT88x datasheet.

The VM880C has the following features:

- 40-pin FPC connector for TFT LCD and resistive touch screen
- On board LCD backlight LED Driver
- Supports mono audio output
- On board audio power amplifier and micro speaker
- Flexible power supply. Powering the VM880C using SPI host connector, or via USB Micro-B port, or via a 2.0mm JST connector
- 5V tolerant buffers when used with a 5V SPI Master.

Neither the whole nor any part of the information contained in, or the product described in this manual, may be adapted or reproduced in any material or electronic form without the prior written consent of the copyright holder. This product and its documentation are supplied on an as-is basis and no warranty as to their suitability for any particular purpose is either made or implied. Bridgetek Pte Ltd will not accept any claim for damages howsoever arising as a result of use or failure of this product. Your statutory rights are not affected. This product or any variant of it is not intended for use in any medical appliance, device or system in which the failure of the product might reasonably be expected to result in personal injury. This document provides preliminary information that may be subject to change without notice. No freedom to use patents or other intellectual property rights is implied by the publication of this document. Bridgetek Pte Ltd, 178 Paya Lebar Road, #07-03, Singapore 409030. Singapore Registered Company Number: 201542387H

2 Ordering Information

Part No.	Description
VM880C	Credit Card Size VM880C module, supports 3.3/5v signal levels to MCU Adapter Board, with FPC/FFC 40 LCD connector. No display is provided.

Table 2-1 – Ordering information

Table of Contents

1	Introduction	1
1.1	Features	1
2	Ordering Information	2
3	Hardware Description	4
3.1	VM880C board.....	4
3.2	Physical Descriptions	5
3.2.1	PCB layout.....	5
3.2.2	VM880C Connectors.....	6
4	Board Schematics.....	9
5	Hardware Setup Guide	11
5.1	Power Configuration	11
5.2	Backlight LED current Configuration	11
5.3	MPSSE Setup.....	11
6	Mechanical Dimensions	14
7	Contact Information.....	15
	Appendix A – References	16
	Document References	16
	Acronyms and Abbreviations.....	16
	Appendix B - List of Figures and Tables	17
	List of Figures	17
	List of Tables.....	17
	Appendix C – Revision History	18

3 Hardware Description

Please refer to section 3.2.2 for connector settings. Some VM880C jumpers must be set to work properly with your system.

3.1 VM880C board

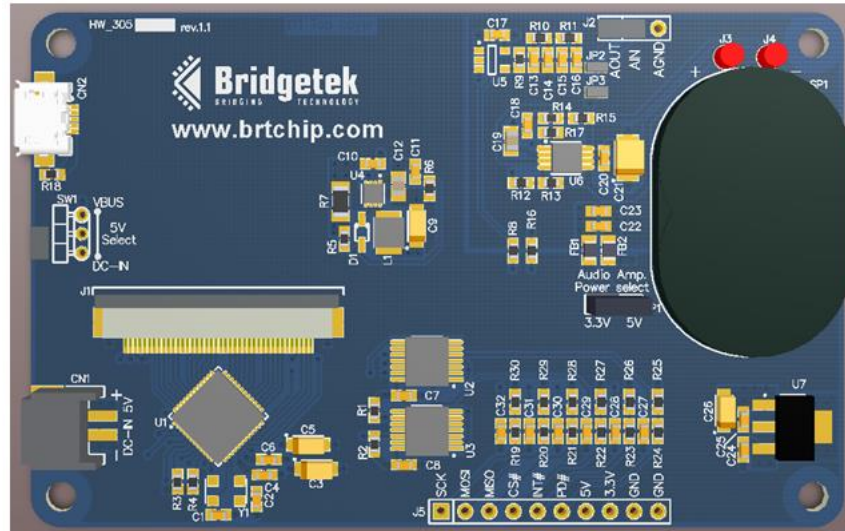

Figure 3-1 – VM880C board top view

The VM880C module is intended for direct use into existing applications that require a display. This module is suitable for interfacing with an external microcontroller that has an SPI Master channel.

The main functions of the VM880C are as follows:

- Micro USB, SPI connector or 2-pin connector for power supply
- 3.3V regulator: Takes 5V input and outputs 3.3V for on-board circuits
- LCD backlight driver. On board back light driver has over voltage protection (OVP) of 34V and drive current 40mA.
- 5V tolerant buffers between the SPI master interface and the Slave interface of the BT880
 - SPI timing requirements can be referenced in the BT880 [datasheet](#). The on-board level converter buffers introduce additional delay. The actual maximum SPI clock frequency depends on the host system timing and connection cable length to the VM880C.
- 3 stage audio filter and power amplifier
- 8Ω speaker
- Audio line out option

3.2 Physical Descriptions

3.2.1 PCB layout

The VM880C is an 85.6mm x 54.1mm, four-layer printed circuit board. The board's thickness is approximately 1.6mm.

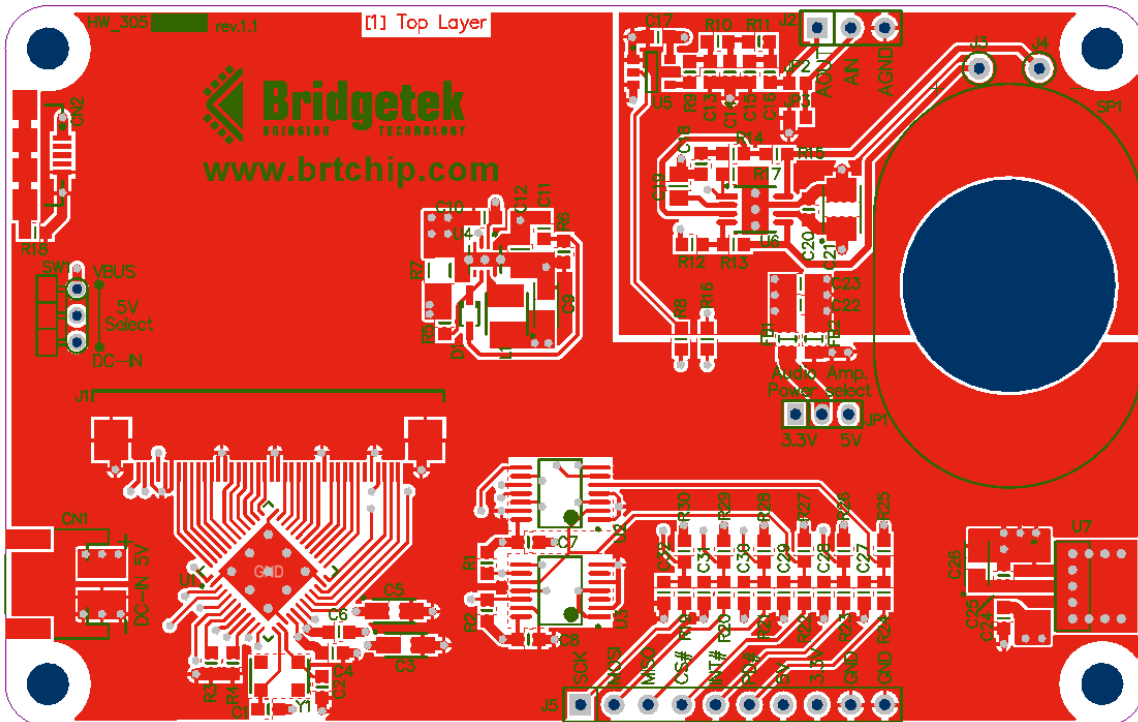

Figure 3-2 – VM880C board top layer

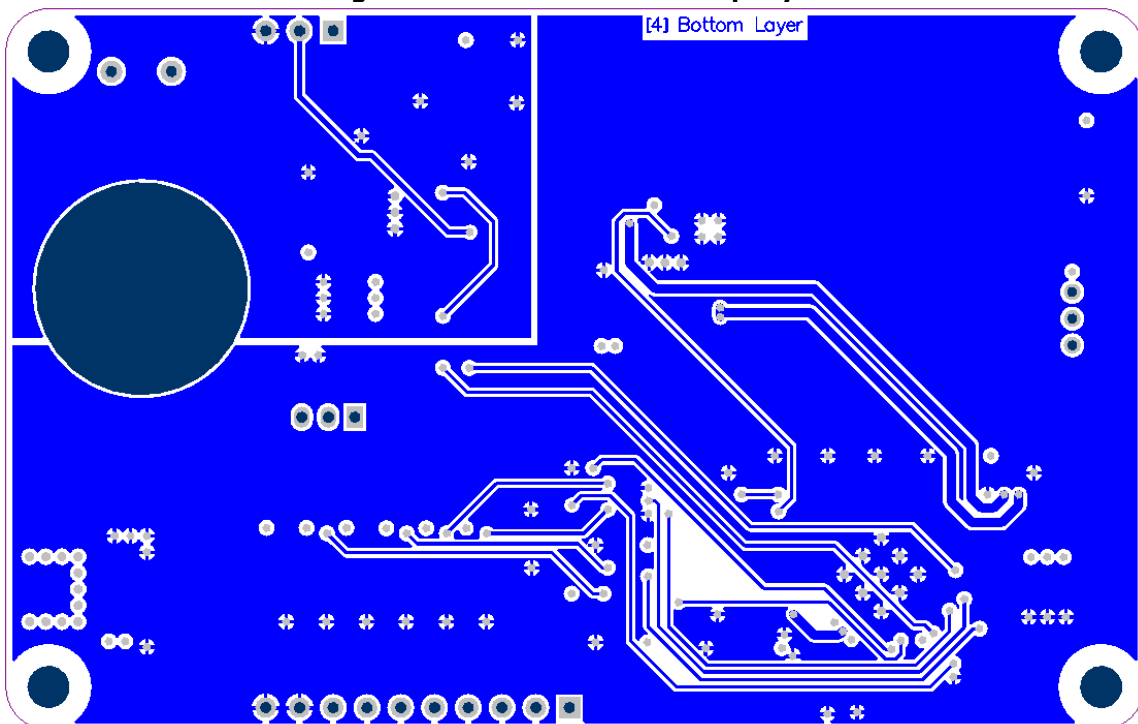

Figure 3-3 – VM880C board bottom layer

3.2.2 VM880C Connectors

Connectors and jumpers are described in the following sections.

- **CN1- 2-pin power connector**

2 pin JST connector for 5V power input to the board. Alternative to Micro USB connector.

Pin No.	Name	Type	Description
1	VCC	P	5V power supply
2	GND	P	Ground

Table 3-1 – CN1 Pinout

- **CN2- Micro USB Receptacle**

This receptacle is strictly for 5V input to power the board. There is no USB Functionality

Pin No.	Name	Type	Description
1	VBUS	P	5V power supply
2	NC	NA	No connection
3	NC	NA	No connection
4	NC	NA	No connection
5	GND	P	Ground

Table 3-2 – CN2 Pinout

- **J1- LCD Flex Cable connector**

This connector is the interface between the BT880 IC and the LCD Module.

Signal	Pin No	Description
LED K	1	LED-
LED A	2	LED+
DISP	31	LCD Display Enable
HSYNC	32	LCD Horizontal Sync
VSYNC	33	LCD Vertical Sync
DCLK	30	LCD Pixel Clock
DE	34	LCD Data Enable
R2	7	Bit 2 of Red RGB signals
R3	8	Bit 3 of Red RGB signals
R4	9	Bit 4 of Red RGB signals
R5	10	Bit 5 of Red RGB signals
R6	11	Bit 6 of Red RGB signals
R7	12	Bit 7 of Red RGB signals
G2	15	Bit 2 of Green RGB signals
G3	16	Bit 3 of Green RGB signals
G4	17	Bit 4 of Green RGB signals
G5	18	Bit 5 of Green RGB signals
G6	19	Bit 6 of Green RGB signals
G7	20	Bit 7 of Green RGB signals
B2	23	Bit 2 of Blue RGB signals
B3	24	Bit 3 of Blue RGB signals
B4	25	Bit 4 of Blue RGB signals
B5	26	Bit 5 of Blue RGB signals
B6	27	Bit 6 of Blue RGB signals
B7	28	Bit 7 of Blue RGB signals
XP	37	touch panel X right
YM	38	touch panel Y down
XM	39	touch panel X left
YP	40	touch panel Y up

Signal	Pin No	Description
3V3	4	3V3 Power
GND	3,5,6,13,14,21,22,29,36	Ground
NC	35	No connect

Table 3-3 – J1 Pinout

- **J2 - Selection between lineout or loop back into the power amplifier.**

Selection between audio lineout or loop back into the power amplifier. JP2 next to J2 is connected by default for on board amplifier and on-board mini speaker. If J2 is used for audio output selection, JP2 needs to be removed. Note: do not short pin2 and pin3 of J2.

Pin No.	Name	Description
1	Audio line out	Use pin 1 and 3 for BT880 audio line out to external speaker
2	Audio line in	Short pin1 and 2 to loopback BT880 audio into the on-board power amplifier
3	Audio GND	Audio GND

Table 3-4 – J2 Pin Options

- **J3 – SP+**

Audio speaker +ve from the on-board amplifier.

- **J4 – SP-**

Audio speaker -ve from the on-board amplifier.

- **J5- SPI Interface**

This is the interface where the SPI control and data signals are routed. There are also power and ground pins on this interface. Note J5 is not soldered on the VM880C board by default.

Pin No.	Name	Type	Description
1	SCLK	I	SPI Clock input
2	MOSI	I	Master Out Slave in
3	MISO	O	Master In Slave out
4	CS#	I	Chip select, active low
5	INT#	OD	Host interrupt open drain output, active low. On board 47kΩ pull-up to 3.3V.
6	PD#	I	Active low power down input.
7	5V	P	5V power supply input
8	3.3V	P	3.3V power supply output. Can be used to power host board. Maximum output current 300mA (depends on 5V input source and LCD panel used).
9	GND	P	Ground
10	GND	P	Ground

Table 3-5 – J5 Pinout

- **JP1- Audio Amplifier Power Select**

This jumper provides the option to select the power supply voltage for the on-board power amplifier.

Pin No.	Name
1-2	3V3 selected (default, recommended)
2-3	5V selected

Table 3-6 – JP1 Pin options

*This needs to be configured before audio can be heard.

- **JP2 – On board amplifier enable**

Solder connection fitted by default.

- **JP3 - On board amplifier mute**

Solder connection not fitted by default. Do not fit this solder connection.

- **SW1 – Power source select**

Pin No.	Name
1-2	Power from CN1
2-3	Power from CN2

Table 3-7 – JP1 Pin options

4 Board Schematics

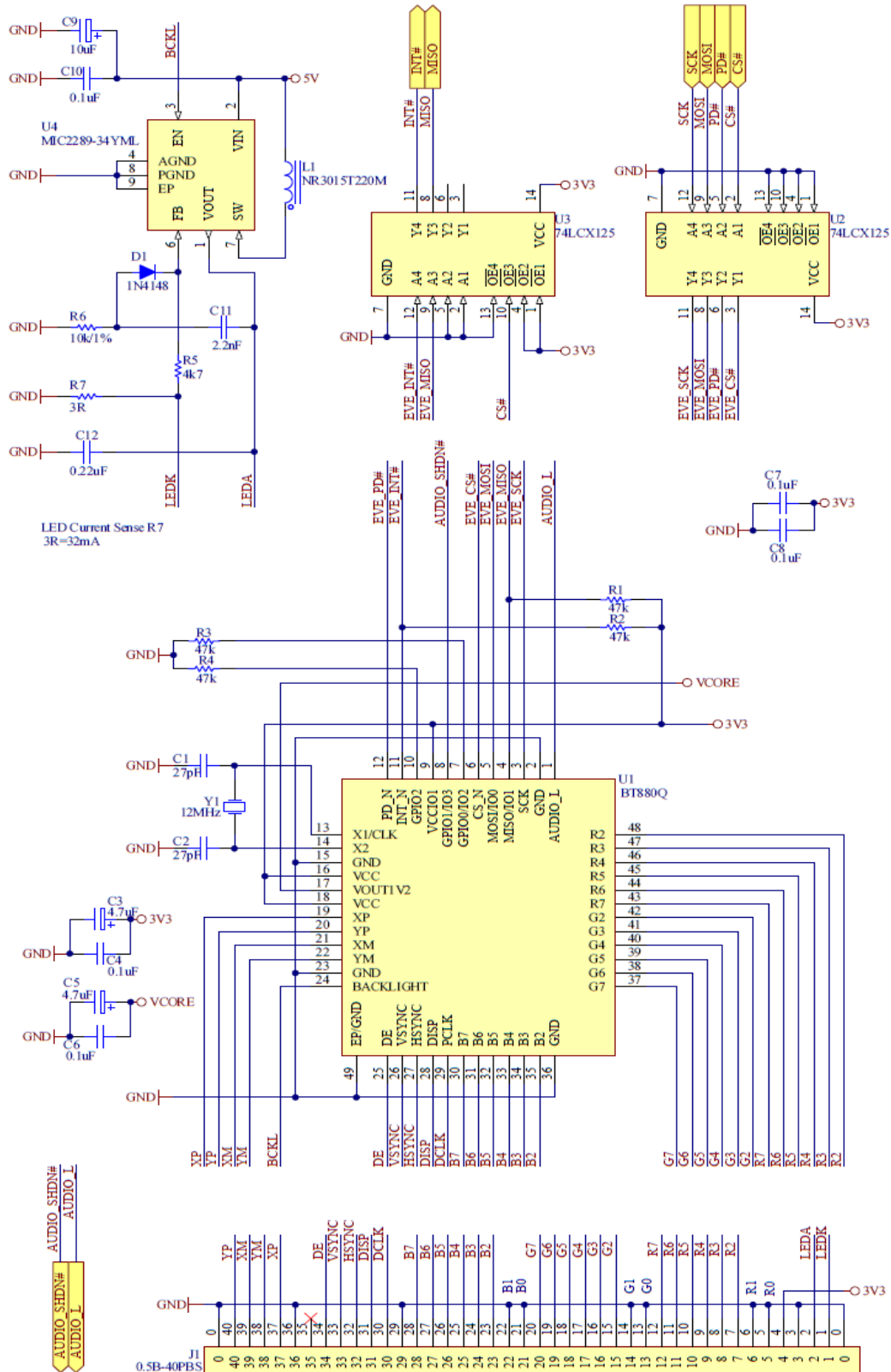

Figure 4-1 - BT880 and LCD circuit

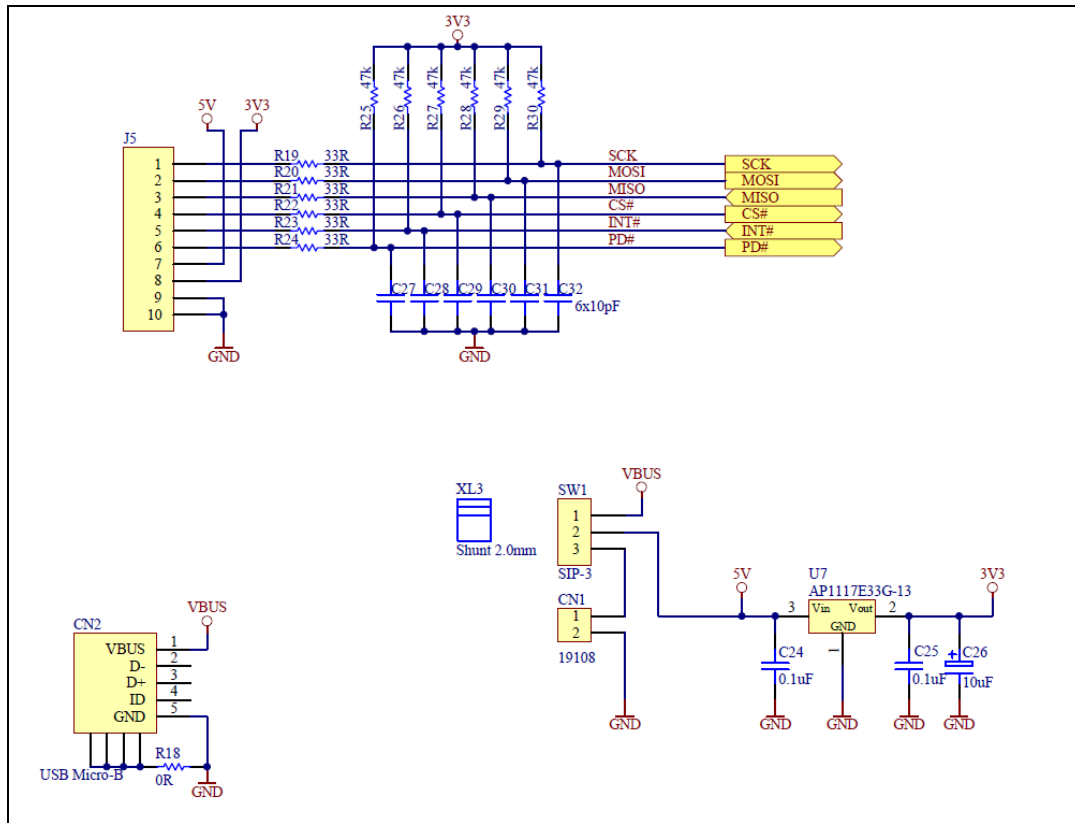

Figure 4-2 – SPI Interface Circuit

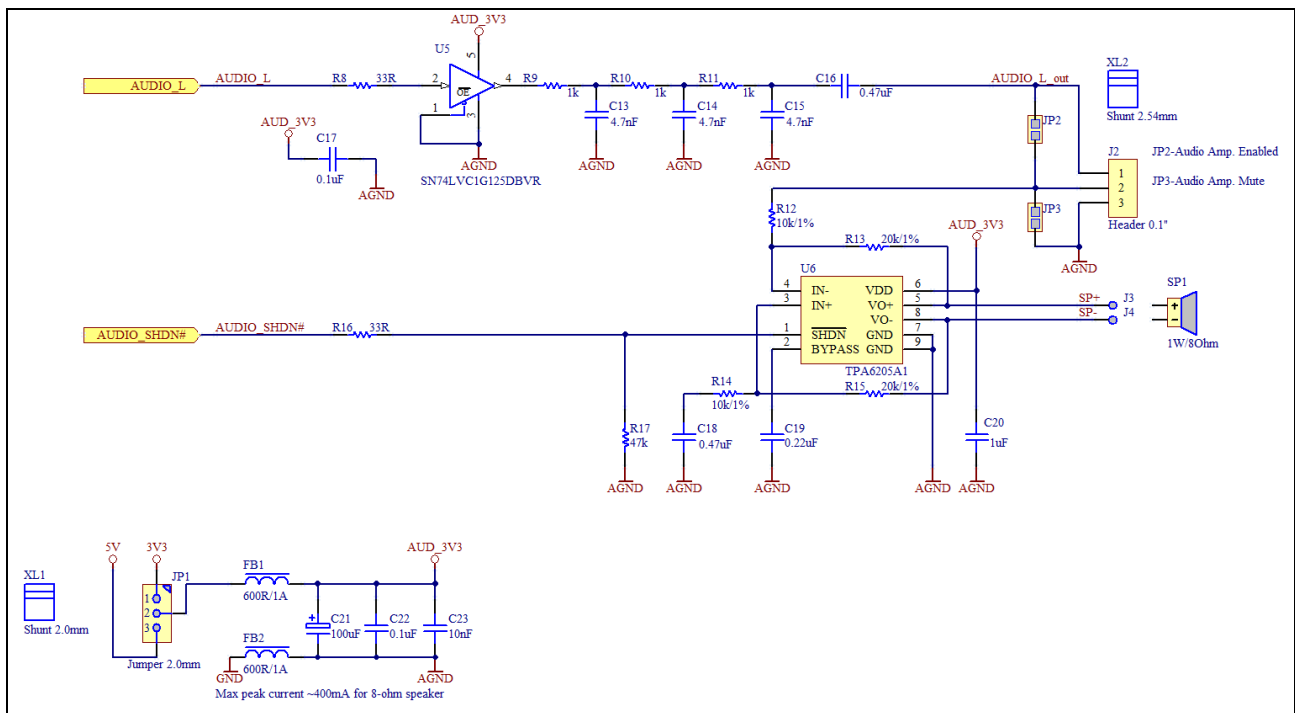

Figure 4-3 – Audio Circuit

5 Hardware Setup Guide

5.1 Power Configuration

There are 3 methods of powering the VM880C board.

- 1) USB Power(5V) - Connect USB power through micro-USB cable to CN2
- 2) DC IN(5V) - Connect 5V to CN1
- 3) J5 Power(5V) - Connect 5V to J5 pin 7

The following table summarises how to power the VM880C board using the various methods.

Power Method	CN2	CN1	J5 Pin 7	SW1
USB Power	5V	N/C	N/C	Short pin 2-3
DC IN(5V)	N/C	5V	N/C	Short pin 1-2
J5 Power(5V)	N/C	N/C	5V	Any Position

Table 5-1 – Board power configuration

Ensure that the power source is able to provide sufficient current for the module. The power consumption will vary depending on the LCD used but may be in excess of 500mA when the backlight and audio are operating. For an application using a 4.3" or 5" LCD, a 5V/1A supply is recommended if on-board audio amplifier/speaker is used, or 5V/0.5A supply if on-board audio amplifier/speaker is not used.

5.2 Backlight LED current Configuration

The VM880C module has a backlight LED driver circuit on-board. The input power source for the driver is 5V, and it regulates the output voltage to ensure that the backlight LED chain draws a total output current of 40mA. This works fine with a 4.3" WQVGA LCD with 12 white LED backlights in 2 sets of 6 series LEDs.

When the user selects an LCD panel to use with the VM880C board, the backlight LED current may need to be re-configured to suit the LCD panel. By replacing the resistor R7 on VM880C PCB, the backlight LED current can be changed. The value of R7 is determined by following formula:

$$R7 = 95\text{mV} / I_{\text{LED}}$$

5.3 MPSSE Setup

To give a quick start with the VM880C development board, a Windows based Sample Application and demo applications are provided for users to experiment and experience the BT880 in the VM880C system. The following paragraphs provide a short description for development procedures.

MPSSE is a "multi-purpose synchronous serial engine" interface available in some FTDI devices (e.g., FT232H, FT2232H and FT4232H). This engine allows users to bridge from a USB port on a PC to an SPI interface. Sample code is available for driving the BT880 over this interface with a FT232H device that has been integrated into a cable. This device is available in the VA800A-SPI board, or USBC-HS-MPSSE-5V-3.3V-500-SPR(5V) cable or USBC-HS-MPSSE-3.3V-3.3V-500-SPR(3.3V) cable.

More information about MPSSE cables may be found at:

<https://connectiveperipherals.com/products/usb-type-c-high-speed-mpsse?variant=37184462487703> .

In this section it is assumed the 5V version of the MPSSE cable is used. If the 3.3V version of the MPSSE cable is available, the setup is similar except for the power pin connection which requires an additional 5V power source to connect to CN2 or CN1. Refer to table 5-1 for board power configuration.

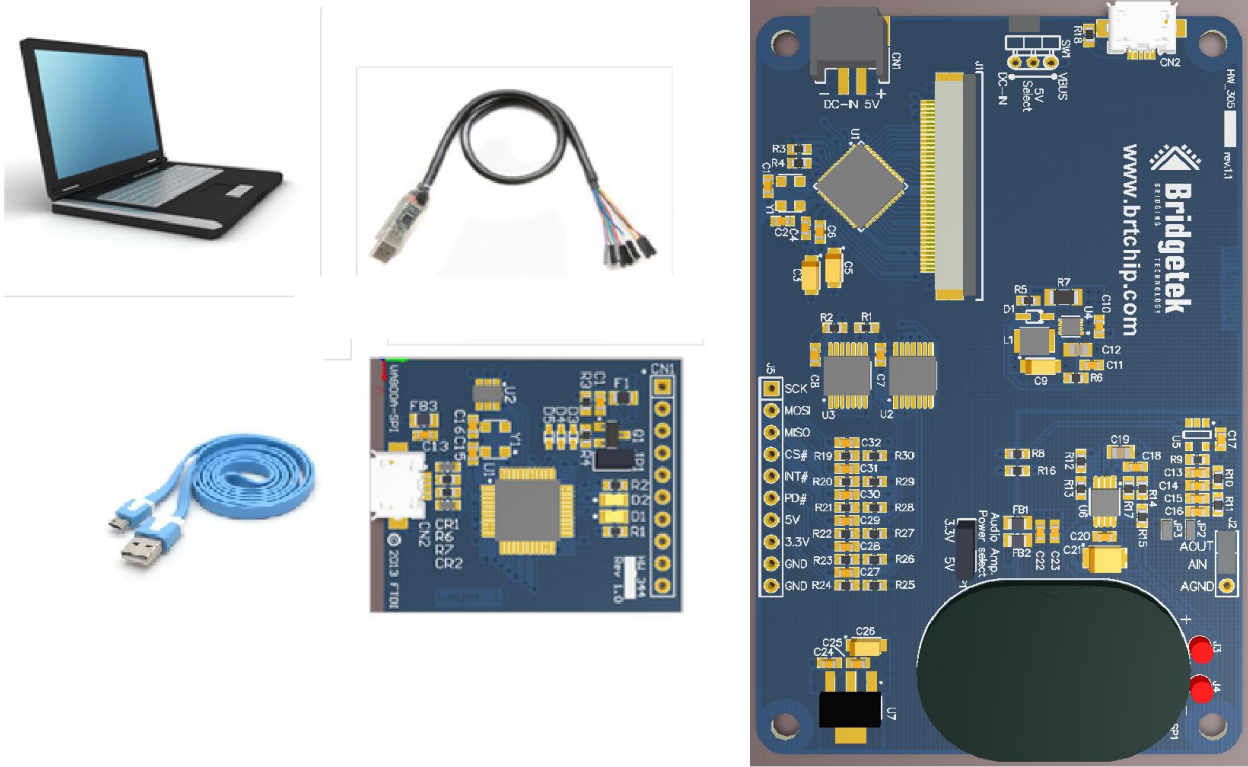

Figure 5-1 – VM880C connects to PC via VA800A-SPI or MPSSE cable

Hardware Setup VA800A-SPI

- Solder a 10-position single row pin header to J5 footprint of the VM880C board.
- Connect VA800A-SPI to the VM880C module in the correct orientation (pin1 to pin1 aligned).
- Connect USB cable from the VA800A-SPI to the PC USB host port.
- VA800A-SPI will supply power to VM880C after MPSSE driver is properly loaded and the USB host completed USB device configuration.

Hardware Setup MPSSE Cable

- Solder a 10-position single row pin header to J5 footprint of the VM880C board.
- Connect MPSSE leads to VM880C board's J5 (SPI interface) in accordance with Table 5-2
- Plug MPSSE cable to PC USB host port

Software Setup

- Download PC based MPSSE software libraries. MPSSE cable and driver information can be found at <http://www.ftdichip.com/Products/Cables/USBMPSSSE.htm>.
- Launch the Sample Application based on MPSSE from the PC
- For more information on utilizing the VM880C development system with the MPSSE cable and Sample Application, refer to <https://github.com/Bridgetek/EveApps/>. Note that the procedure is the same as for previous generation VM810C modules.

The [FT81x BT88x Programming Guide](#) describes the programming code and formats used by the BT880. The Sample Application is a well-formatted and documented program that illustrates the Programming Guide and provides numerous design examples and reference code demonstrations.

J5 Pin number	J5 Signal	MPSSE pin number	MPSSE Signal	MPSSE Lead Color
1	SCK	2	SK	ORANGE
2	MOSI	3	DO	YELLOW
3	MISO	4	DI	GREEN
4	CS#	5	CS	BROWN
5	INT#	7	GPIOL1	PURPLE
6	PD#	9	GPIOL3	BLUE
7	5V	1	VCC	RED
8	3.3V	-	-	-
9	GND	10	GND	Black
10	GND	-	-	-

Table 5-2 – MPSSE cable connection

7 Contact Information

Head Quarters – Singapore

Bridgetek Pte Ltd
178 Paya Lebar Road, #07-03
Singapore 409030
Tel: +65 6547 4827
Fax: +65 6841 6071

E-mail (Sales) sales.apac@brtchip.com
E-mail (Support) support.apac@brtchip.com

Branch Office – Taipei, Taiwan

Bridgetek Pte Ltd, Taiwan Branch
2 Floor, No. 516, Sec. 1, Nei Hu Road, Nei Hu District
Taipei 114
Taiwan, R.O.C.
Tel: +886 (2) 8797 5691
Fax: +886 (2) 8751 9737

E-mail (Sales) sales.apac@brtchip.com
E-mail (Support) support.apac@brtchip.com

Branch Office - Glasgow, United Kingdom

Bridgetek Pte. Ltd.
Unit 1, 2 Seaward Place, Centurion Business Park
Glasgow G41 1HH
United Kingdom
Tel: +44 (0) 141 429 2777
Fax: +44 (0) 141 429 2758

E-mail (Sales) sales.emea@brtchip.com
E-mail (Support) support.emea@brtchip.com

Branch Office – Vietnam

Bridgetek VietNam Company Limited
Lutaco Tower Building, 5th Floor, 173A Nguyen Van
Troï,
Ward 11, Phu Nhuan District,
Ho Chi Minh City, Vietnam
Tel: 08 38453222
Fax: 08 38455222

E-mail (Sales) sales.apac@brtchip.com
E-mail (Support) support.apac@brtchip.com

Web Site

<http://brtchip.com/>

Distributor and Sales Representatives

Please visit the Sales Network page of the [Bridgetek Web site](#) for the contact details of our distributor(s) and sales representative(s) in your country.

System and equipment manufacturers and designers are responsible to ensure that their systems, and any Bridgetek Pte Ltd (Bridgetek) devices incorporated in their systems, meet all applicable safety, regulatory and system-level performance requirements. All application-related information in this document (including application descriptions, suggested Bridgetek devices and other materials) is provided for reference only. While Bridgetek has taken care to assure it is accurate, this information is subject to customer confirmation, and Bridgetek disclaims all liability for system designs and for any applications assistance provided by Bridgetek. Use of Bridgetek devices in life support and/or safety applications is entirely at the user's risk, and the user agrees to defend, indemnify and hold harmless Bridgetek from any and all damages, claims, suits or expense resulting from such use. This document is subject to change without notice. No freedom to use patents or other intellectual property rights is implied by the publication of this document. Neither the whole nor any part of the information contained in, or the product described in this document, may be adapted or reproduced in any material or electronic form without the prior written consent of the copyright holder. Bridgetek Pte Ltd, Unit 1, 2 Seaward Place, Centurion Business Park, Glasgow G41 1HH, United Kingdom. Scotland Registered Company Number: SC136640

Appendix A – References

Document References

BT880 datasheet: [DS_BT88x](#)

BT880 programming guide: [BRT_AN_088_FT81x_BT88x Programming Guide](#)

Acronyms and Abbreviations

Terms	Description
EVE	Embedded Video Engine
IC	Integrated Circuit
LCD	Liquid Crystal Display
LED	Light Emitting Diode
MPSSE	Multi-Purpose Synchronous Serial Engine
OVP	Over Voltage Protection
PC	Personal Computer
SPI	Serial Peripheral Interface
TFT	Thin Film Transistor
USB	Universal Serial Bus
WQVGA	Wide Quarter Video Graphics Array

Appendix B - List of Figures and Tables

List of Figures

Figure 3-1 – VM880C board top view.....	4
Figure 3-2 – VM880C board top layer	5
Figure 3-3 – VM880C board bottom layer.....	5
Figure 4-1 - BT880 and LCD circuit	9
Figure 4-2 – SPI Interface Circuit.....	10
Figure 4-3 – Audio Circuit	10
Figure 5-1 – VM880C connects to PC via VA800A-SPI or MPSSE cable	12
Figure 6-1 – PCB mechanical dimensions	14

List of Tables

Table 2-1 – Ordering information	2
Table 3-1 – CN1 Pinout.....	6
Table 3-2 – CN2 Pinout.....	6
Table 3-3 – J1 Pinout	7
Table 3-4 – J2 Pin Options	7
Table 3-5 – J5 Pinout	7
Table 3-6 – JP1 Pin options	7
Table 3-7 – JP1 Pin options	8
Table 5-1 – Board power configuration	11
Table 5-2 – MPSSE cable connection	13