

**Precision Voltage Reference**



**FEATURES**

- Very High Accuracy:  $\pm 10V$  Output,  $\pm 1.0mV$
- Extremely Low Drift:  $1.09ppm/^{\circ}C$  ( $-55^{\circ}C$  to  $+125^{\circ}C$ )
- Low Warm-up Drift:  $1.0ppm$  Typical
- Excellent Stability:  $6ppm/1000$  Hrs. Typical
- Excellent Line Regulation:  $3ppm/V$  Typical
- Hermetic 14-pin Ceramic DIP
- Military Processing Option



**APPLICATIONS**

- Precision A/D and D/A Converters
- Transducer Excitation
- Accurate Comparator Threshold Reference
- High Resolution Servo Systems
- Digital Voltmeters
- High Precision Test and Measurement Instruments

**DESCRIPTION**

VRE102 Precision Voltage Reference provides ultrastable  $\pm 10V$  outputs with  $\pm 1.0mV$  initial accuracy and temperature coefficient as low as  $1.09ppm/^{\circ}C$  over the full military temperature range. This improvement in accuracy is made possible by a unique, proprietary multipoint laser compensation technique.

Significant improvements have been made in other performance parameters as well, including initial accuracy, warm-up drift, line regulation, and long-term stability, making the VRE102 the most accurate and stable  $10V$  reference available.

VRE100/102 devices are available in two operating temperature ranges,  $-25^{\circ}C$  to  $+85^{\circ}C$  and  $-55^{\circ}C$  to  $+125^{\circ}C$ , and two performance grades. All devices are packaged in 14-pin hermetic ceramic packages for maximum long-term stability. “M” versions are screened for high reliability and quality.

Superior stability, accuracy, and quality make this reference ideal for precision applications such as A/D and D/A converters, high-accuracy test and measurement instrumentation, and transducer excitation.

**SELECTION GUIDE**

Model	Output (V)	Temperature Operating Range	Volt Deviation (Max)
VRE102C	$\pm 10$	$-25^{\circ}C$ to $+85^{\circ}C$	$\pm 0.8mV$
VRE102CA	$\pm 10$	$-25^{\circ}C$ to $+85^{\circ}C$	$\pm 0.6mV$
VRE102M	$\pm 10$	$-55^{\circ}C$ to $+125^{\circ}C$	$\pm 1.2mV$

## TYPICAL CONNECTION

Figure 1: Typical Connection

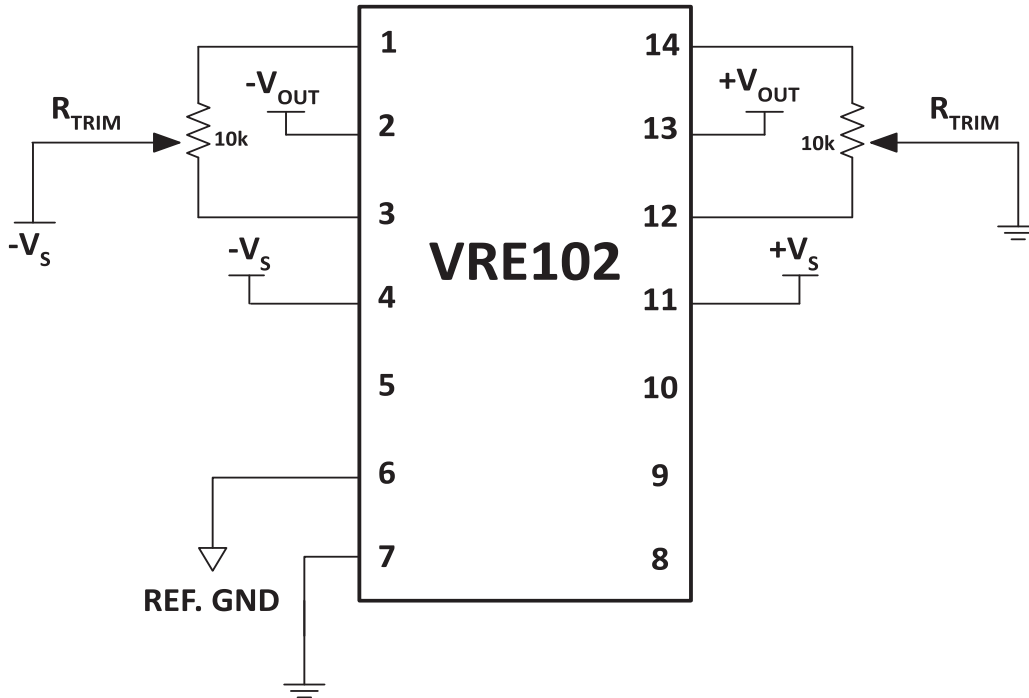

### PIN DESCRIPTIONS

Pin Number	Name	Description
1, 3	-ADJ	Optional fine adjustment for approximately $\pm 20\text{mV}$ on -OUT.
2	-OUT	-10V output.
4	$-V_S$	The negative supply voltage connection.
6	REF_GND	Provided for accurate ground sensing. Internally connected to GND.
7	GND	Ground.
11	$+V_S$	The positive supply voltage connection.
12, 14	+ADJ	Optional fine adjustment for approximately $\pm 20\text{mV}$ on +OUT.
13	+OUT	+10V output.
5, 8, 9, 10	NC	No connection.

## SPECIFICATIONS

$V_{PS} = \pm 15V$ ,  $T = 25^{\circ}C$ ,  $R_L = 10k\Omega$  unless otherwise noted.

### ABSOLUTE MAXIMUM RATINGS

Parameter	C			CA			M			Units
	Min	Typ	Max	Min	Typ	Max	Min	Typ	Max	
Power Supply	$\pm 13.5$		$\pm 22$	*		*	*		*	V
Operating Temperature	-25		+85	*		*	-55		+125	$^{\circ}C$
Storage Temperature	-65		+150	*		*	*		*	$^{\circ}C$
Short Circuit Protection	Continuous			*			*			
Soldering Temperature (10 sec max)			+260			*			*	$^{\circ}C$

### ELECTRICAL SPECIFICATIONS

Parameter	C			CA			M			Units
	Min	Typ	Max	Min	Typ	Max	Min	Typ	Max	
Output Voltage		$\pm 10$			*			*		V
Initial Error			$\pm 1.2$			$\pm 1.0$			$\pm 1.7$	mV
Warmup Drift		2			1			2		ppm
$T_{MIN} - T_{MAX}^1$			0.8			0.6			1.2	mV
Long-Term Stability		6			*			*		ppm/ 1000 hrs
Noise (0.1 - 10Hz)		6			*			*		$\mu V_{pp}$
Output Current	$\pm 10$			*			*			mA
Line Regulation		3	10		*	*		*	*	ppm/V
Load Regulation		3			*			*		ppm/ mA
Output Adjustment		20			*			*		mV
Temperature Coefficient		4			*			*		$\mu V/^{\circ}C/mV$
Power Supply Current, VRE102 +PS <sup>2</sup>		7	9		*	*		*	*	mA
Power Supply Current, VRE102 -PS <sup>2</sup>		4	6		*	*		*	*	mA

- Using the Box Method, the specified value is the maximum deviation from the output voltage at  $25^{\circ}C$  over the specified operating temperature range.
- The specified values are unloaded.

**Note:** \* Same as C Model.

TYPICAL PERFORMANCE GRAPHS

Figure 2:  $V_{OUT}$  vs. Temperature (VRE102C)

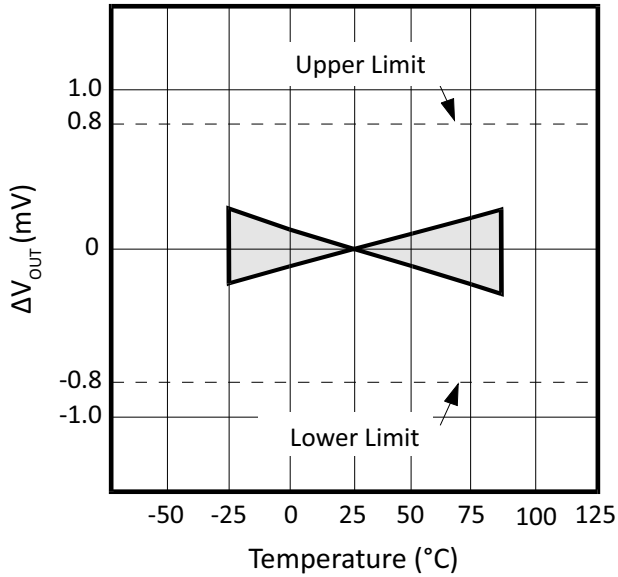

Figure 3:  $V_{OUT}$  vs. Temperature (VRE102CA)

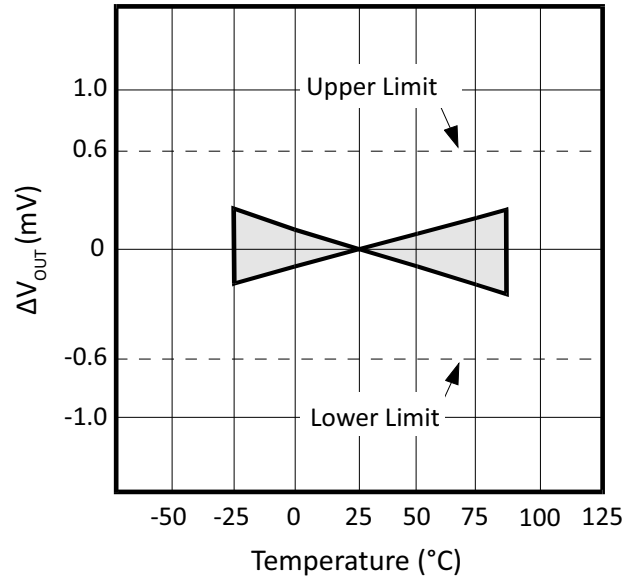
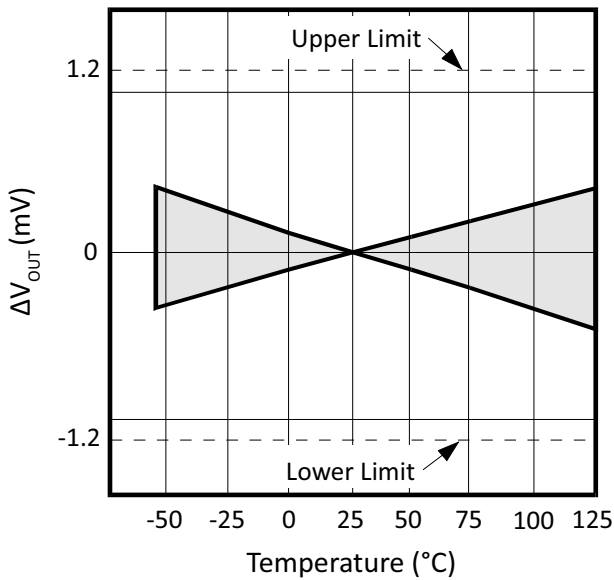
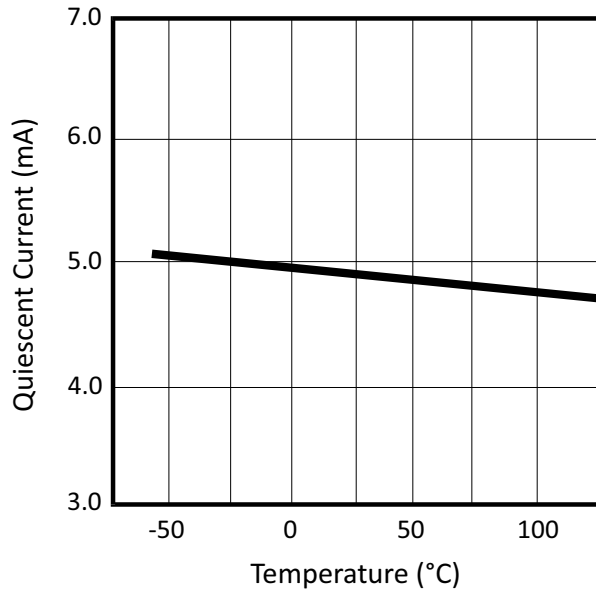

Figure 4:  $V_{OUT}$  vs. Temperature (VRE102M)



VRE102 POSITIVE OUTPUT

**Figure 5: Quiescent Current vs. Temperature**



**Figure 6: Junction Temp. Rise vs. Output Current**

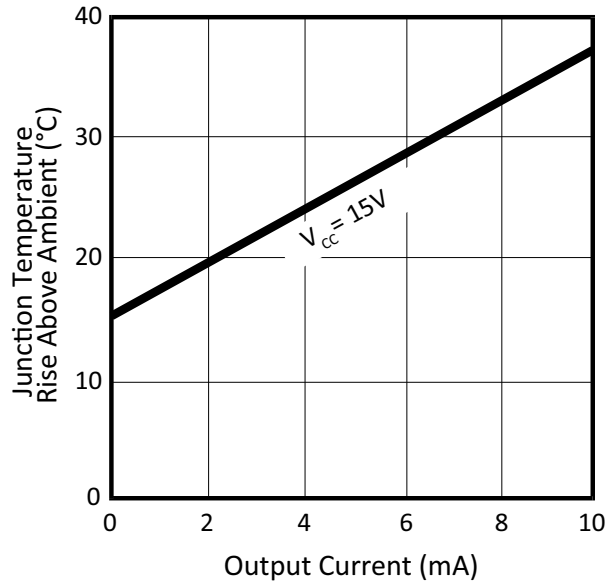

**Figure 7: PSRR vs. Frequency**

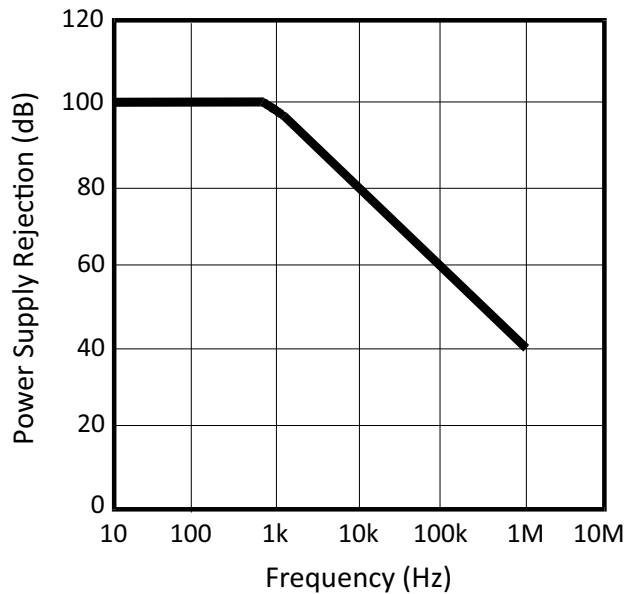

VRE102 NEGATIVE OUTPUT

Figure 8: Quiescent Current vs. Temperature

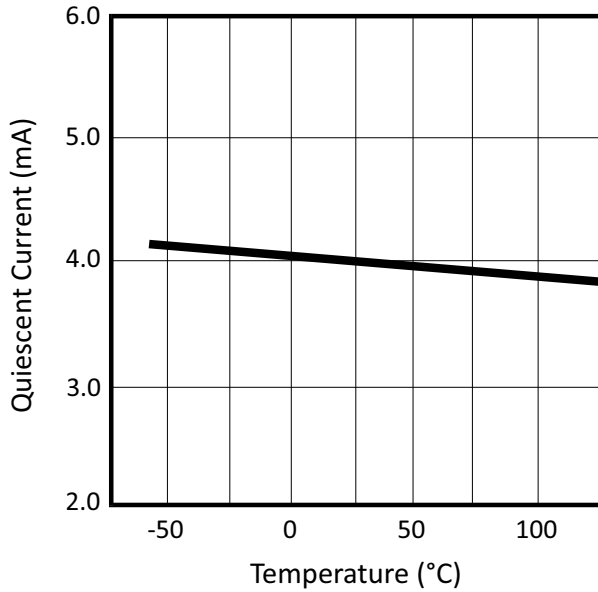

Figure 9: Junction Temp. Rise vs. Output Current

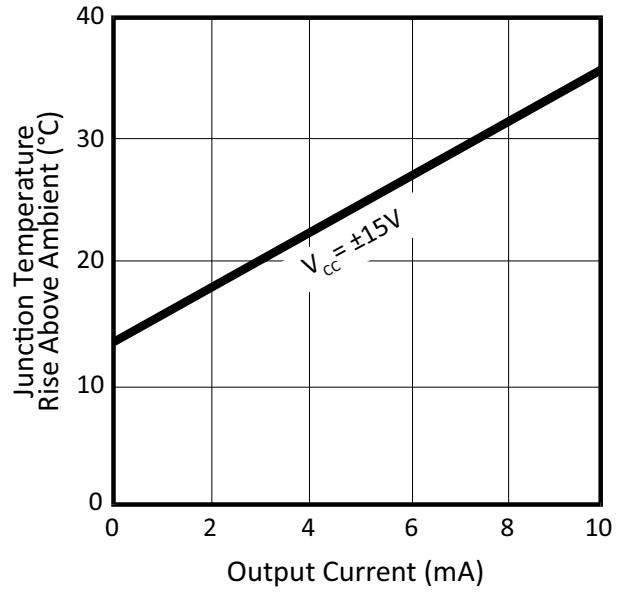
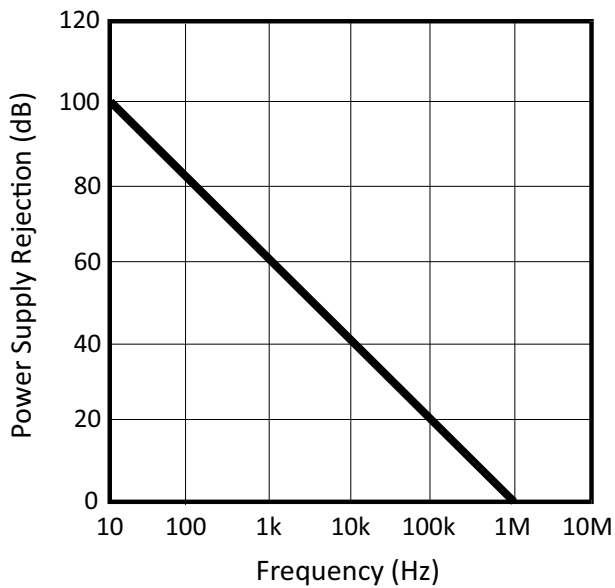
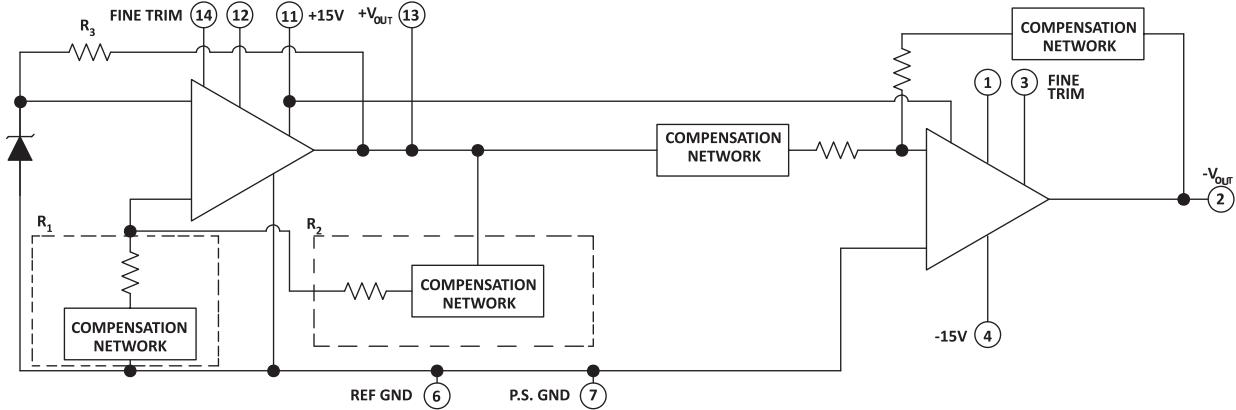

Figure 10: PSRR vs. Frequency



## BLOCK DIAGRAM

Figure 11: Block Diagram



## THEORY OF OPERATION

The following discussion refers to the block diagram in Figure 11. In operation, approximately 6.3V is applied to the noninverting input of the op amp. The voltage is amplified by the op amp to produce a 10V output. The gain is determined by the networks R1 and R2:  $G=1 + R2/R1$ . The 6.3V Zener diode is used because it is the most stable diode over time and temperature.

The Zener operating current is derived from the regulated output voltage through R3. This feedback arrangement provides a closely regulated Zener current. This current determines the slope of the references' voltage vs. temperature function. By trimming the Zener current a lower drift over temperature can be achieved. But since the voltage vs. temperature function is nonlinear this compensation technique is not well suited for wide temperature ranges.

A nonlinear compensation network of thermistors and resistors is used in the VRE series voltage references. This proprietary network eliminates most of the nonlinearity in the voltage vs. temperature function. By then adjusting the slope, this series produces a very stable voltage over wide temperature ranges. This network is less than 2% of the overall network resistance so it has a negligible effect on long term stability. By using highly stable resistors in our network, we produce a voltage reference that also has very good long term stability.

## APPLICATION INFORMATION

Page 2 shows the typical connection of the VRE102 voltage reference with the optional trim resistors. When trimming the VRE102, the positive voltage should be trimmed first since the negative voltage tracks the positive side. Pay careful attention to the circuit layout to avoid noise pickup and voltage drops in the lines.

The VRE102 voltage reference has the ground terminal brought out on two pins (pin 6 and pin 7) which are connected together internally. This allows the user to achieve greater accuracy when using a socket. Voltage references have a voltage drop across their power supply ground pin due to quiescent current flowing through the contact resistance. If the contact resistance was constant with time and temperature, this voltage drop could be trimmed out. When the reference is plugged into a socket, this source of error can be as high as 20ppm. By connecting pin 7 to the power supply ground and pin 6 to a high impedance ground point in the measurement circuit, the error due to the contact resistance can be eliminated. If the unit is soldered into place the contact resistance is sufficiently small that it doesn't affect performance. The VRE series voltage references can be connected with or without the use of pin 6 and still provide superior performance.

## PIN CONFIGURATION

Figure 12: Pin Configuration

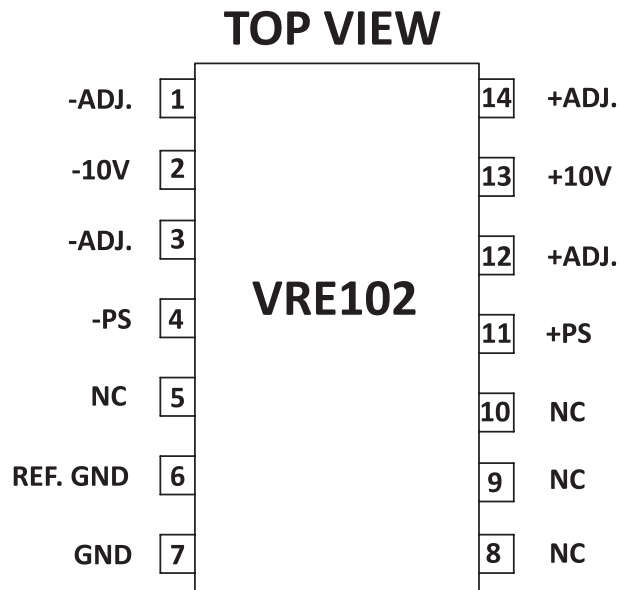



**PACKAGE OPTIONS**

Part Number	Apex Package Style	Description
VRE102C	HC	Hermetic 14-pin Ceramic DIP
VRE102CA	HC	Hermetic 14-pin Ceramic DIP
VRE102M	HC	Hermetic 14-pin Ceramic DIP

**PACKAGE STYLE HC**

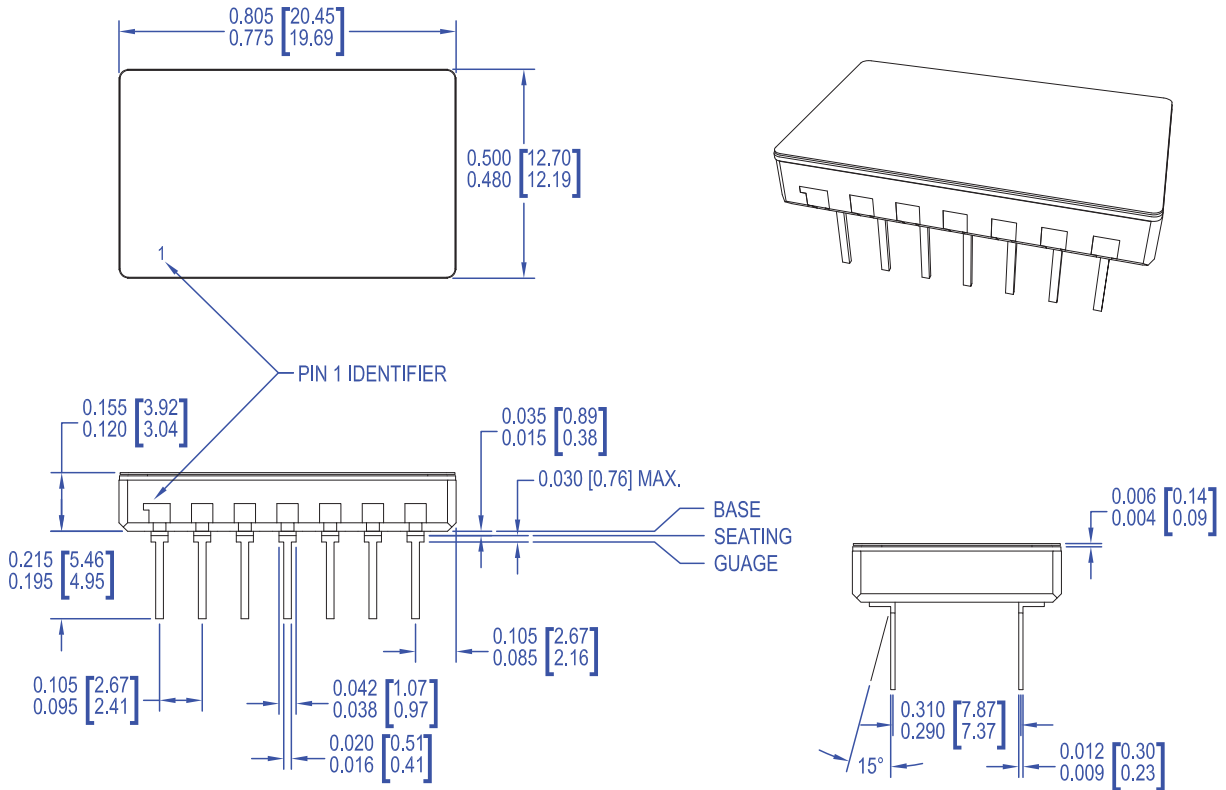

**NOTES:**

1. Dimensions are inches & [millimeters].
2. Bracketed alternate units are for reference only.
3. Pins: Phosphor bronze, Gold over Nickel plated.
4. Material: Alumina Ceramic substrate and cover.
5. Cover: Electroless Nickel plated.
6. Package weight: 0.092 oz. [2.605 g].