

## Precision Voltage Reference

### FEATURES

- ◆ Very High Accuracy: +4.5 V Output,  $\pm 0.8$  mV
- ◆ Extremely Low Drift: 1.48 ppm/ $^{\circ}\text{C}$  ( $-55^{\circ}\text{C}$  to  $+125^{\circ}\text{C}$ )
- ◆ Excellent Stability: 6 ppm/1000 Hrs. Typical
- ◆ Excellent Line Regulation: 6 ppm/V Typical
- ◆ Wide Supply Range: +13.5 V to +22.0 V
- ◆ Hermetic 20-terminal Ceramic LCC
- ◆ Military Processing Available

### APPLICATIONS

- ◆ Precision A/D and D/A Converters
- ◆ Transducer Excitation
- ◆ Accurate Comparator Threshold Reference
- ◆ High Resolution Servo Systems
- ◆ Digital Voltmeters
- ◆ High Precision Test and Measurement Instruments

### DESCRIPTION

VRE204 Series Precision Voltage References provide ultrastable +4.5 V outputs with up to  $\pm 0.8$  mV initial accuracy and temperature coefficient as low as 1.48 ppm/ $^{\circ}\text{C}$  over the full military temperature range.

These references are specifically designed to be used with successive-approximation type Analog-to-Digital Converters (ADCs). Specify an ADC with exceptional temperature drift, which can only be as good as the external reference used. The VRE204 combined with the right ADC will provide the lowest drift data conversion obtainable.

The VRE204 series is available in the military operating temperature range  $-55^{\circ}\text{C}$  to  $+125^{\circ}\text{C}$ , and two performance grades. All devices are packaged in 20-terminal LCC ceramic packages for maximum long-term stability. These "M" versions are screened for high reliability and quality.

Superior stability, accuracy, and quality make the VRE204 ideal for all precision applications which may require a 4.5 V reference. High-accuracy test and measurement instrumentation, and transducer excitation are some other applications which can benefit from the high accuracy of the VRE204.

**Figure 1. BLOCK DIAGRAM**

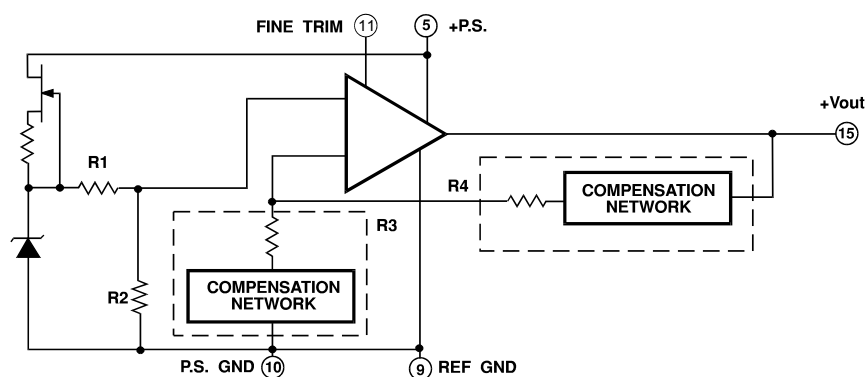

### SELECTION GUIDE

Model	Output (V)	Temperature Operating Range	Volt Deviation (MAX)
VRE204M	+4.5V	$-55^{\circ}\text{C}$ to $+125^{\circ}\text{C}$	$\pm 0.69\text{mV}$
VRE204MA	+4.5V	$-55^{\circ}\text{C}$ to $+125^{\circ}\text{C}$	$\pm 0.60\text{mV}$



**20-terminal Ceramic LCC  
Package Style HD**

## 1. CHARACTERISTICS AND SPECIFICATIONS

### ELECTRICAL SPECIFICATIONS

$V_{PS} = +15V$ ,  $T = +25^{\circ}C$ ,  $R_L = 10K \Omega$  UNLESS OTHERWISE NOTED.

Model	M			MA			Units
	Min	Typ	Max	Min	Typ	Max	
<b>ABSOLUTE MAXIMUM RATINGS</b>							
Power Supply	+13.5		+22	*		*	V
Operating Temperature	-55		+125	*		*	$^{\circ}C$
Storage Temperature	-65		+150	*		*	$^{\circ}C$
Short Circuit Protection	Continuous			*			
<b>OUTPUT VOLTAGE</b>							
VRE204		+4.5			*		V
<b>OUTPUT VOLTAGE ERRORS</b>							
Initial Error			$\pm 890$			$\pm 800$	$\mu V$
Warmup Drift		2			1		ppm
$T_{MIN} - T_{MAX}$ (Note1)			690			600	$\mu V$
Long-Term Stability		6			*		ppm/1000hrs.
Noise (0.1 - 10Hz)		3			*		$\mu V_{pp}$
<b>OUTPUT CURRENT</b>							
Range	$\pm 10$			*			mA
<b>REGULATION</b>							
Line		6	10		*	*	ppm/V
Load		3			*		ppm/mA
<b>OUTPUT ADJUSTMENT</b>							
Range		10			*		mV
Temperature Coefficient		4			*		$\mu V/^{\circ}C/mV$
<b>POWER SUPPLY CURRENT</b> (Note 2)							
VRE204 +PS		5	7		*	*	mA

#### NOTES:

- \* Same as M Models.
- 1. Using the box method, the specified value is the maximum deviation from the output voltage at  $25^{\circ}C$  over the specified operating temperature range.
- 2. The specified values are unloaded.

## 2. TYPICAL PERFORMANCE GRAPHS

V<sub>OUT</sub> vs. TEMPERATURE

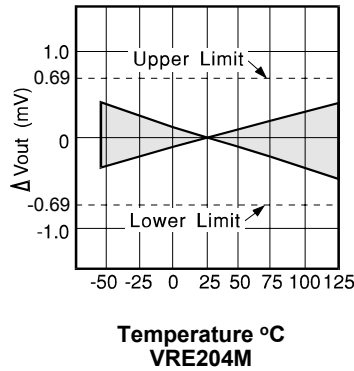

V<sub>OUT</sub> vs. TEMPERATURE

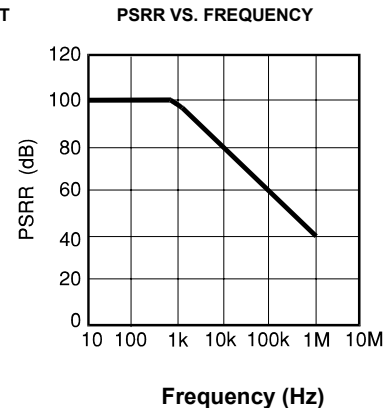
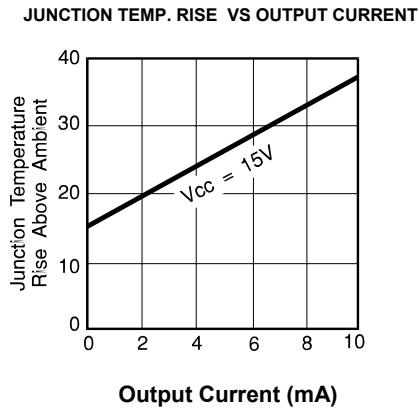
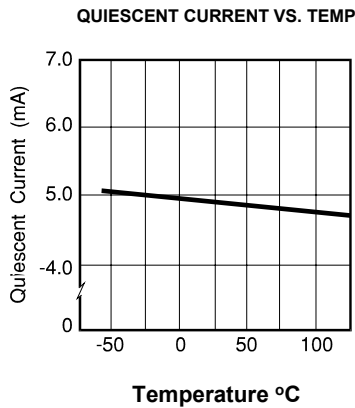
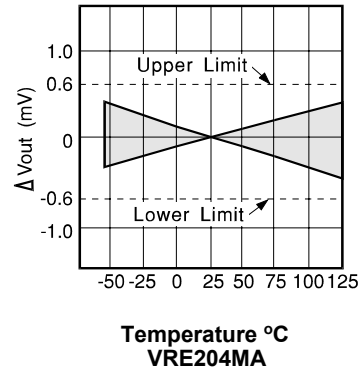

## 3. THEORY OF OPERATION

The following discussion refers to the block diagram in Figure 1. A FET current source is used to bias a 6.3 zener diode. The zener voltage is divided by the resistor network R1 and R2. This voltage is then applied to the noninverting input of the operational amplifier which amplifies the voltage to produce a 4.5 V output. The gain is determined by the resistor networks R3 and R4:  $G=1 + R4/R3$ . The 6.3 zener diode is used because it is the most stable diode over time and temperature.

The current source provides a closely regulated zener current, which determines the slope of the references' voltage vs. temperature function. By trimming the zener current a lower drift over temperature can be achieved. But since the voltage vs. temperature function is nonlinear this compensation technique is not well suited for wide temperature ranges.

A nonlinear compensation network of thermistors and resistors is used in the VRE series voltage references. This proprietary network eliminates most of the nonlinearity in the voltage vs. temperature function. By then adjusting the slope, the VRE204 series produces a very stable voltage over wide temperature ranges. This network is less than 2% of the overall network resistance so it has a negligible effect on long term stability. By using highly stable resistors in our network, we produce a voltage reference that also has very good long term stability.