

Precision Voltage Reference

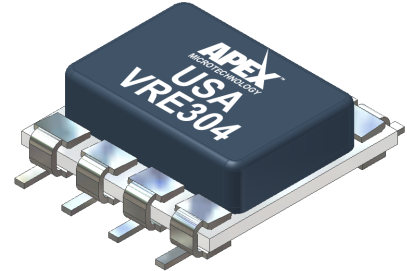

FEATURES

- +4.5V Output, $\pm 0.90\text{mV}$ (.02%)
- Temperature Drift: $2.0\text{ppm}/^\circ\text{C}$
- Low Noise: $3\mu\text{V}_{\text{p-p}}$ (0.1-10 Hz)
- Industry Standard Pinout: 8-Pin Surface Mount Package
- Excellent Line Regulation: $6\text{ppm}/\text{V}$ Typical
- Output Trim Capability



APPLICATIONS

The VRE304 is recommended for use as a reference for 14, 16, or 18 bit D/A converters which require an external precision reference. The device is also ideal for calibrating scale factor on high resolution A/D converters. The VRE304 offers superior performance over monolithic references.

DESCRIPTION

The VRE304 is a low cost, high precision +4.5V reference. Available in an industry standard 8-pin surface mount package, the device is ideal for upgrading systems that use lower performance references.

The device provides ultrastable +4.5V output with $\pm 0.90\text{mV}$ (0.02%) initial accuracy and a temperature coefficient of $2.0\text{ppm}/^\circ\text{C}$. This improvement in accuracy is made possible by a unique, patented multipoint laser compensation technique. Significant improvements have been made in other performance parameters as well, including initial accuracy, warm-up drift, line regulation, and long-term stability.

For enhanced performance, the VRE304 has an external trim option for users who want less than 0.01% initial error. For ultra low noise applications, an external capacitor can be attached between the noise reduction pin and the ground pin. A reference ground pin is provided to eliminate socket contact resistance errors.

SELECTION GUIDE

Model	Initial Error (mV)	Temp. Coeff. (ppm/ $^\circ\text{C}$)	Temp Range ($^\circ\text{C}$)
VRE304CS	± 0.90	2.0	0°C to $+70^\circ\text{C}$

TYPICAL CONNECTION

Figure 1: Typical Connection

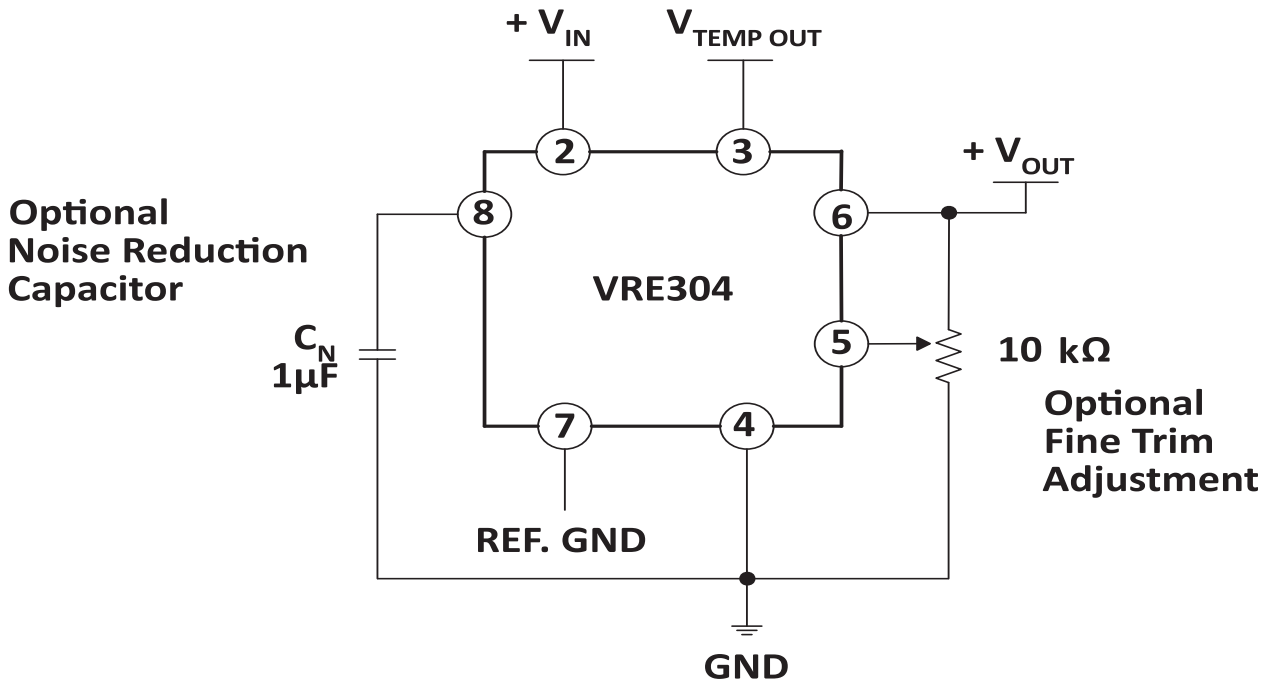

PIN DESCRIPTIONS

Pin Number	Name	Description
1	NC	No connection.
2	V_{IN}	The supply voltage connection.
3	TEMP	Provides voltage proportional to package temperature for monitoring purposes.
4	GND	Ground.
5	TRIM	Optional fine adjustment. Connect to a voltage divider between OUT and GND.
6	OUT	4.5V output.
7	REF_GND	Provided for accurate ground sensing. Internally connected to GND.
8	NOISE	Optional noise reduction. Connect a μF capacitor between this pin and GND.

SPECIFICATIONS

$V_{IN} = +15V$, $T = +25^{\circ}C$, $R_L = 10\text{ k}\Omega$ unless otherwise noted.

ABSOLUTE MAXIMUM RATINGS

Parameter	Min	Typ	Max	Units
Power Supply	+13.5	+15	+22	V
Operating Temperature	0		+70	$^{\circ}C$
Storage Temperature	-65		+150	$^{\circ}C$
Short Circuit Protection	Continuous			
Soldering Temperature (10 sec max)			+260	$^{\circ}C$

ELECTRICAL SPECIFICATIONS

Parameter	Min	Typ	Max	Units
Output Voltage ¹		+4.5		V
Temp. Sensor Voltage		630		mV
Initial Error ²			± 0.90	mV
Warmup Drift		3		ppm
$T_{MIN} - T_{MAX}$ ³			2.0	ppm/ $^{\circ}C$
Long-Term Stability		6		ppm/1000h
Noise (0.1 - 10 Hz) ⁴		3		μV_{pp}
Output Current	± 10			mA
Line Regulation		6	10	ppm/V
Load Regulation		3		ppm/mA
Output Adjustment		10		mV
Power Supply Current, +PS ⁵		5	7	mA

1. The temperature coefficient is $-2.1\text{mV}/^{\circ}C$.
2. The specified values are without external trim.
3. The temperature coefficient (TC) is determined by the box method using the following formula:

$$TC = \frac{V_{MAX} - V_{MIN}}{V_{NOMINAL} \times (T_{MAX} - T_{MIN})} \times 10^6$$

4. The specified values are without the external noise reduction capacitor.
5. The specified values are unloaded.

TYPICAL PERFORMANCE GRAPHS

Figure 2: V_{OUT} vs. Temperature

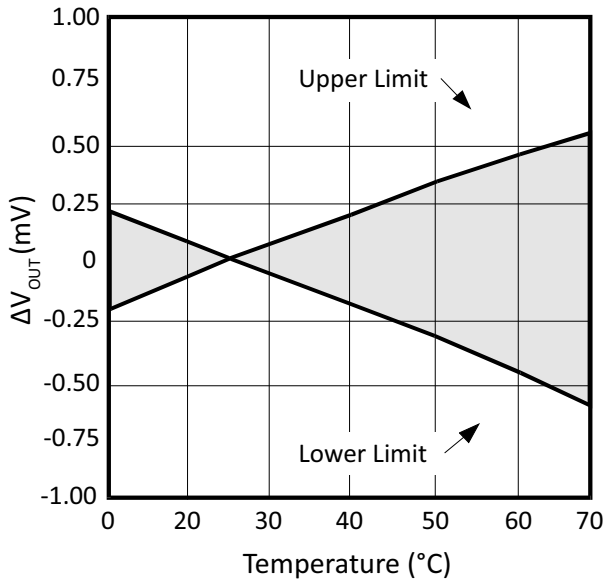

Figure 3: Power Supply Current vs. Temp.

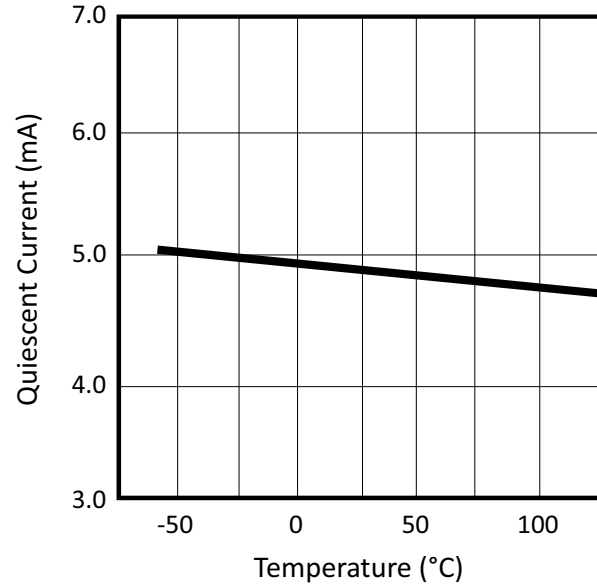

Figure 4: Junction Temp Rise vs. Output Current

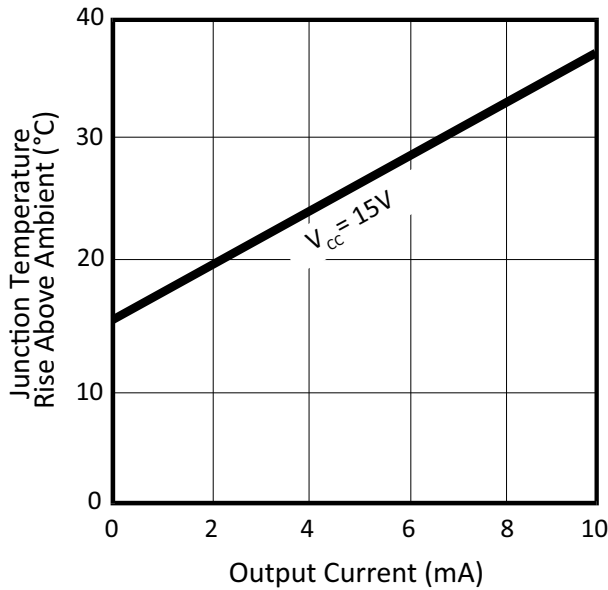
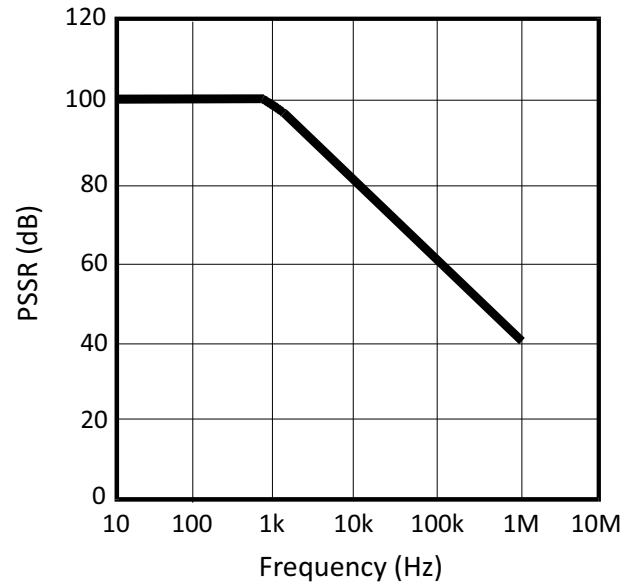
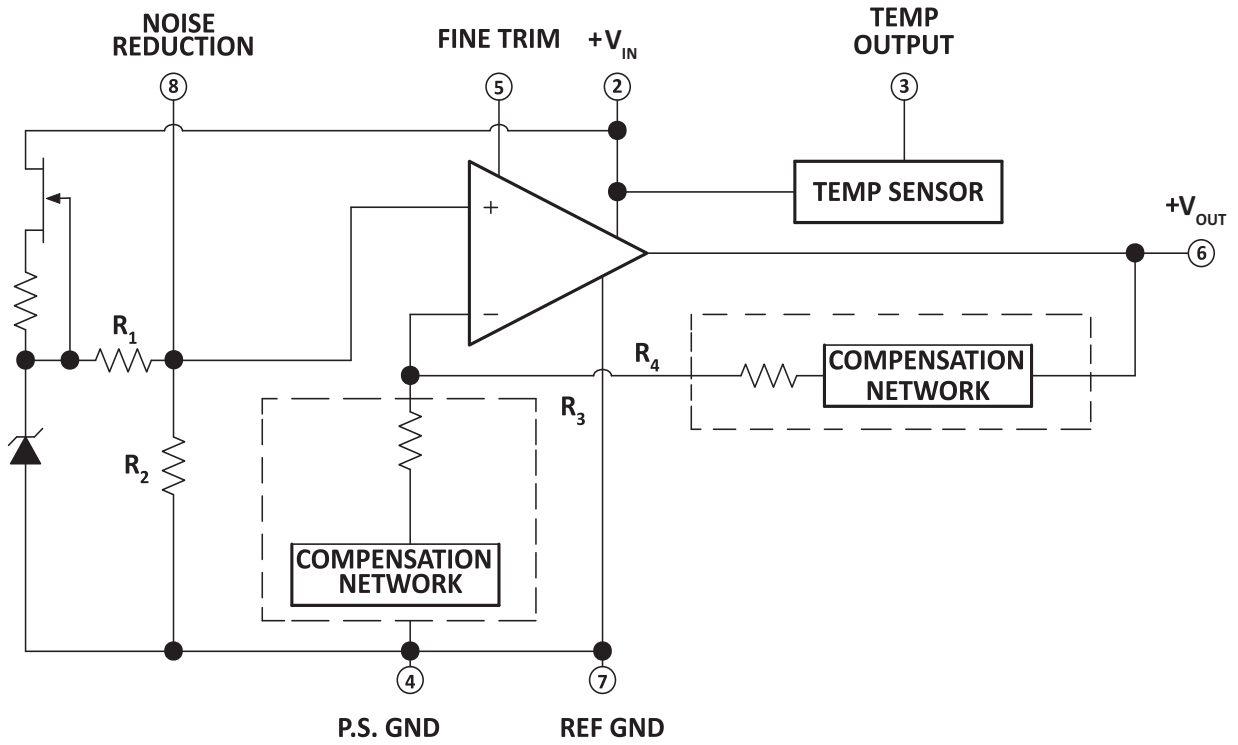

Figure 5: PSRR vs. Frequency



BLOCK DIAGRAM

Figure 6: Block Diagram



THEORY OF OPERATION

The following discussion refers to the block diagram in Figure 6. A FET current source is used to bias a 6.3V Zener diode. The Zener voltage is divided by the resistor network R1 and R2. This voltage is then applied to the noninverting input of the operational amplifier which amplifies the voltage to produce a 4.5V output. The gain is determined by the resistor networks R3 and R4: $G=1 + R4/R3$. The 6.3V Zener diode is used because it is the most stable diode over time and temperature.

The current source provides a closely regulated Zener current, which determines the slope of the references' voltage vs. temperature function. By trimming the Zener current a lower drift over temperature can be achieved. But since the voltage vs. temperature function is nonlinear this compensation technique is not well suited for wide temperature ranges.

A nonlinear compensation network of thermistors and resistors is used in the VRE series voltage references. This proprietary network eliminates most of the nonlinearity in the voltage vs. temperature function. By adjusting the slope, a very stable voltage is produced over wide temperature ranges.

This network is less than 2% of the overall network resistance so it has a negligible effect on long term stability.

The proper connection of the VRE304 series voltage references with the optional trim resistor for initial error and the optional capacitor for noise reduction is shown in Figure 1. The VRE304 reference has the ground terminal brought out on two pins (pin 4 and pin 7) which are connected together internally. This allows the user to achieve greater accuracy when using a socket. Voltage references have a voltage drop across their power supply ground pin due to quiescent current flowing through the contact resistance. If the contact resistance was constant with time and temperature, this voltage drop could be trimmed out. When the reference is plugged into a socket, this source of error can be as high as 20ppm. By connecting pin 4 to the power supply ground and pin 7 to a high impedance ground point in the measurement circuit, the error due to the contact resistance can be eliminated. If the unit is soldered into place, the contact resistance is sufficiently small that it does not effect performance. Pay careful attention to the circuit layout to avoid noise pickup and voltage drops in the lines.

PIN CONFIGURATION

Figure 7: Pin Configuration

