

Precision Voltage Reference

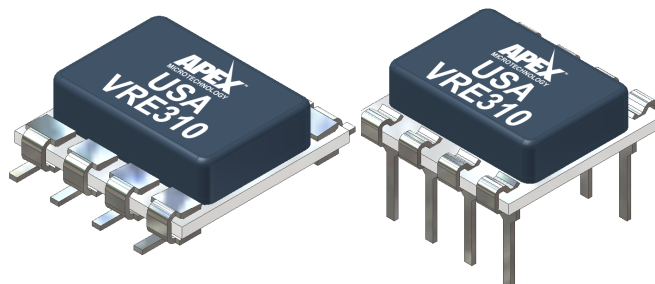

FEATURES

- +10V Output, $\pm 1.0\text{mV}$ (0.01%)
- Temperature Drift: 0.6 ppm/ $^{\circ}\text{C}$
- Low Noise: $6\mu\text{V}_{\text{p-p}}$ (0.1-10 Hz)
- Industry Standard Pinout: 8-pin DIP or Surface Mount Package
- Excellent Line Regulation: 6ppm/V Typical
- Output Trim Capability



APPLICATIONS

The VRE310 is recommended for use as a reference for 14, 16, or 18-bit D/A converters which require an external precision reference. The device is also ideal for calibrating scale factor on high resolution A/D converters. The VRE310 offers superior performance over monolithic references.

DESCRIPTION

The VRE310 is a low cost, high precision +10V reference. Available in an industry standard 8-pin DIP or SMT, the device is ideal for upgrading systems that use lower performance references.

The device provides ultrastable +10V output with $\pm 1.0\text{mV}$ (0.01%) initial accuracy and a temperature coefficient of 0.6ppm/ $^{\circ}\text{C}$. This improvement in accuracy is made possible by a unique, patented multipoint laser compensation technique. Significant improvements have been made in other performance parameters as well, including initial accuracy, warm-up drift, line regulation, and long-term stability, making the VRE310 series the most accurate reference available in a standard 8-pin DIP or SMT package.

For enhanced performance, the VRE310 has an external trim option for users who want less than 0.01% initial error. For ultra low noise applications, an external capacitor can be attached between the noise reduction pin and the ground pin. A reference ground pin is provided to eliminate socket contact resistance errors.

SELECTION GUIDE

Model	Initial Error (mV)	Temp. Coeff. (ppm/ $^{\circ}\text{C}$)	Temp Range ($^{\circ}\text{C}$)	Package Options
VRE310AS	± 1.0	0.6	0 $^{\circ}\text{C}$ to +70 $^{\circ}\text{C}$	SMT8 (GD)
VRE310AD	± 1.0	0.6	0 $^{\circ}\text{C}$ to +70 $^{\circ}\text{C}$	DIP8 (KD)
VRE310JS	± 1.0	0.6	-40 $^{\circ}\text{C}$ to +85 $^{\circ}\text{C}$	SMT8 (GD)
VRE310JD	± 1.0	0.6	-40 $^{\circ}\text{C}$ to +85 $^{\circ}\text{C}$	DIP8 (KD)

TYPICAL CONNECTION

Figure 1: Typical Connection

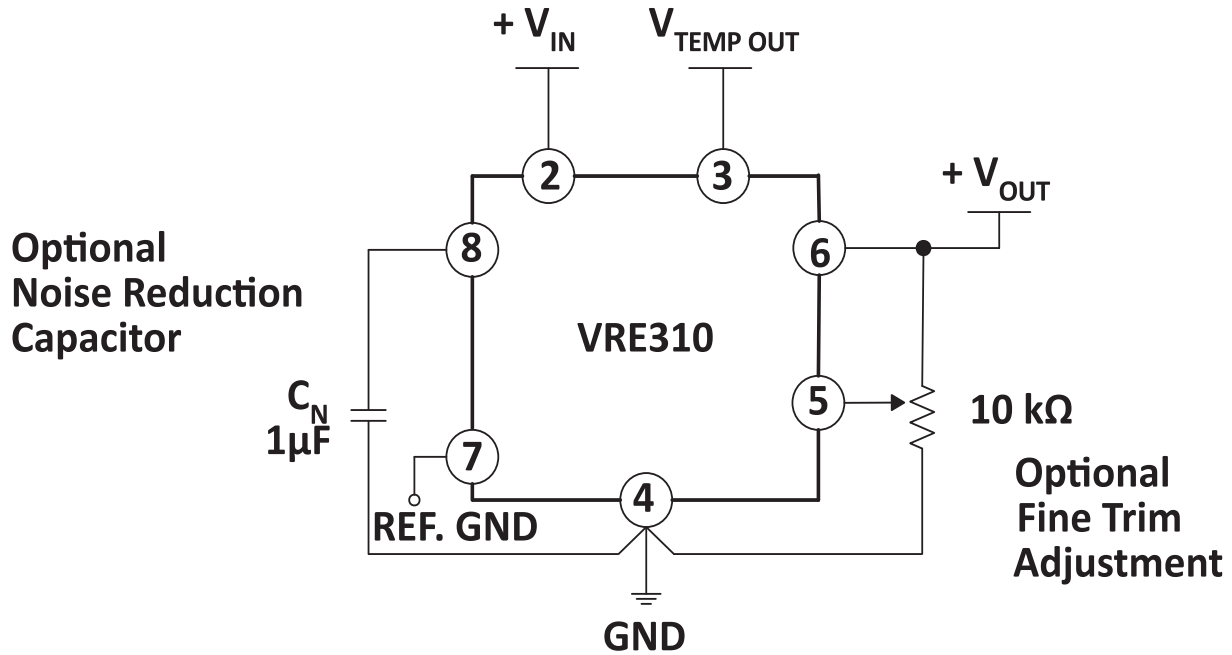

PIN DESCRIPTIONS

Pin Number	Name	Description
1	NC	No connection.
2	V_{IN}	The supply voltage connection.
3	TEMP	Provides voltage proportional to package temperature for monitoring purposes.
4	GND	Ground.
5	TRIM	Optional fine adjustment. Connect to a voltage divider between OUT and GND.
6	OUT	10V output.
7	REF_GND	Provided for accurate ground sensing. Internally connected to GND.
8	NOISE	Optional noise reduction. Connect a μF capacitor between this pin and GND.

SPECIFICATIONS

$V_{IN} = +15V$, $T = +25^{\circ}C$, $R_L = 10\ k\Omega$ Unless Otherwise Noted.

ABSOLUTE MAXIMUM RATINGS

Parameter	Min	Typ	Max	Units
Power Supply	+13.5	+15	+22	V
Operating Temperature (A)	0		+70	$^{\circ}C$
Operating Temperature (J)	-40		+85	$^{\circ}C$
Storage Temperature	-65		+150	$^{\circ}C$
Short Circuit Protection	Continuous			
Soldering Temperature (10 sec max)			+260	$^{\circ}C$

ELECTRICAL SPECIFICATIONS

Parameter	Conditions	Min	Typ	Max	Units
Output Voltage (VRE310)			+10.0		V
Temp. Sensor Voltage ¹			630		mV
Initial Error ²				± 1.0	mV
Warmup Drift			1		ppm
$T_{MIN} - T_{MAX}$ ³				0.6	ppm/ $^{\circ}C$
Long-Term Stability			6		ppm/ 1000hrs.
Noise (0.1 - 10 Hz) ⁴			6		μV_{pp}
Output Current	Range	± 10			mA
Line Regulation			6	10	ppm/V
Load			3		ppm/mA
Output Adjustment	Range		20		mV
Power Supply Current ⁵	VRE310 +PS		6.5	8.5	mA

1. The temp. coefficient is $-2.1\text{mV}/^{\circ}C$.
2. The specified values are without external trim.
3. The temperature coefficient is determined by the box method using the following formula:

$$TC = \frac{V_{MAX} - V_{MIN}}{V_{NOMINAL} \times (T_{MAX} - T_{MIN})} \times 10^6$$

4. The specified values are without the external noise reduction capacitor.
5. The specified values are unloaded.

TYPICAL PERFORMANCE GRAPHS

Figure 2: V_{OUT} vs. Temperature (VRE310A)

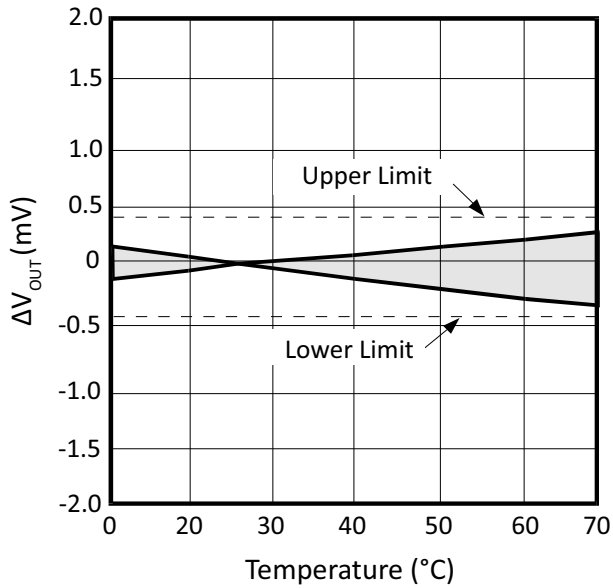

Figure 3: V_{OUT} vs. Temperature (VRE310J)

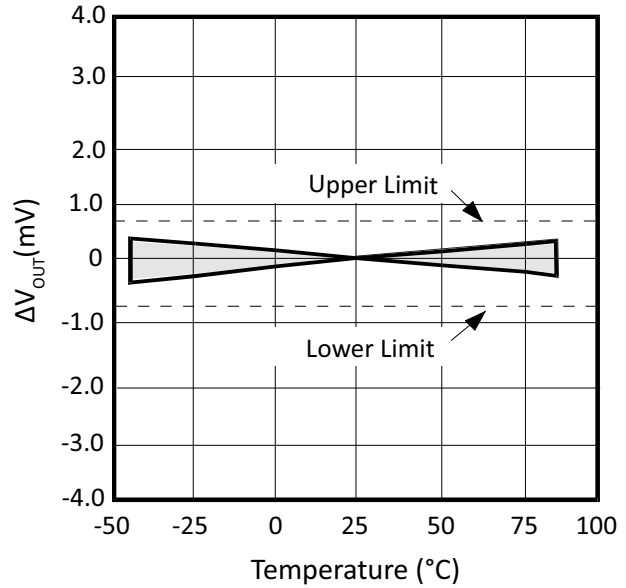

Figure 4: Quiescent Current vs. Temperature

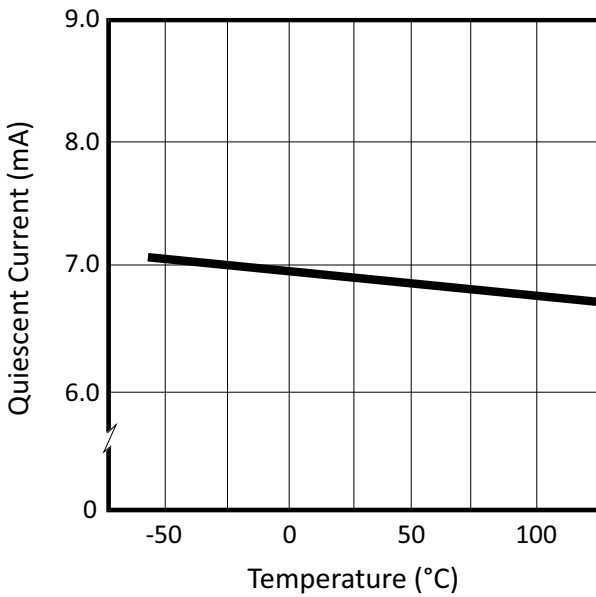

Figure 5: Junction Temp. Rise vs. Output Current

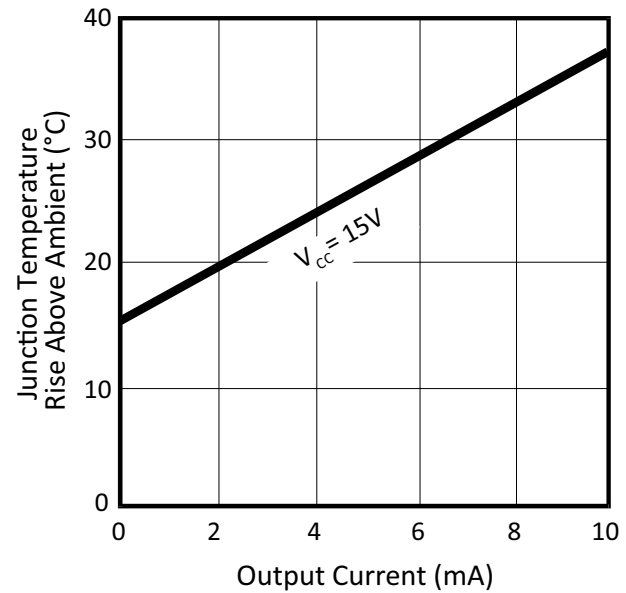
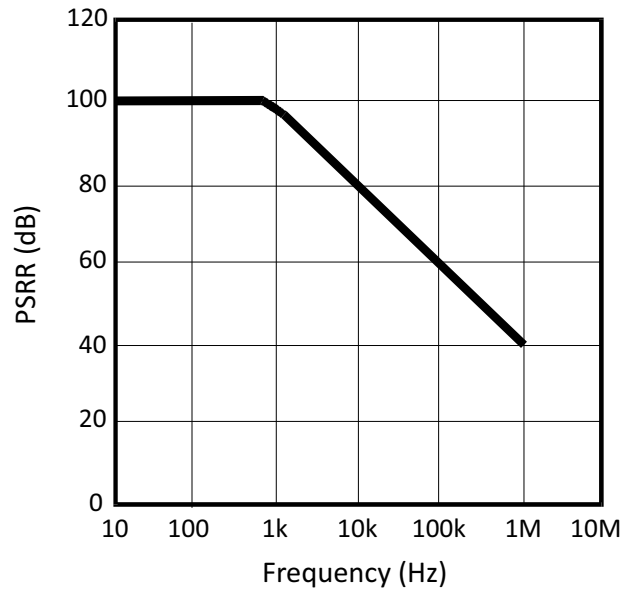
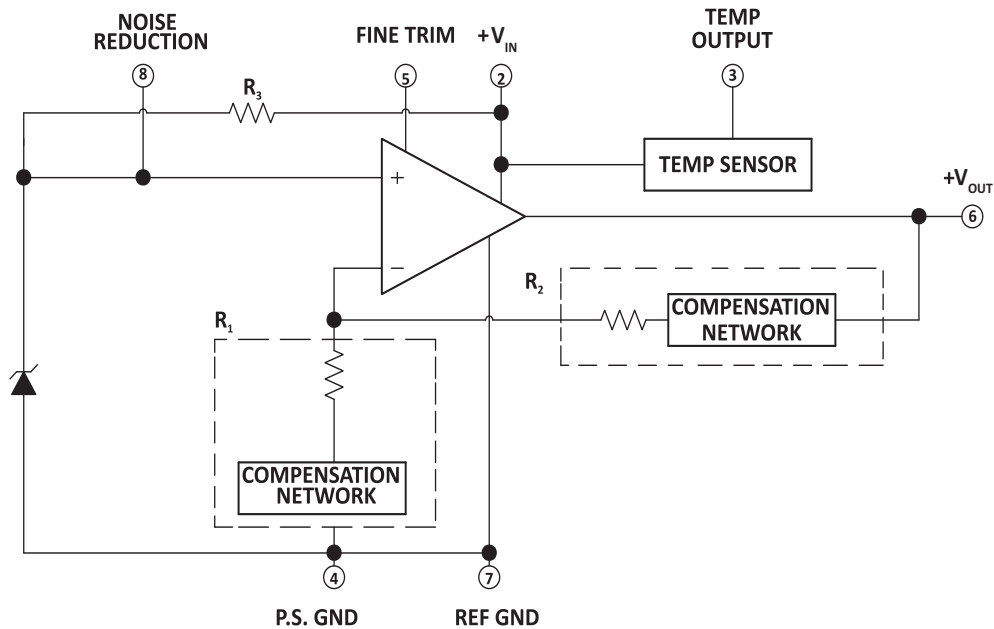

Figure 6: PSRR vs. Frequency



BLOCK DIAGRAM

Figure 7: Block Diagram



THEORY OF OPERATION

The following discussion refers to the block diagram in Figure 7. In operation, approximately 6.3V is applied to the noninverting input of the op amp. The voltage is amplified by the op amp to produce a 10V output. The gain is determined by the networks R1 and R2: $G=1 + R2/R1$. The 6.3V Zener diode is used because it is the most stable diode over time and temperature.

The Zener operating current is derived from the regulated output voltage through R3. This feedback arrangement provides a closely regulated Zener current. This current determines the slope of the references' voltage vs. temperature function. By trimming the Zener current a lower drift over temperature can be achieved. But since the voltage vs. temperature function is nonlinear this compensation technique is not well suited for wide temperature ranges.

A nonlinear compensation network of thermistors and resistors is used in the VRE series voltage references. This proprietary network eliminates most of the nonlinearity in the voltage vs. temperature function. By then adjusting the slope, a very stable voltage is produced over wide temperature ranges. This network is less than 2% of the overall network resistance so it has a negligible effect on long term stability. By using highly stable resistors in our network, we produce a voltage reference that also has very good long term stability.

The proper connection of the VRE310 series voltage references with the optional trim resistor is shown below. The VRE310 reference has the ground terminal brought out on two pins (pin 4 and pin 7) which are connected together internally. This allows the user to achieve greater accuracy when using a socket. Voltage references have a voltage drop across their power supply ground pin due to quiescent current flowing through the contact resistance. If the contact resistance was constant with time and temperature, this voltage drop could be trimmed out. When the reference is plugged into a socket, this source of error can be as high as 20ppm. By connecting pin 4 to the power supply ground and pin 7 to a high impedance ground point in the measurement circuit, the error due to the contact resistance can be eliminated. If the unit is soldered into place, the contact resistance is sufficiently small that it does not effect performance. Pay careful attention to the circuit layout to avoid noise pickup and voltage drops in the lines.

PIN CONFIGURATIONS

Figure 8: Pin Configurations

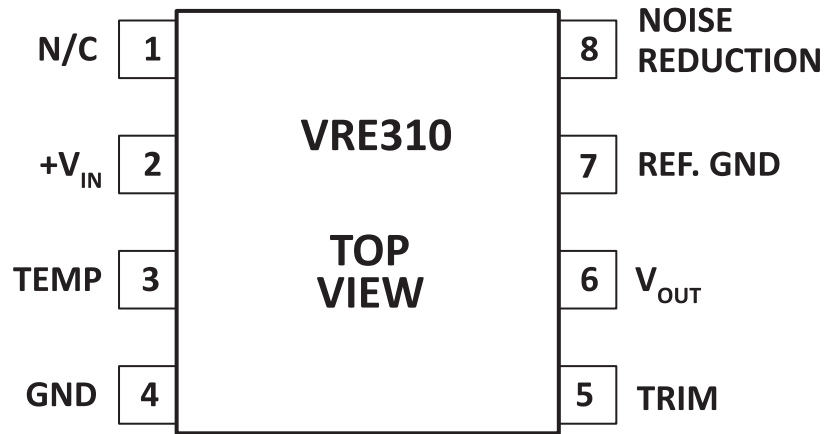

PACKAGE OPTIONS

Part Number	Apex Package Style	Description
VRE310AS	GD	8-pin Surface Mount DIP
VRE310AD	KD	8-pin DIP
VRE310JS	GD	8-pin Surface Mount DIP
VRE310JD	KD	8-pin DIP

PACKAGE STYLE KD

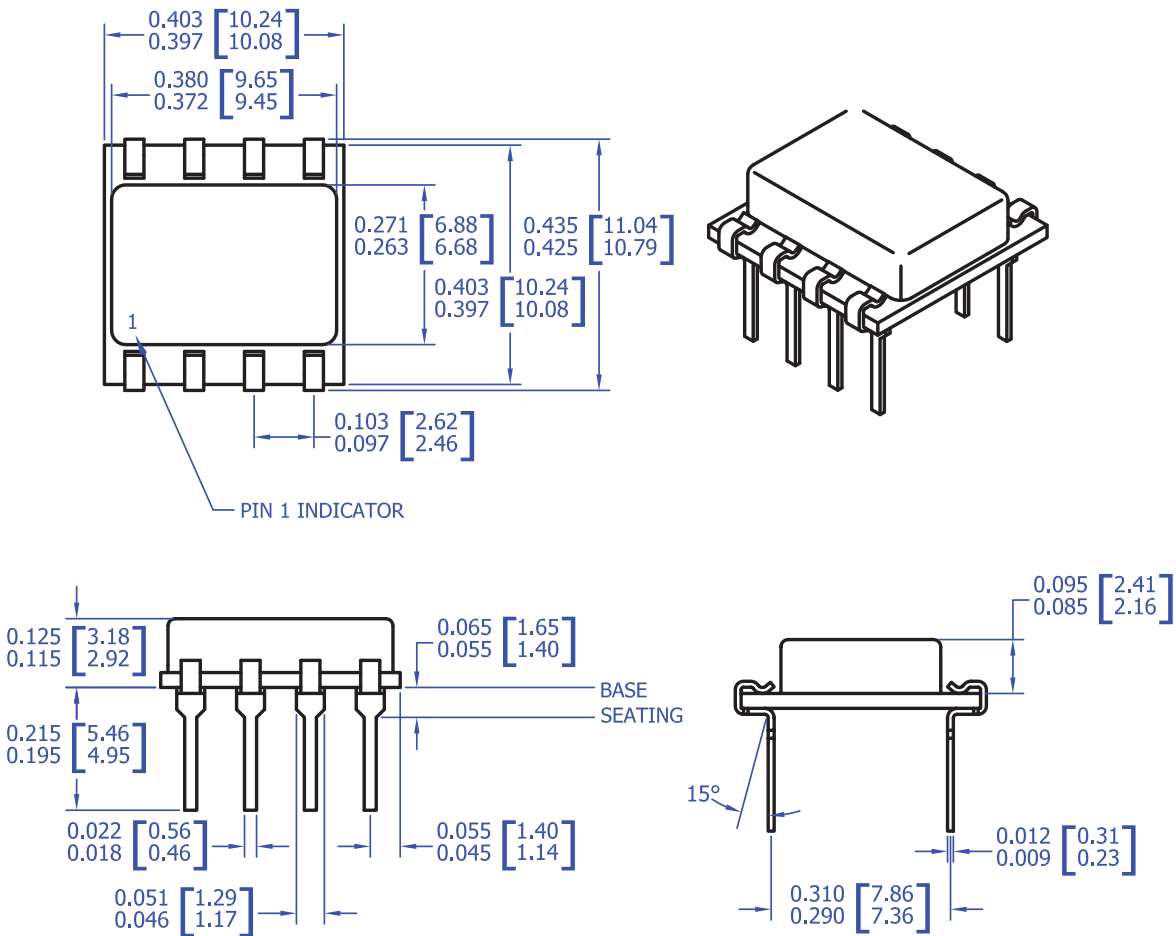

NOTES:

1. Dimensions are inches & [millimeters].
2. Bracketed alternate units are for reference only.
3. Pins: Phosphor bronze, Sn/Ag 96/4 solder dipped.
4. Material: Alumina Ceramic substrate and cover.
5. Package weight: 0.028 oz. [0.785 g].
6. Epoxy sealed, non-hermetic package