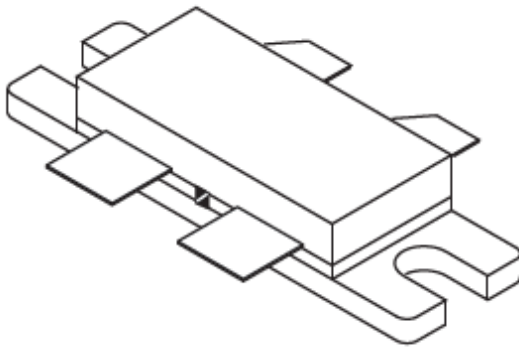

28 V, 300 W, 175 MHz Dual RF Power MOSFET

Product Overview

The VRF141G is designed for broadband commercial and military applications at frequencies to 175 MHz. The high power, high gain, and broadband performance of this device make possible solid state transmitters for FM broadcast or TV channel frequency bands.

**Features**

- Improved ruggedness $V_{(BR)DSS} = 80\text{ V}$
- 300 W with 14 dB typical gain at 175 MHz, 28 V
- Excellent stability and low IMD
- Common source push-pull configuration
- 5:1 load VSWR capability at specified operating conditions
- Nitride passivated
- Refractory gold metallization
- High voltage replacement for MRF141G
- RoHS compliant

1. Device Specifications

This section shows the specifications of the VRF141G device.

1.1 Absolute Maximum Ratings

The following table shows the absolute maximum ratings of the VRF141G device. $T_C = 25\text{ }^\circ\text{C}$ unless otherwise specified.

Table 1-1. Absolute Maximum Ratings

Symbol	Parameter	Ratings	Unit
V_{DSS}	Drain source voltage	80	V
I_D	Continuous drain current	40	A
V_{GS}	Gate-source voltage	± 40	V
P_D	Total power dissipation	500	W
T_{STG}	Storage temperature range	-65 to 150	$^\circ\text{C}$
T_J	Operating junction temperature	200	

1.2 Electrical Performance

The following table shows the static characteristics of the VRF141G device. $T_C = 25\text{ }^\circ\text{C}$ unless otherwise specified.

Table 1-2. Static Characteristics

Symbol	Characteristic	Test Conditions	Min	Typ	Max	Unit
$V_{(BR)DSS}$	Drain-source breakdown voltage	$V_{GS} = 0\text{ V}$, $I_D = 100\text{ mA}$	80	90		V
$V_{DS(ON)}$	On-state drain voltage	$I_{D(ON)} = 10\text{ A}$, $V_{GS} = 10\text{ V}$		1.0	1.4	
I_{DSS}	Zero gate voltage drain current	$V_{DS} = 60\text{ V}$, $V_{GS} = 0\text{ V}$			1.0	mA
I_{GSS}	Gate-source leakage current	$V_{DS} = \pm 20\text{ V}$, $V_{GS} = 0\text{ V}$			1.0	μA
g_{fs}	Forward transconductance	$V_{DS} = 10\text{ V}$, $I_D = 5\text{ A}$	5.0			mhos
$V_{GS(th)}$	Gate-source threshold voltage	$V_{DS} = 10\text{ V}$, $I_D = 100\text{ mA}$	2.9	3.6	4.4	V

The following table shows the thermal characteristics of the VRF141G device.

Table 1-3. Thermal Characteristics

Symbol	Characteristic	Min	Typ	Max	Unit
$R_{\theta JC}$	Junction-to-case thermal resistance			0.35	$^\circ\text{C/W}$

Note: These devices are sensitive to electrostatic discharge. Proper handling procedures should be followed.

The following table shows the dynamic characteristics of the VRF141G device. $T_C = 25\text{ }^\circ\text{C}$ unless otherwise specified.

Table 1-4. Dynamic Characteristics

Symbol	Characteristic	Test Conditions	Min	Typ	Max	Unit
C_{iss}	Input capacitance	$V_{GS} = 0\text{ V}, V_{DS} = 28\text{ V}, f = 1\text{ MHz}$		400		pF
C_{oss}	Output capacitance			375		
C_{rss}	Reverse transfer capacitance			50		

The following table shows the functional characteristics of the VRF141G device. $T_C = 25\text{ }^\circ\text{C}$ unless otherwise specified.

Table 1-5. Functional Characteristics

Symbol	Test Conditions	Min	Typ	Max	Unit
G_{PS}	$f_1 = 175\text{ MHz}, V_{DD} = 28\text{ V}, I_{DQ} = 500\text{ mA}, P_{out} = 300\text{ W}$	12	14		dB
η_D	$f_1 = 175\text{ MHz}, V_{DD} = 28\text{ V}, I_{DQ} = 500\text{ mA}, P_{out} = 300\text{ W}$	45	55		%
Ψ	$f_1 = 175\text{ MHz}, V_{DD} = 28\text{ V}, I_{DQ} = 500\text{ mA}, P_{out} = 300\text{ W}$ 5:1 VSWR — all phase angles	No degradation in output power			

1.3 Typical Performance Curves

This section shows the typical performance curves of the VRF141G device.

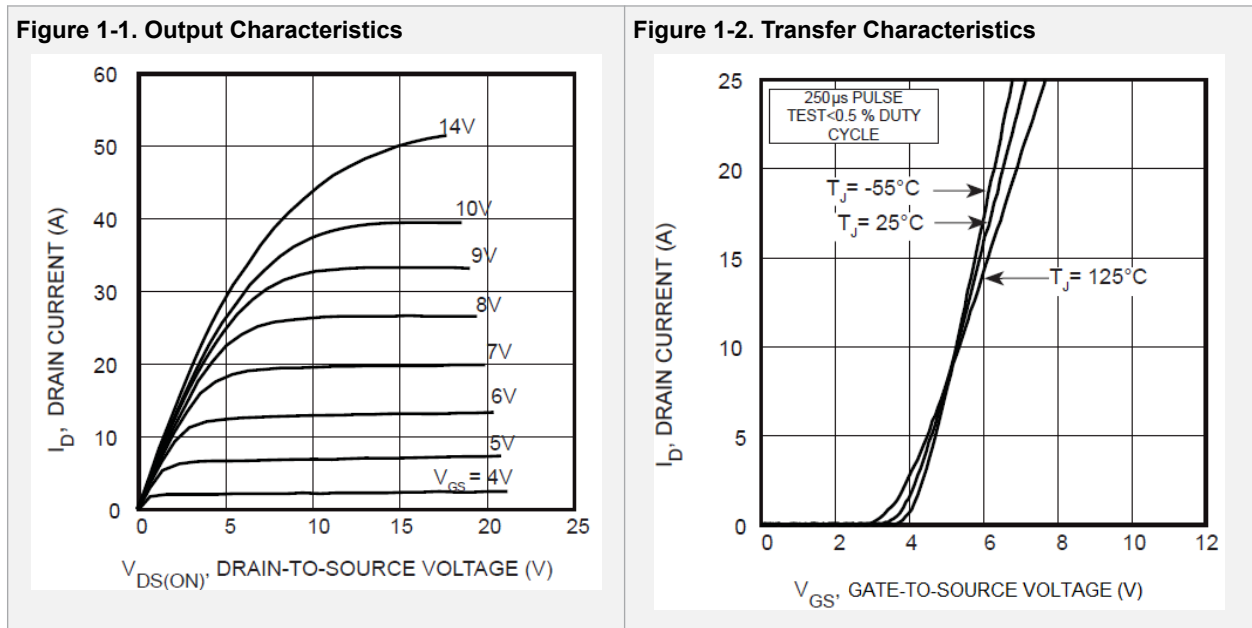

Figure 1-3. Capacitance vs. Drain-to-Source Voltage

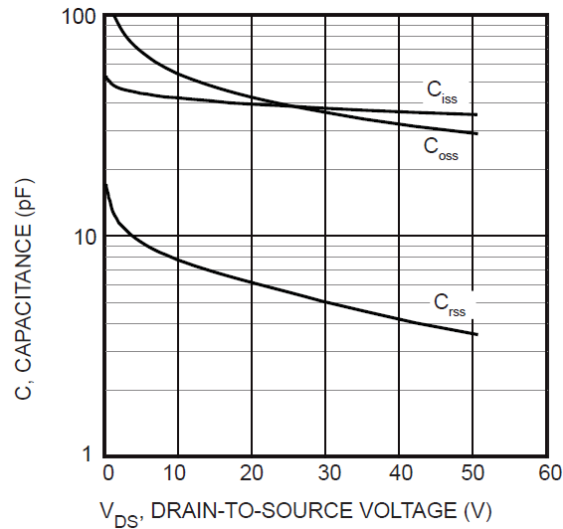

Figure 1-4. Forward Safe Operating Area

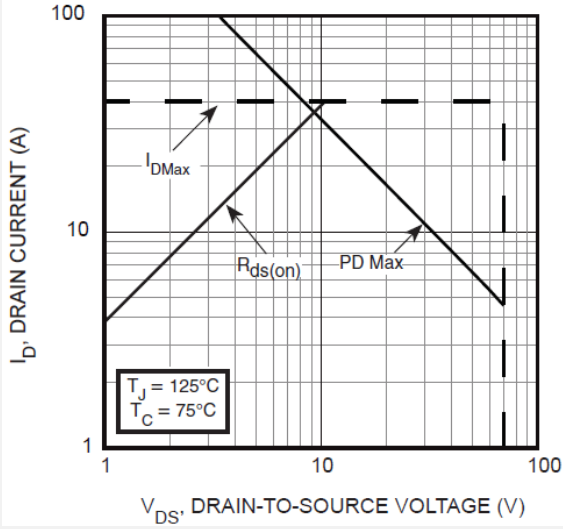
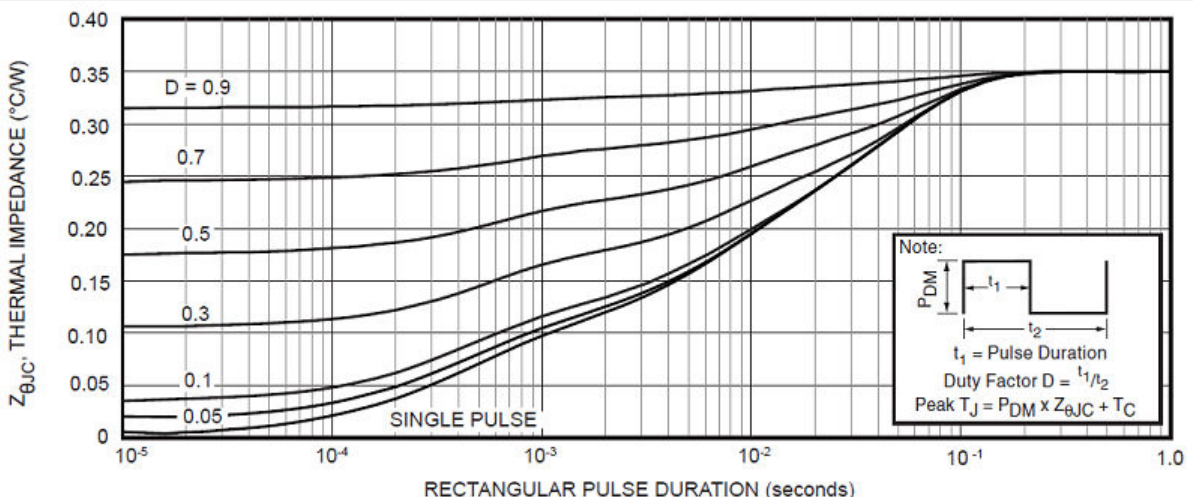

Figure 1-5. Maximum Effective Transient Thermal Impedance Junction-to-Case vs. Pulse Duration



2. Test Circuits

The following figure shows the test circuits of the VRF141G device.

Figure 2-1. 30 MHz Test Circuit

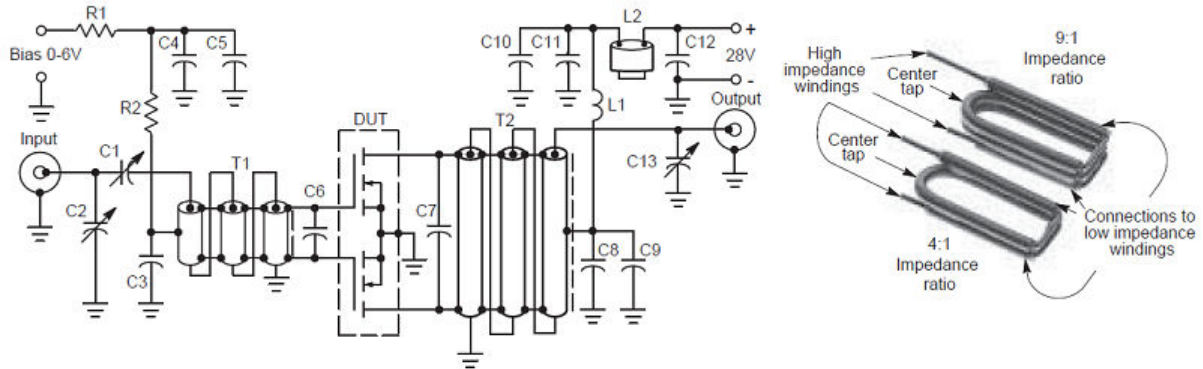

- C1 - Arco 402, 1.5 ±20 pF
- C2 - Arco 406, 15 ±115 pF
- C3, C4, C8, C9, C10 - 1000 pF Chip
- C5, C11 - 0.1 nF Chip
- C6 - 330 pF Chip
- C7 - 200 pF and 180 pF Chips in Parallel
- C12 - 0.47 nF Ceramic Chip, Kemet 1215 or Equivalent
- C13 - Arco 403, 3.0 ±35 pF
- L1 - 10 Turns AWG #16 Enameled Wire, Close Wound, 1/4, I.D.
- L2 - Ferrite Beads of Suitable Material for 1.5±2.0 nH Total Inductance
- R1 - 100 Ohms, 1/2 W
- R2 - 1.0 kOhm, 1/2 W

- T1 - 9:1 RF Transformer. Can be made of 15±18 Ohms Semirigid Co-ax, 62 ±90 Mils O.D.
- T2 - 1:9 RF Transformer. Can be made of 15±18 Ohms Semirigid Co-ax, 70 ±90 Mils O.D.

Board Material - 0.062", Fiberglass (G10), 1 oz. Copper Clad, 2 Sides, $\epsilon_r = 5$

NOTE: For stability, the input transformer T1 must be loaded with ferrite toroids or beads to increase the common mode inductance. For operation below 100 MHz. The same is required for the output transformer. See pictures for construction details.

Unless Otherwise Noted, All Chip Capacitors are ATC Type 100B or Equivalent.

3. Package Specification

This section shows the package specification of the VRF141G device.

3.1 Package Outline Drawing

The following figure illustrates the package outline of the VRF141G device.

Figure 3-1. M208 Package Outline

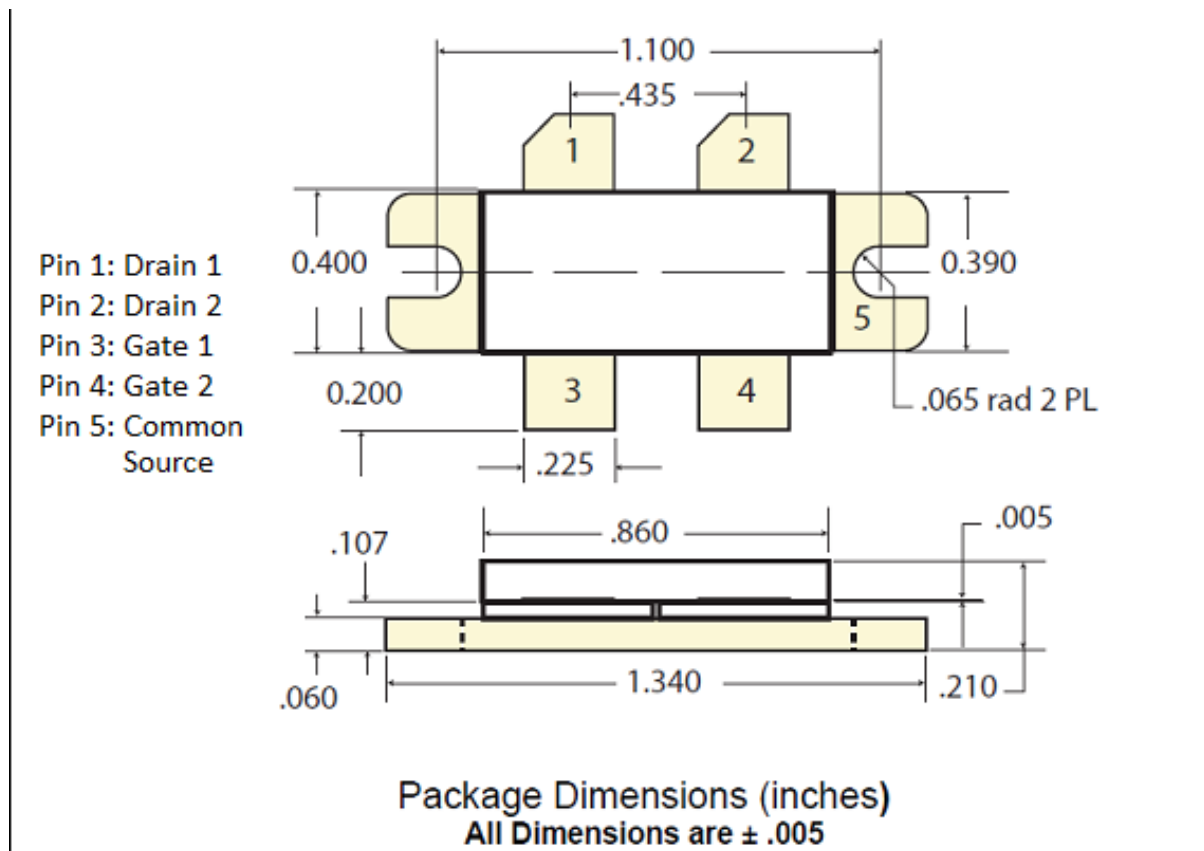

Note: Hazardous Material Warning!

The ceramic portion of the device between leads and mounting flange is beryllium oxide. Beryllium oxide dust is highly toxic when inhaled. Care must be taken during handling and mounting to avoid damage to this area. These devices must never be thrown away with general industrial or domestic waste.

4. Revision History

Table 4-1. Revision History

Revision	Date	Description
A	12/2021	<ul style="list-style-type: none">• Document migrated from Microsemi template to Microchip template; Assigned Microchip literature number DS-00004328A, which replaces the previous Microsemi literature number 050-4953.• Increased $V_{DS(on)}$ limit from 1.3V max. to 1.4V max.
Initial releases (Microsemi Revisions A and B)	06/2009 – 12/2020	Previous releases.

The Microchip Website

Microchip provides online support via our website at www.microchip.com/. This website is used to make files and information easily available to customers. Some of the content available includes:

- **Product Support** – Data sheets and errata, application notes and sample programs, design resources, user's guides and hardware support documents, latest software releases and archived software
- **General Technical Support** – Frequently Asked Questions (FAQs), technical support requests, online discussion groups, Microchip design partner program member listing
- **Business of Microchip** – Product selector and ordering guides, latest Microchip press releases, listing of seminars and events, listings of Microchip sales offices, distributors and factory representatives

Product Change Notification Service

Microchip's product change notification service helps keep customers current on Microchip products. Subscribers will receive email notification whenever there are changes, updates, revisions or errata related to a specified product family or development tool of interest.

To register, go to www.microchip.com/pcn and follow the registration instructions.

Customer Support

Users of Microchip products can receive assistance through several channels:

- Distributor or Representative
- Local Sales Office
- Embedded Solutions Engineer (ESE)
- Technical Support

Customers should contact their distributor, representative or ESE for support. Local sales offices are also available to help customers. A listing of sales offices and locations is included in this document.

Technical support is available through the website at: www.microchip.com/support

Microchip Devices Code Protection Feature

Note the following details of the code protection feature on Microchip products:

- Microchip products meet the specifications contained in their particular Microchip Data Sheet.
- Microchip believes that its family of products is secure when used in the intended manner, within operating specifications, and under normal conditions.
- Microchip values and aggressively protects its intellectual property rights. Attempts to breach the code protection features of Microchip product is strictly prohibited and may violate the Digital Millennium Copyright Act.
- Neither Microchip nor any other semiconductor manufacturer can guarantee the security of its code. Code protection does not mean that we are guaranteeing the product is "unbreakable". Code protection is constantly evolving. Microchip is committed to continuously improving the code protection features of our products.

Legal Notice

This publication and the information herein may be used only with Microchip products, including to design, test, and integrate Microchip products with your application. Use of this information in any other manner violates these terms. Information regarding device applications is provided only for your convenience and may be superseded by updates. It is your responsibility to ensure that your application meets with your specifications. Contact your local Microchip sales office for additional support or, obtain additional support at www.microchip.com/en-us/support/design-help/client-support-services.

THIS INFORMATION IS PROVIDED BY MICROCHIP "AS IS". MICROCHIP MAKES NO REPRESENTATIONS OR WARRANTIES OF ANY KIND WHETHER EXPRESS OR IMPLIED, WRITTEN OR ORAL, STATUTORY OR OTHERWISE, RELATED TO THE INFORMATION INCLUDING BUT NOT LIMITED TO ANY IMPLIED WARRANTIES OF NON-INFRINGEMENT, MERCHANTABILITY, AND FITNESS FOR A PARTICULAR PURPOSE, OR WARRANTIES RELATED TO ITS CONDITION, QUALITY, OR PERFORMANCE.

IN NO EVENT WILL MICROCHIP BE LIABLE FOR ANY INDIRECT, SPECIAL, PUNITIVE, INCIDENTAL, OR CONSEQUENTIAL LOSS, DAMAGE, COST, OR EXPENSE OF ANY KIND WHATSOEVER RELATED TO THE INFORMATION OR ITS USE, HOWEVER CAUSED, EVEN IF MICROCHIP HAS BEEN ADVISED OF THE POSSIBILITY OR THE DAMAGES ARE FORESEEABLE. TO THE FULLEST EXTENT ALLOWED BY LAW, MICROCHIP'S TOTAL LIABILITY ON ALL CLAIMS IN ANY WAY RELATED TO THE INFORMATION OR ITS USE WILL NOT EXCEED THE AMOUNT OF FEES, IF ANY, THAT YOU HAVE PAID DIRECTLY TO MICROCHIP FOR THE INFORMATION.

Use of Microchip devices in life support and/or safety applications is entirely at the buyer's risk, and the buyer agrees to defend, indemnify and hold harmless Microchip from any and all damages, claims, suits, or expenses resulting from such use. No licenses are conveyed, implicitly or otherwise, under any Microchip intellectual property rights unless otherwise stated.

Trademarks

The Microchip name and logo, the Microchip logo, Adaptec, AnyRate, AVR, AVR logo, AVR Freaks, BesTime, BitCloud, CryptoMemory, CryptoRF, dsPIC, flexPWR, HELDO, IGLOO, JukeBlox, KeeLoq, Klear, LANCheck, LinkMD, maXStylus, maXTouch, MediaLB, megaAVR, Microsemi, Microsemi logo, MOST, MOST logo, MPLAB, OptoLyzer, PIC, picoPower, PICSTART, PIC32 logo, PolarFire, Prochip Designer, QTouch, SAM-BA, SenGenuity, SpyNIC, SST, SST Logo, SuperFlash, Symmetricom, SyncServer, Tachyon, TimeSource, tinyAVR, UNI/O, Vectron, and XMEGA are registered trademarks of Microchip Technology Incorporated in the U.S.A. and other countries.

AgileSwitch, APT, ClockWorks, The Embedded Control Solutions Company, EtherSynch, Flashtec, Hyper Speed Control, HyperLight Load, IntellIMOS, Libero, motorBench, mTouch, Powermite 3, Precision Edge, ProASIC, ProASIC Plus, ProASIC Plus logo, Quiet- Wire, SmartFusion, SyncWorld, Temux, TimeCesium, TimeHub, TimePictra, TimeProvider, TrueTime, WinPath, and ZL are registered trademarks of Microchip Technology Incorporated in the U.S.A.

Adjacent Key Suppression, AKS, Analog-for-the-Digital Age, Any Capacitor, AnyIn, AnyOut, Augmented Switching, BlueSky, BodyCom, CodeGuard, CryptoAuthentication, CryptoAutomotive, CryptoCompanion, CryptoController, dsPICDEM, dsPICDEM.net, Dynamic Average Matching, DAM, ECAN, Espresso T1S, EtherGREEN, GridTime, IdealBridge, In-Circuit Serial Programming, ICSP, INICnet, Intelligent Paralleling, Inter-Chip Connectivity, JitterBlocker, Knob-on-Display, maxCrypto, maxView, memBrain, Mindi, MiWi, MPASM, MPF, MPLAB Certified logo, MPLIB, MPLINK, MultiTRAK, NetDetach, NVM Express, NVMe, Omniscient Code Generation, PICDEM, PICDEM.net, PICKit, PICTail, PowerSmart, PureSilicon, QMatrix, REAL ICE, Ripple Blocker, RTAX, RTG4, SAM-ICE, Serial Quad I/O, simpleMAP, SimpliPHY, SmartBuffer, SmartHLS, SMART-I.S., storClad, SQL, SuperSwitcher, SuperSwitcher II, Switchtec, SynchroPHY, Total Endurance, TSHARC, USBCheck, VariSense, VectorBlox, VeriPHY, ViewSpan, WiperLock, XpressConnect, and ZENA are trademarks of Microchip Technology Incorporated in the U.S.A. and other countries.

SQTP is a service mark of Microchip Technology Incorporated in the U.S.A.

The Adaptec logo, Frequency on Demand, Silicon Storage Technology, Symmcom, and Trusted Time are registered trademarks of Microchip Technology Inc. in other countries.

GestIC is a registered trademark of Microchip Technology Germany II GmbH & Co. KG, a subsidiary of Microchip Technology Inc., in other countries.

All other trademarks mentioned herein are property of their respective companies.

© 2021, Microchip Technology Incorporated and its subsidiaries. All Rights Reserved.

ISBN: 978-1-5224-9395-2

Quality Management System

For information regarding Microchip's Quality Management Systems, please visit www.microchip.com/quality.