

# Virtium TuffDrive<sup>®</sup> M.2 2242 – USB 3.1 Gen 1 SSD

## VTDUM4PI002G-ZTE Product Specification

---

### 1.0 Introduction

Virtium TuffDrive<sup>®</sup> M.2 SSDs are ideal solutions for server, networking, embedded and industrial applications that require a modest amount of storage and require a widely supported USB 3.1 Gen 1 interface. Typical applications include operating system and file storage, system level diagnostics, or as a backup repository for data in DRAM in the event of a system-level power-down.

### 2.0 Features

- Capacity: 2GB
- Industrial SLC
- Sustained Performance
  - Read: Up to 50MB/s
  - Write: Up to 40MB/s
- Temperature Range
  - Commercial: 0°C to 70°C
  - Industrial: -40°C to +85°C
  - Non-operating: -55°C to +95°C
- Power: 3.3V±5%
  - Maximum: 650mW
  - Typical: 570mW
  - Idle: 135mW
- Reliability
  - MTBF: 5,000,000 hours
  - SLC NAND endurance 100K @ 55°C
- Compliance
  - USB 3.1 Gen 1
  - RoHS
  - CE and FCC
- Operating System Support
  - Windows 7, Vista, XP, 200, ME, 98/98SE
  - Mac OS 9.x and above
  - Linux Kernel 2.4 and above
- Supports unique VID, PID, and serial number
- Mechanical Dimensions (M.2 2242 Form Factor)  
Length x Width x Height mm (inches)  
42.15 (1.659) x 22.15 (0.872) x 3.65 (0.144)
- Weight: 5 ±0.1g
- Environmental (Operating/Non-operating):
  - MIL-STD-810F
  - Shock: 1500G, 0.5ms duration
  - Vibration: 16.4G<sub>RMS</sub>



#### IMPORTANT!

Printed copies of this document are considered current only on the date of print. It is the responsibility of the user for the replacement and disposal of previous versions.

### 3.0 Ordering Information and Part Numbering System

#### 3.1 Part Number Decoder

#### V TD UM4 P I 002G - ZTE

Where:		
<b>V</b>	=	Virtium
<b>TD</b>	=	TuffDrive
<b>UM4</b>	=	Form Factor: M.2 2242; Interface: USB 3.1 Gen 1
<b>P</b>	=	PE Class, SLC
<b>I</b>	=	Operating Temperature: I = Industrial (-40°C to 85°C)
<b>002G</b>	=	Capacity: 002G = 2GB (1GB = 1,000,000,000)
<b>ZTE</b>	=	Virtium Proprietary

#### 3.2 Ordering Information

Part Number	Capacity
VTDUM4PI002G-ZTE	2GB

## Table of Contents

<b>1.0</b>	<b>Introduction</b> .....	<b>1</b>
<b>2.0</b>	<b>Features</b> .....	<b>1</b>
<b>3.0</b>	<b>Ordering Information and Part Numbering System</b> .....	<b>2</b>
3.1	Part Number Decoder .....	2
3.2	Ordering Information .....	2
<b>4.0</b>	<b>Specifications</b> .....	<b>4</b>
4.1	Capacity .....	4
4.2	Performance .....	4
4.3	Environmental Specifications.....	4
4.3.1	Temperature and Humidity.....	4
4.3.2	Shock and Vibration .....	4
4.3.3	Mean Time Between Failures (MTBF) .....	5
4.4	Power Requirements .....	5
4.5	SMART Attributes .....	5
<b>5.0</b>	<b>Physical Specifications</b> .....	<b>7</b>
5.1	Pin Assignments .....	7
5.2	Mechanical Dimensions .....	8
5.3	Connector Details .....	9
<b>6.0</b>	<b>Certifications and Compliance</b> .....	<b>9</b>
<b>7.0</b>	<b>Revision History</b> .....	<b>10</b>

## List of Tables

Table 1: Capacity .....	4
Table 2: Read/Write Performance.....	4
Table 3: Temperature and Humidity.....	4
Table 4: Shock and Vibration .....	4
Table 5: Power Consumption .....	5
Table 6: SMART Attribute Definitions .....	5
Table 7: Pin Assignments .....	7
Table 8: Certifications and Compliance .....	9

## List of Figures

Figure 1: Mechanical Dimensions .....	8
Figure 2: Connector Details .....	9

## 4.0 Specifications

### 4.1 Capacity

**Table 1: Capacity**

Unformatted Capacity (GB) <sup>(1)</sup>	User-Addressable LBA <sup>(2)</sup>	User-Addressable Capacity (Bytes)
2GB	TBD	TBD

(1) 1GB = 1,000,000,000 bytes.

(2) LBA: Logical Block Address. Logical block size of 512 bytes (1 sector).

### 4.2 Performance

**Table 2: Read/Write Performance**

Capacity	Transfer <sup>(1)</sup>	Value	Units
2GB	Sustained Read (max)	50	MB/s
	Sustained Write (max)	40	MB/s

(1) CrystalDiskMark 3.0.3

### 4.3 Environmental Specifications

#### 4.3.1 Temperature and Humidity

**Table 3: Temperature and Humidity**

Part Number	Operating Temperature	Non-Operating Temperature	Moisture Sensitivity (Non-Condensing)
VTDUM4PI002G-ZTE	-40°C to 85°C	-55°C to 96°C	5% to 95%

#### 4.3.2 Shock and Vibration

**Table 4: Shock and Vibration**

Reliability	Test Conditions
Shock <sup>(1)</sup>	1500G, half-sine, 0.5ms duration
Vibration <sup>(2)</sup>	16.4G <sub>RMS</sub>

(1) MIL-STD-810F, Method 516.5

(2) MIL-STD-810F, Method 514.5

### 4.3.3 Mean Time Between Failures (MTBF)

The TuffDrive achieves a MTBF of 5,000,000 hours predicted based on the component reliability data using Telcordia SR-332 methods at 40°C.

### 4.4 Power Requirements

The device requires a 3.3V±5% power supply.

**Table 5: Power Consumption**

Voltage	Maximum <sup>(1)</sup>	Typical <sup>(2)</sup>	Idle
3.3V	650mW	570mW	135mW

- (1) Maximum power consumption measured on 4GB TuffDrive SSD, 100% 64KB sequential writes.  
 (2) For a 70/30 read/write workload.

### 4.5 SMART Attributes

The following table lists the current SMART data attributes that are supported. Customers may view this data using the Linux `SMARTmontools` package. This package and the associated `smartctl` command should be used with options `-a`, `-i`, and `-d sat` for best viewing. The command `$ smartctl -d sat -a -i /dev/sdb` was used to retrieve the data below.

**Table 6: SMART Attribute Definitions**

Attribute ID (Hexadecimal)	Attribute ID (Decimal)	Attribute Name	Attribute Description
0x0C	12	Power Cycle Count	Number of Power On Cycles
0xC2	194	Temperature	Not used.
0xC4	196	Spare Block Count	The amount of available spare blocks. The attribute value returned is the percentage of remaining spare blocks summed over all flash chips, i.e., (100 × Current Spare Blocks / Initial Spare Blocks).
0xC7	199	UDMA CRC Error Rate	Not used. Included for compatibility.
0xCB	203	ECC Error Count	Total number of ECC errors correctable and uncorrectable for the NAND data.
0xCC	204	Number of Corrected ECC Errors	The total number of correctable ECC errors that have occurred on flash read commands.
0xD5	213	Reserved	Reserved
0xD6	214	Reserved	Reserved

<b>Attribute ID (Hexadecimal)</b>	<b>Attribute ID (Decimal)</b>	<b>Attribute Name</b>	<b>Attribute Description</b>
0xE5	229	Erase Count	The value returned is an estimation of the remaining card life, expressed as a percentage according to the number of flash block erases compared to the target number of erase cycles per block.
0xE8	232	Number of Reads	The total number of flash read commands.
0xF1	241	Total LBAs Written	Total number of LBAs written to the disk, divided by 65536.
0xF2	242	Total LBAs Read	Total number of LBAs read from the disk, divided by 65536.

## 5.0 Physical Specifications

### 5.1 Pin Assignments

**Table 7: Pin Assignments**

Pin	Signal Name	Description	Pin	Signal Name	Description
			75	CONFIG_2	TBD
74	V33	3.3V Power (±5%)	73	GND	Ground
72	V33	3.3V Power (±5%)	71	GND	Ground
70	V33	3.3V Power (±5%)	69	CONFIG_1	TBD
68	SUSCLK	No Connect	67	RESET#	No Connect
<b>Add-In Card Key M</b>					
58	N/C	No Connect			
56	N/C	No Connect	57	GND	Ground
54	PEWAKE#	No Connect	55	REFCLKp	Input
52	CLKREQ#	Ground	53	REFCLKn	Input
50	RESET#	Reset 1.8V	51	GND	Ground
48	GPIO_4	No Connect	49	PERp0/SATA-A+	No Connect
46	GPIO_3	No Connect	47	PERn0/SATA-A-	No Connect
44	GPIO_2	No Connect	45	GND	Ground
42	GPIO_1	No Connect	43	PERp0/SATA-B-	No Connect
40	GPIO_0	No Connect	41	PERn0/SATA-B+	No Connect
38	DEVSLP	TBD	39	GND	Ground
36	UIM-POWER (I)	No Connect	37	USB3.1-Rx+	USB SuperSpeed Receive Differential Signal+
34	UIM-DATA (I/O)	No Connect	35	USB3.1-Rx-	USB SuperSpeed Receive Differential Signal-
32	UIM-CLOCK (O)	No Connect	33	GND	Ground
30	UIM-RESET (O)	No Connect	31	USB3.1-Tx+	USB SuperSpeed Transmit Differential Signal+
28	GPIO_8	No Connect	29	USB3.1-Tx-	USB SuperSpeed Transmit Differential Signal-
26	GPIO_10	No Connect	27	GND	Ground
24	GPIO_7	No Connect	25	GPIO_12	No Connect
22	GPIO_6	No Connect	23	GPIO_11	No Connect
20	GPIO_5	No Connect	21	CONFIG_0	Ground
<b>Add-In Card Key B</b>					
			11	GND	Ground
10	Vendor-Defined	Vendor-Defined	9	USB_D-	USB Data Differential Signal-
8	W_Disable#1	No Connect	7	USB_D+	USB Data Differential Signal+
6	Full_Card_Power_Off	No Connect	5	GND	Ground
4	V33	3.3V Power (±5%)	3	GND	Ground
2	V33	3.3V Power (±5%)	1	CONFIG_3	Ground

## 5.2 Mechanical Dimensions

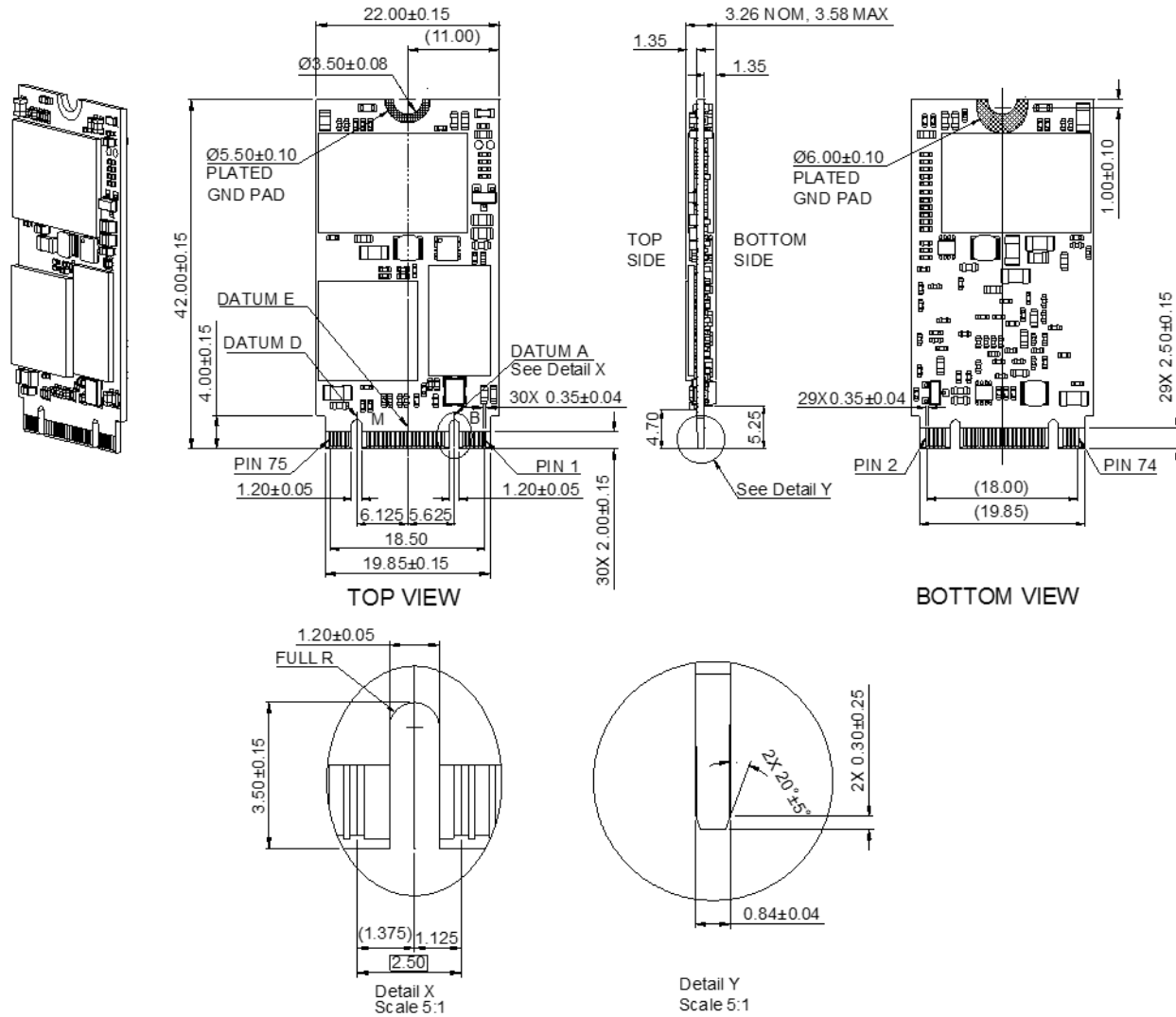

**NOTES:**

1. All dimensions are in millimeters (mm).

**Figure 1: Mechanical Dimensions**



### 5.3 Connector Details

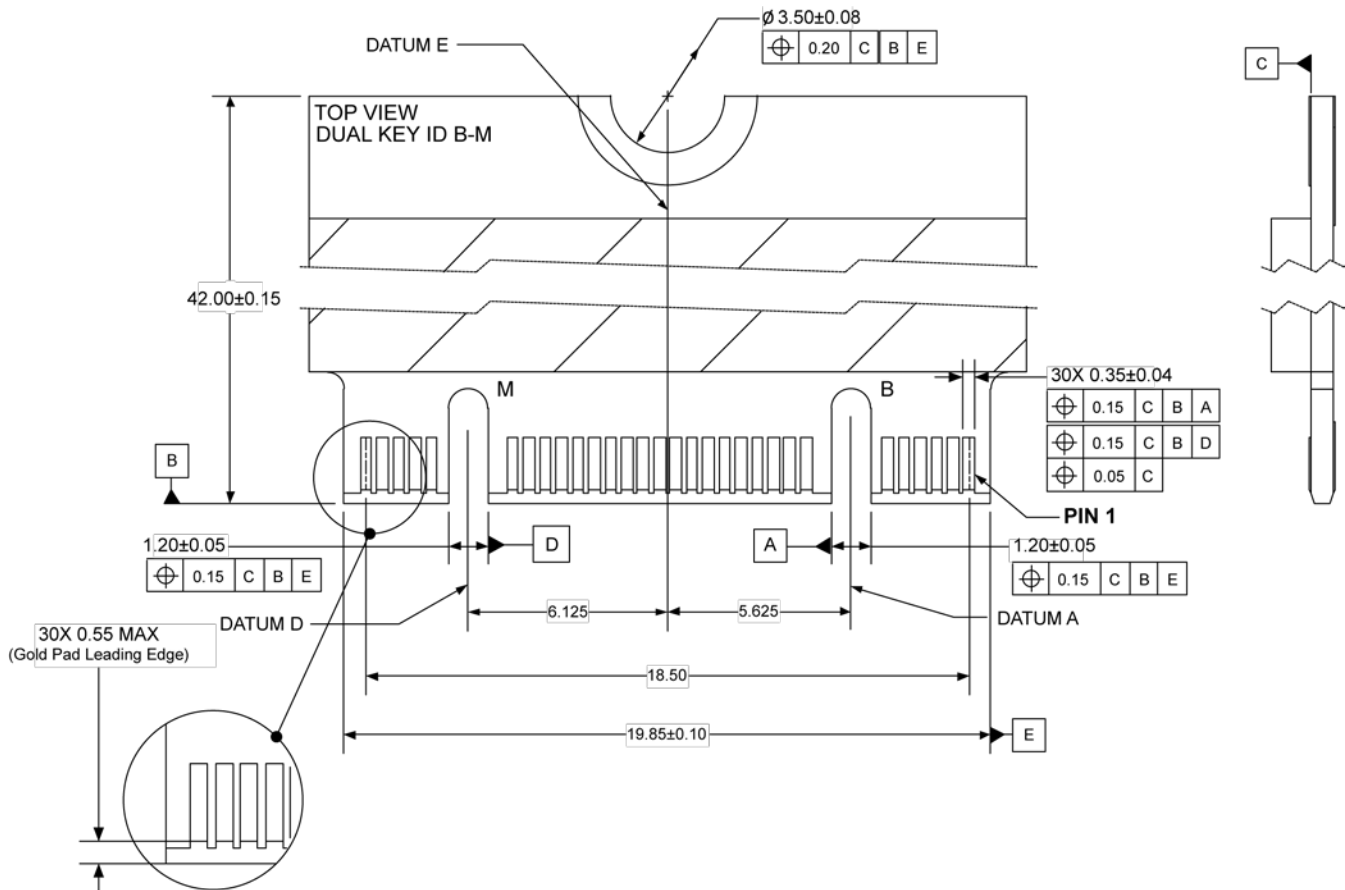

Figure 2: Connector Details

## 6.0 Certifications and Compliance

Table 8: Certifications and Compliance

Compliance/Certification	Description
CE and FCC Compliant	Class: FCC Part 15 Subpart B Class B:2011; Declaration of Conformity. Registration STE120607699
RoHS Compliant	Restriction of Hazardous Substance Directive
UL Certified	Underwriters Laboratories, Inc. 94V-0
WEEE Certified	Waste, Electrical and Electronic Equipment Directive