

DRAWING FOR REFERENCE: This is subject to change without notice
08/11/2012

1 2 3 4 5 6 7 8

EMBOSSED TAPING DRAWING(4:1)

DIRECTION OF UNREELING

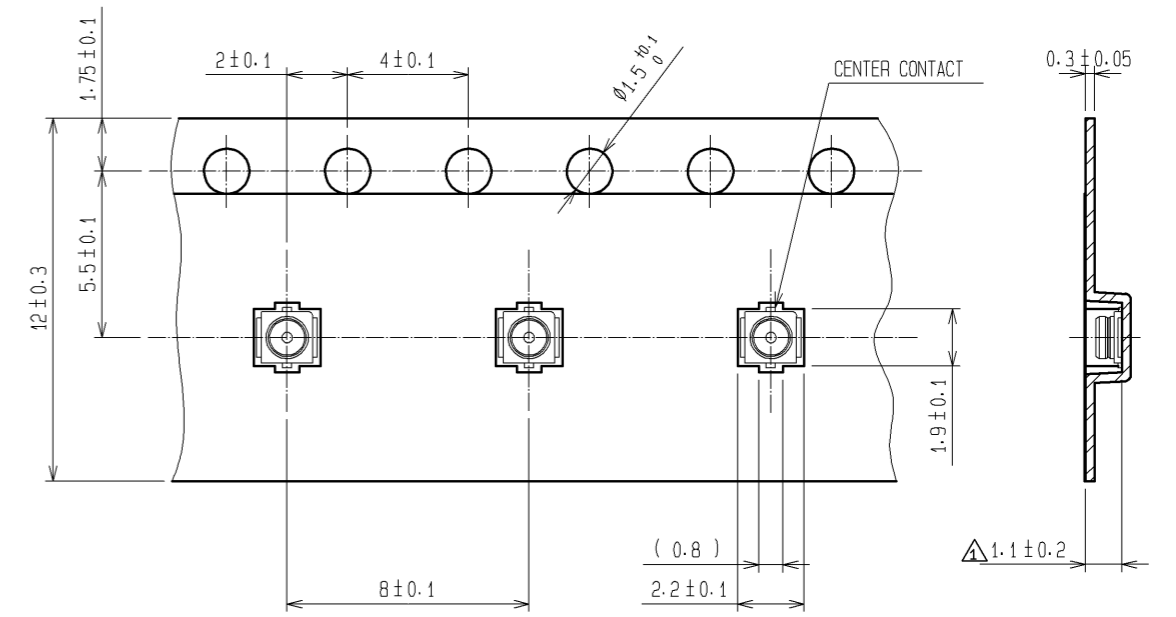
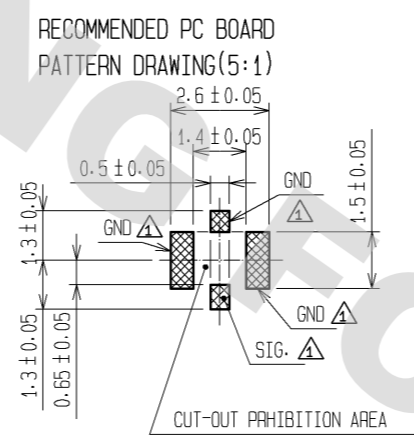
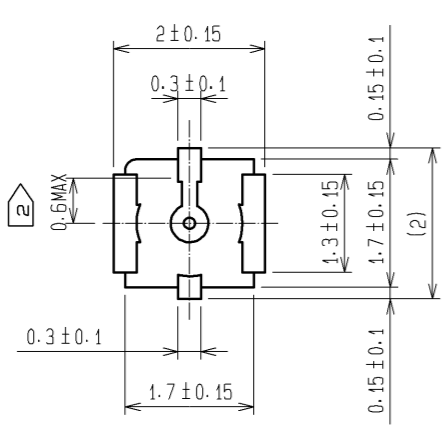
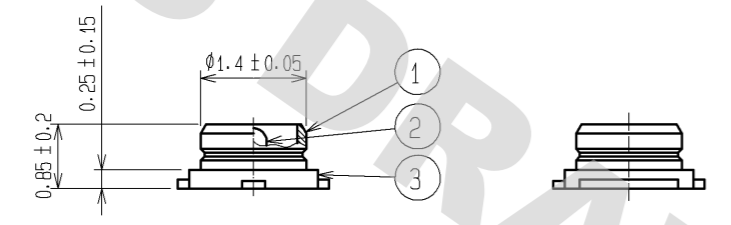
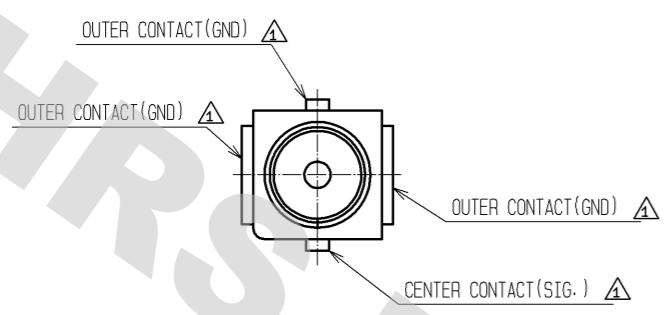

MOUNTING TEMPERATURE PROFILE (REFERENCE)

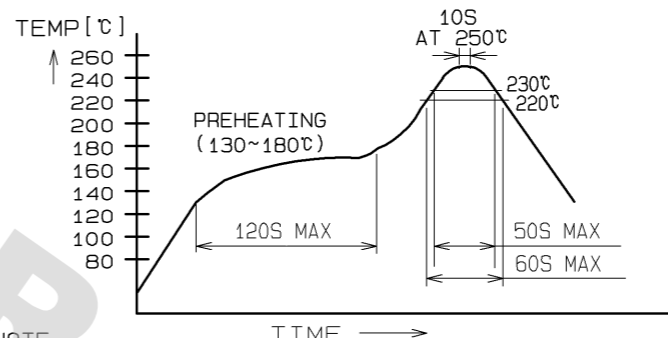

NOTE
MOUNTING TEMPERATURE PROFILE VARIES ACC TO BOARD SIZE, SOLDER TYPE APPLIED AND SOLDER THICKNESS.
·METAL MASK THICKNESS: 0.1mm / 0.12mm
·Up to 2cycles of Reflow.

REEL DRAWING(SCALE FREE)

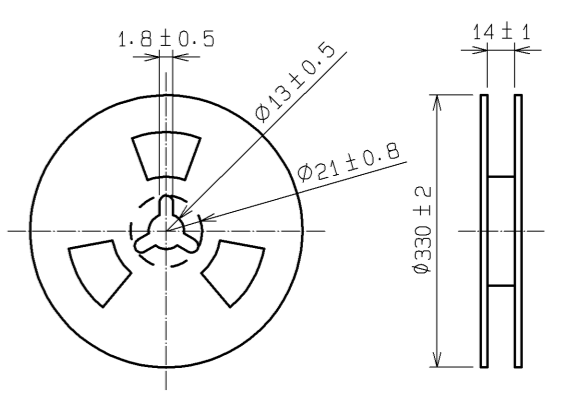

NOTES:

- 1: THE QUANTITY OF W.FL-R-SMT-1(10) IS 2000 CONNECTORS PER REEL.
- 2: THIS DIMENSION SHOWS THE ALLOWABLE RANGE THAT THE RESIN IS PUT OVER THE CENTER CONTACT.
- 3: LEAD CO-PLANARITY SHALL BE 0.1MAX.
- 4: FOR THE POSSIBILITY OF BREAKAGE OR DEFORMATION DO NOT MATE THIS CONNECTOR WITH PARTNER, W.FL-LP-040 BEFORE MOUNTING ON PC BOARD.
- 5: USE ALL PRODUCTS WITHIN 6 MONTHS AFTER THE DELIVERY. STORE THEM IN MANUFACTURER'S PACKAGE OR TIGHTLY RE-CLOSED BOX WITH THE FOLLOWING CONDITIONS. CHECK THE TERMINAL SOLDERABILITY BEFORE USE IF THE PRODUCT HAS BEEN STORED FOR MORE THAN 6 MONTHS.
TEMPERATURE: -10°C TO +40°C
HUMIDITY : 15 TO 85% RH.
- 6: ENVIRONMENTAL CONDITIONS DO NOT USE THE PRODUCTS UNDER THE ENVIRONMENTAL CONDITIONS AS SHOWN BELOW DUE TO POSSIBLE PRODUCT DETERIORATION.
SPECIAL GAS ATMOSPHERE(HYDROGEN SULFIDE GAS, SULFUR SULFIDE GAS AND HYDROGEN CHLORIDE GAS)
PLACE ATTENTION REQUIRED: HEATING SYSTEM, AREA NEAR HOT SPRING, VOLCANIC MOUNTAIN AND ALIKE.
WATER SPLACHED AND CONDENSATION PLACES.
PLACE ATTENTION REQUIRED: HARSH TEMPERATURE CHANGE.

2	BRASS	GOLD PLATING		3	LCP	(BLACK)·UL94V-0	
1	PHOSPHOR BRONZE	SILVER PLATING					
NO.	MATERIAL	FINISH, REMARKS		NO.	MATERIAL	FINISH, REMARKS	
UNITS	mm	SCALE	10:1	COUNT	3	DESCRIPTION OF REVISIONS	DIS-D-001378
		DESIGNED	YI. FUNADA	CHECKED	NK. NINOMIYA	DATE	09.03.12
APPROVED: IJ. MITANI		05.01.05		DRAWING NO.		EDC3-138509-10	
CHECKED: MH. YAMANE		05.01.05		PART NO.		W.FL-R-SMT-1(10)	
DESIGNED: NK. NINOMIYA		05.01.05		CODE NO.		CL331-0482-6-10	
DRAWN: MA. SAEKI		05.01.05				1/1	