

NEW.

Now including
NexGen 100 GHz
WSMP® Connectors

Rosenberger

WSMP® Coaxial RF Connectors & Cable Assemblies for High Density Applications

ROSENBERGER NORTH AMERICA

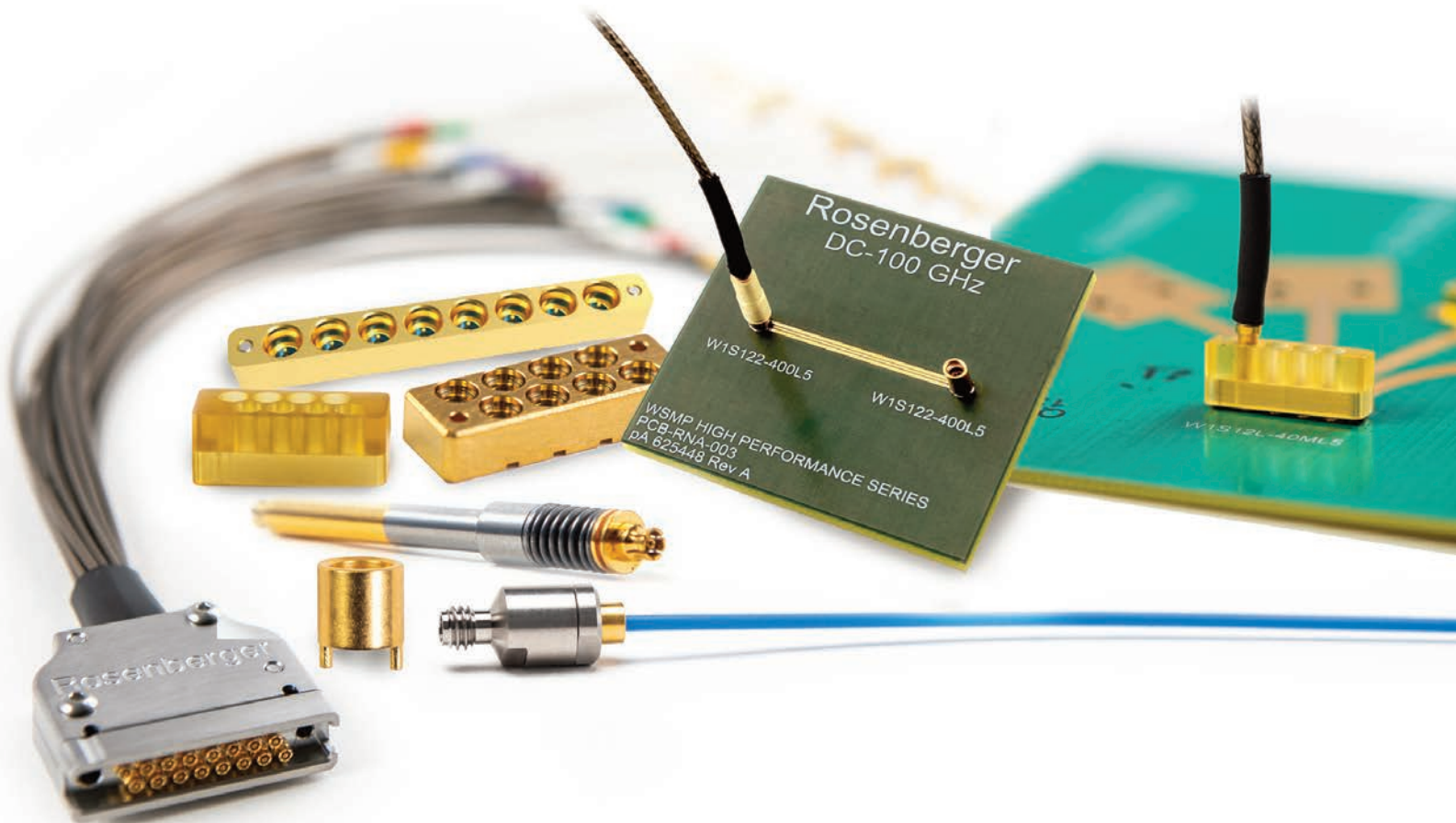

Standard WSMP[®] Connectors

Specifications

Interface According to Rosenberger WSMP [®] Interface standards		Mechanical data Engagement force (typical) Full Detent (FD) 11 N 2.47 Lbs. Smooth Bore (SB) 5.3 N 1.19 Lbs. Disengagement force (typical) Full Detent (FD) 20 N 4.5 Lbs. Smooth Bore (SB) 4.45 N 1.0 Lbs. Axial Misalignment .000-.010 inches [.000 - .250mm] Radial Misalignment ±.005 inches [+/- .13mm]	
Material and plating Connector parts Material Plating Center contact Kovar [®] or CuBe Gold Outer contact Kovar [®] or CuBe Gold Dielectric PTFE, PAI, or Corning 7070 [™] Glass		Environmental data Temperature range -55° C to +165° C Thermal shock MIL-STD-202, Meth. 107, Cond. B Corrosion MIL-STD-202, Meth. 101 Vibration MIL-STD-202, Meth. 204, Cond. D Shock MIL-STD-202, Meth. 213, Cond. I Moisture resistance MIL-STD-202, Meth. 106, except Step 7B Max. soldering temperature (optional) IEC 61760-1, +260°C for 10 sec. RoHS Compliant Hermetically-sealed to 1 x 10 ⁻⁸ cc/sec On Request	
Electrical data Impedance 50 Ω Frequency DC to 65 GHz Return loss (typical) ≥ 26 dB, DC to 26.5 GHz ≥ 19 dB, 26.5 to 65 GHz Insertion loss ≤ 0.12 x √f(GHz) dB Insulation resistance ≥ 3.5 x 10 ³ MΩ Center contact resistance ≤ 6.0 mΩ Outer contact resistance ≤ 2.0 mΩ Test voltage (at sea level) 250 Vrms RF High Potential (at sea level) 150 Vrms @ 5 MHz RF-leakage (optional) ≥ -80 dB (typical mated pair) @ 30 GHz		Tooling WSMP Cable Connector Prybar W1W001-000 WSMP Right Angle Prybar Extraction Tool W1W005-000 WSMP Bullet Insertion/ Extraction Tool W1W002-000	
Mechanical data Mating cycles Full Detent (FD) ≥ 100 Smooth Bore (SB) ≥ 500			

Cable Connectors

Description

WSMP Female Straight for .047 Cable

Part Number

W1K101-270D3

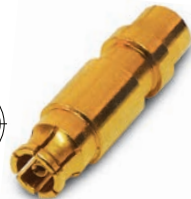
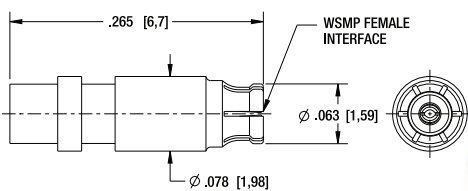

Description

WSMP Female Right Angle for .047 Cable

Part Number

W1K203-270D3

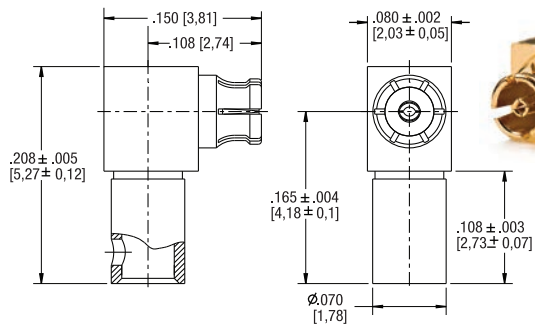

Description

WSMP Male Straight for .047 Cable

Part Number

FD: W1S101-270D3
SB: W1S141-270D3

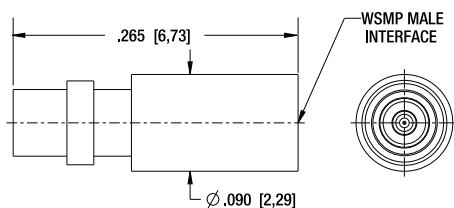

Description

WSMP Male Straight Bulkhead for .047 Cable

Part Number

FD: W1S501-270D3
SB: W1S541-270D3

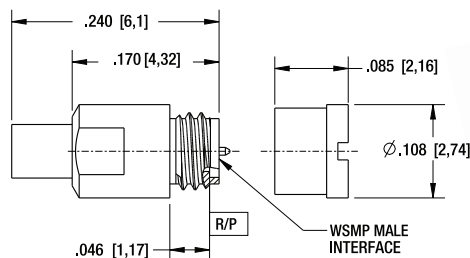

Standard WSMP[®] Connectors

PCB Connectors

Description

WSMP Male PCB, Straight,
SMT, J-Lead
WSMP Male, PCB, Straight,
with SMT p/u cap

Part Number

FD: W1S103-40ML5
SB: W1S143-40ML5
FD: W1S109-40ML5
SB: W1S149-40ML5

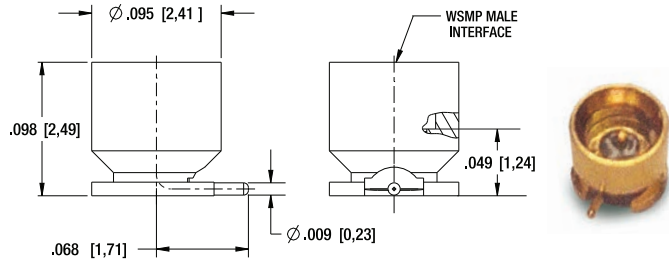

Description

WSMP Male PCB Edge Mount

Part Number

FD: W1S204-40ML5
SB: W1S244-40ML5

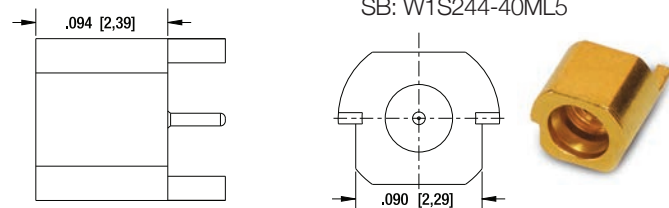

Description

WSMP Male PCB, Straight,
SMT, J-Lead, Multiport Arrays

Part Number

FD: 2 Port: W1S12A 40ML5
FD: 4 Port: W1S12B-40ML5
SB: 2 Port: W1S15A-40ML5
SB: 4 Port: W1S15B-40ML5

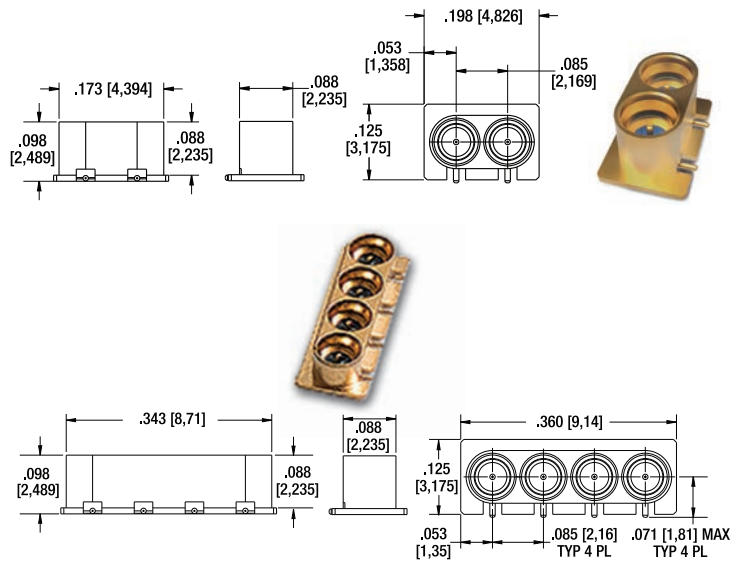

Hermetic

Description

WSMP Straight, PCB plug,
solder-in hermetic

Part Number

FD: W1S101-5H0L5
SB: W1S141-40ML5

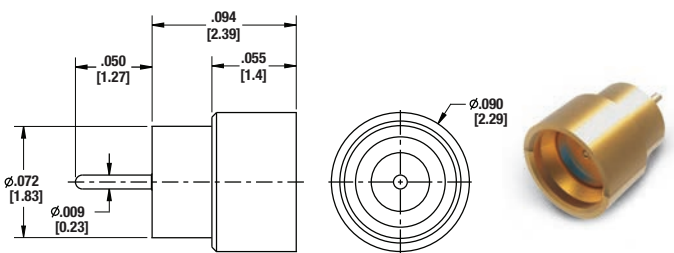

Shroud/Pin

Description

WSMP Straight, PCB plug,
pin/shroud kit

Part Number

FD: W1S104-40ML5
SB: W1S144-40ML5

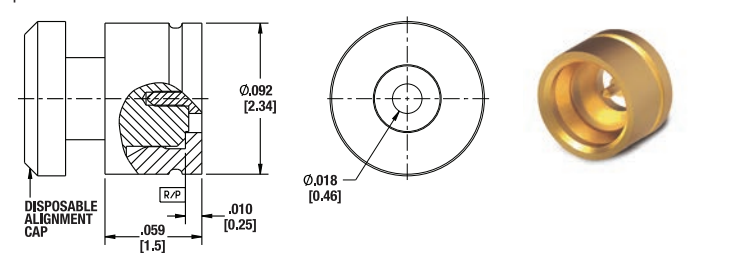

Adapters

Description

WSMP Female Blindmate Interconnect (Bullet)

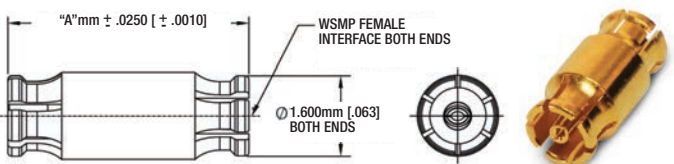

Part Number	A (mm)	A (in)	Part Number	A (mm)	A (in)
W1K10A-K00D3	2.49	0.098	W1K10J-K00D3	7.62	0.300
W1K10C-K00D3	3.18	0.125	W1K10M-K00D3	10.16	0.400
W1K10F-K00D3	3.81	0.150	W1K10N-K00D3	12.70	0.500
W1K10G-K00D3	5.08	0.200	W1K10P-K00D3	15.24	0.600
W1K10H-K00D3	6.35	0.250			

Additional lengths available on request

Compressible Adapters

Description

Compressible Bullet

Part Number

W1KF1W1-K03D3

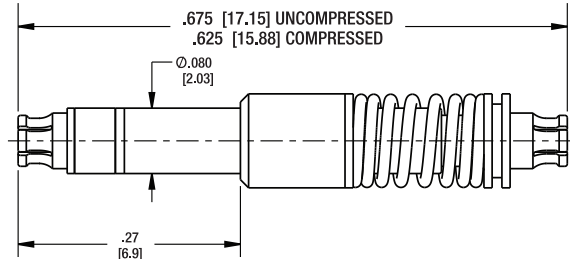

Custom sizes available upon request, please consult the factory.

High Speed Applications

Applications include:

- Optical Transceivers
- 100G – 400G Optical Network Applications
- Laser Modulators
- Typical application: Integrated Polarization Multiplexed Quadrature Modulators according to OIF_HBPMQ-TX-010

Description

WSMP Male, Full Detent, 4 port SMT

Part Number

FD: W1S20M-40ME4

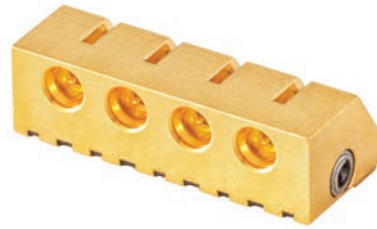
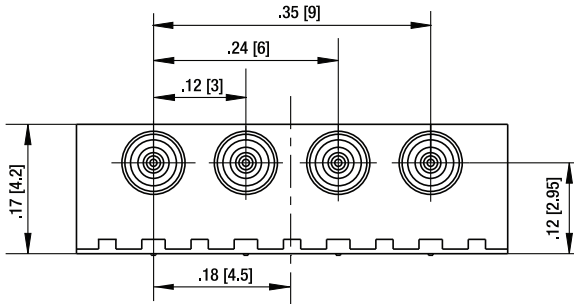

Edge Launch WSMPs



Description

WSMP Male, 4-port, edge launch

Part Number

FD: W1S20J-40ML5
SB: W1S24J-40ML5

WSMP Male, 8-port, edge launch

FD: W1S20H-40ML5
SB: W1S24H-40ML5

Hermetic WSMPs

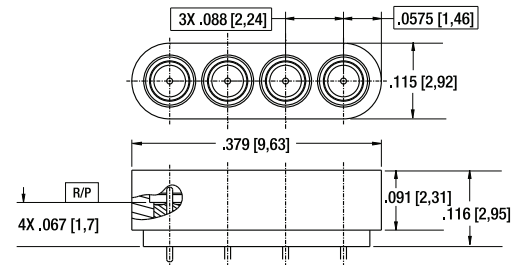

Description

WSMP Male, 4-port, vertical launch

Part Number

FD: W1S10Z-40ML5
SB: W1S14Z-40ML5

WSMP Male, 8-port, vertical launch

FD: W1S10S-40ML5
SB: W1S14S-40ML5

Please contact the factory for further information and product availability of our High Speed products.

Adapters

Description

WSMP Female Blindmate Interconnect (Bullet)

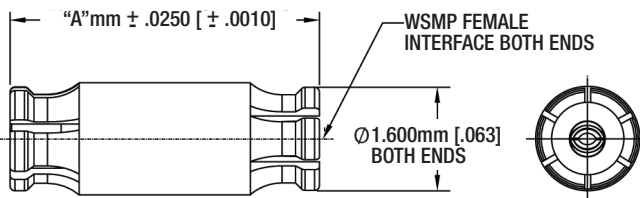

Part Number	A (mm)	A (in)	Part Number	A (mm)	A (in)
W1K10A-K00D3	2.49	0.098	W1K10J-K00D3	7.62	0.300
W1K10C-K00D3	3.18	0.125	W1K10M-K00D3	10.16	0.400
W1K10F-K00D3	3.81	0.150	W1K10N-K00D3	12.70	0.500
W1K10G-K00D3	5.08	0.200	W1K10P-K00D3	15.24	0.600
W1K10H-K00D3	6.35	0.250			

Additional lengths available on request

NEW NexGen WSMP® Connectors

Specifications

True high frequency performance thru 100 GHz. Footprint optimization available.

Electrical data		Electrical data	
Impedance	50 Ω	Center contact resistance	≤ 6.0 mΩ
Frequency	Next Gen 100 GHz	Outer contact resistance	≤ 2.0 mΩ
Return loss (typical)	≥ 18 dB, DC to 40 GHz ≥ 15 dB, 40 to 70 GHz ≥ 12 dB, 70 to 100 GHz	Test voltage (at sea level)	250 Vrms
Insertion loss	≤ 0.12 x √f(GHz) dB	RF High Potential (at sea level)	150 Vrms @ 5 MHz
Insulation resistance	≥ 3.5 x 10 ⁹ MΩ	RF-leakage (optional)	≥ -80 dB (typical mated pair) @ 30 GHz

Description

WSMP Male, Single Port, SMT Shroud

Part Number

FD: W1S122-400L5
SB: W1S152-400L5

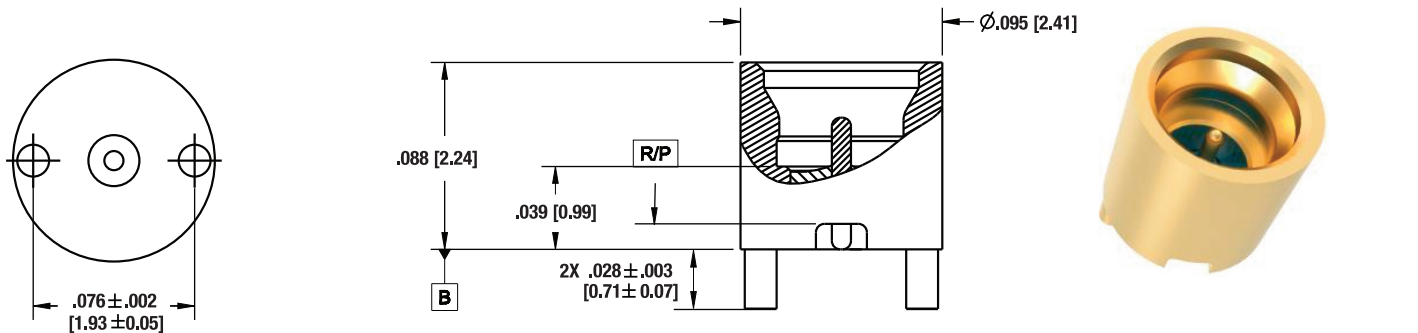

Description

WSMP Male, 1x2 Port SMT Shroud

Part Number

FD: W1S12K-40ML5
SB: W1S15K-40ML5

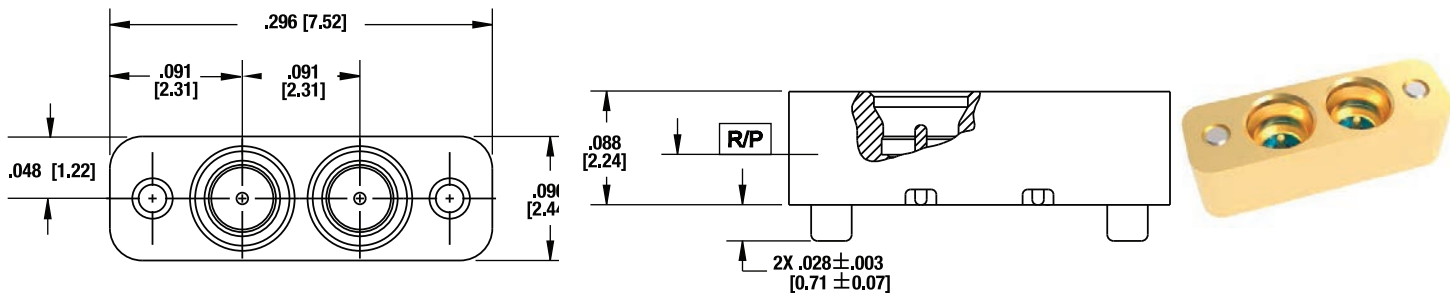

Description

WSMP Male, 1x4 Port, SMT Shroud

Part Number

FD: W1S12L-40ML5
SB: W1S15L-40ML5

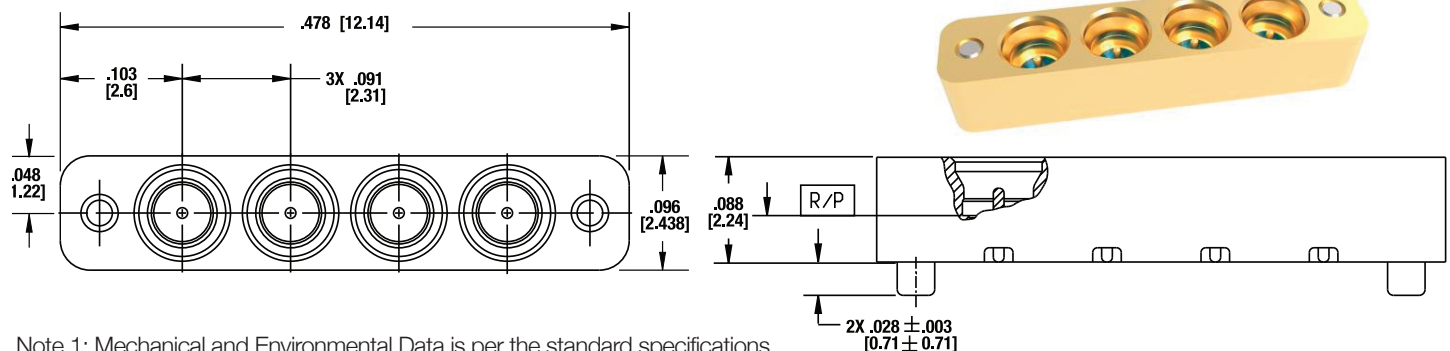

Note 1: Mechanical and Environmental Data is per the standard specifications.

Note 2: Alignment pins are press fit and may be removed at the customer's discretion.

NEW NexGen WSMP® Connectors

Description

WSMP Male, 2x4 Port, SMT Shroud

Part Number

FD: W1S12N-40ML5
SB: W1S15N-40ML5

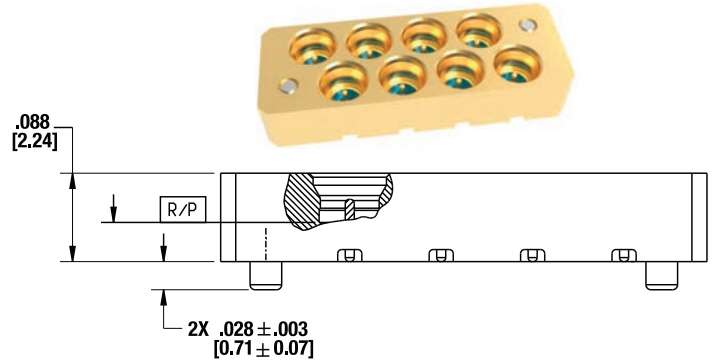
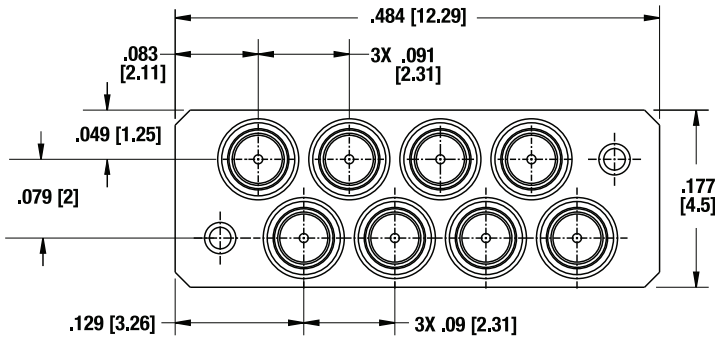

Description

WSMP Male, 1x8 Port, SMT Shroud

Part Number

FD: W1S12M-40ML5
SB: W1S15M-40ML5

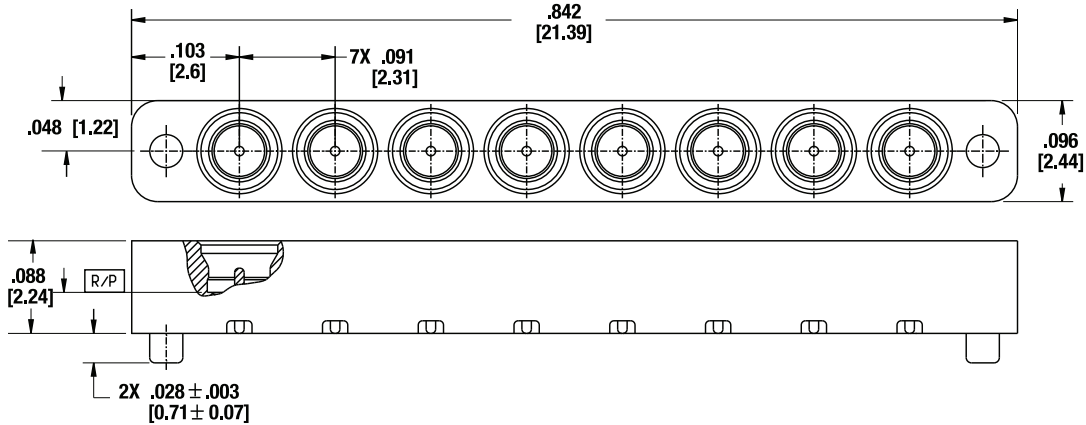

NEW NexGen WSMP® Alignment Covers

Strain reliefs are available that securely hold a cable assembly in place during Test & Measurement or other applications. Alignment covers slide over the WSMP connector.

Description

Single port alignment cover
1x2 port alignment cover
1x4 port alignment cover
1x8 port alignment cover
2x4 port alignment cover

Part Number

W1S152-400/50
W1S15K-40M/50
W1S15L-40M/50
W1S15M-40M/50
W1S15N-40M/50



WSMP® Cable assemblies

Rosenberger's high frequency, flexible cable assemblies incorporating our high performance 1.85mm, 2.92mm, and WSMP connectors.



P/N	Connector 1	Connector 2	Cable	Length	Electrical Specifications (typical)
RPC 1.85 to WSMP:					
70W-08S1-W1K1-00203	1.85mm(m)	WSMP(f)	RTK Flex .047	203mm	DC-70 GHz, R.L.> 12dB @26 GHz, typical
70W-08K1-W1K1-00080	1.85mm(f)	WSMP(f)	RTK Flex .047	80mm	DC-70 GHz, R.L.> 12dB @26 GHz, typical
70W-08S1-W1K2-00203	1.85mm(m)	WSMP(f) r/a	RTK Flex .047	203mm	DC-70 GHz, R.L.> 12dB @26 GHz, typical
RPC 2.92 to WSMP:					
70W-02S1-W1K1-00203	2.92mm(m)	WSMP(f)	RTK Flex .047	203mm	DC-40 GHz, R.L. >12 dB@26 GHz, typical
70W-02K1-W1K1-00080	2.92mm(f)	WSMP(f)	RTK Flex .047	80mm	DC-40 GHz, R.L. >12 dB@26 GHz, typical
70W-02S1-W1K2-00203	2.92mm(m)	WSMP(f), r/a	RTK Flex .047	203mm	DC-40 GHz, R.L. >10 dB@26 GHz, typical
WSMP to WSMP					
70W-W1K1-W1K1-00203	WSMP(F)	WSMP(F)	RTK Flex .047	203mm	DC-70 GHz, R.L. >15 dB@26 GHz, typical
70W-W1K2-W1K2-00203	WSMP(F) r/a	WSMP(F) r/a	RTK Flex .047	203mm	DC-70 GHz, R.L. >14 dB@18 GHz, typical
70W-W1K1-W1K2-00203	WSMP(F)	WSMP(F) r/a	RTK Flex .047	203mm	DC-70 GHz, R.L. >16 dB@18 GHz, typical
RPC 1.0 mm to WSMP					
L70-323-102	WSMP(F)	RPC-100 Plug	RTK Flex .047	102mm	
L70-336-102	WSMP(F)	RPC-100 Jack	RTK Flex .047	102mm	

WSMP 2x8

Description

Straight PCB plug

Part Number

W1S14P-40ML5



Cable Assemblies

Description

2x8 to RPC-2.92 male, 12"
 2x8 to RPC-1.85 male, 12"
 2x8 to 2x8, 12"

Part Number

H70W-W16-Km-00305
 H70W-W16-Vm-00305
 H70W-W16-W16-00305



Next Generation High Performance WSMP® Test Results

Rosenberger's Next Generation High Performance WSMP® connectors offer true, 100 GHz performance in a small, high-density package. The test structure below is used to validate RF measurements to 100GHz.

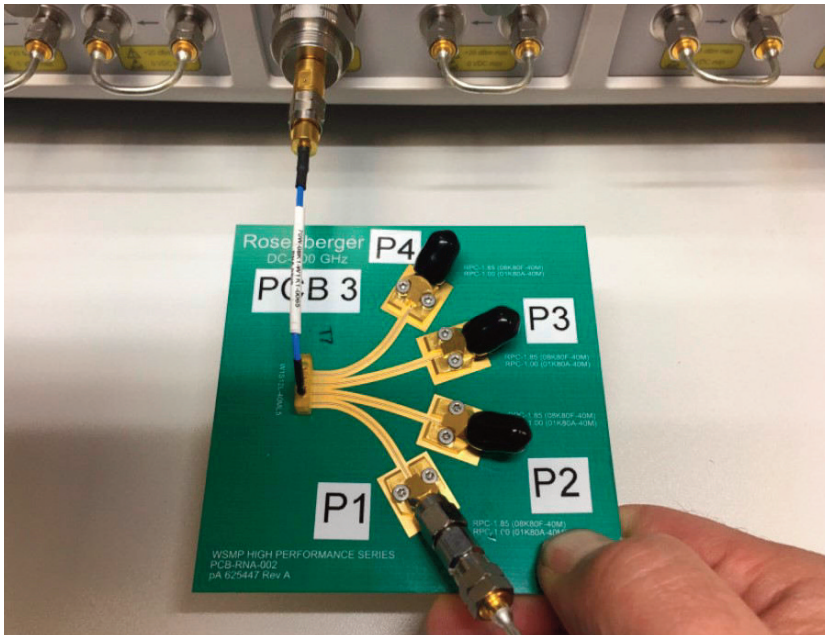

Figure 1

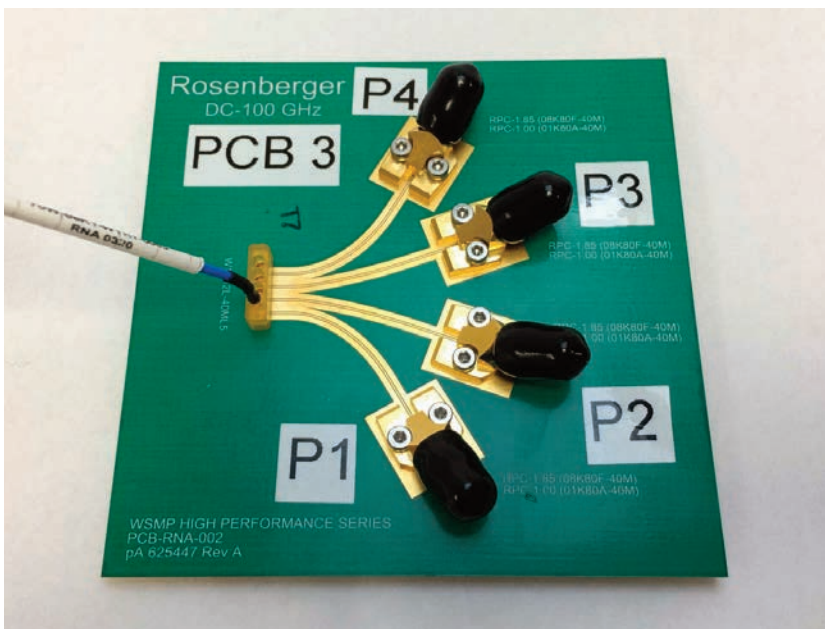

Figure 2

Test Set up:

Pictured to the left, is a detail of the high performance WSMP® test set-up. This is used to take a "full path" measurement from VNA port 1 that includes a full WSMP cable assembly, WSMP mated interfaces, PCB connector and transitions, PCB trace, solderless precision connector, and mated port 2 cable assembly.

Pictured to the left is the basic test setup for gating the WSMP connector performance as it transitions to the PCB. Gate 1 is set in Time Domain at a point along the cable assembly while Gate 2 is set along the PCB trace. The "gated path" reveals the true RF measurements of the WSMP NexGen connector system that includes the mated interface, PCB connector, and PCB transition.

**Also shown is the optional alignment cover to provide mechanical stability during measurements.

Summary of Test results

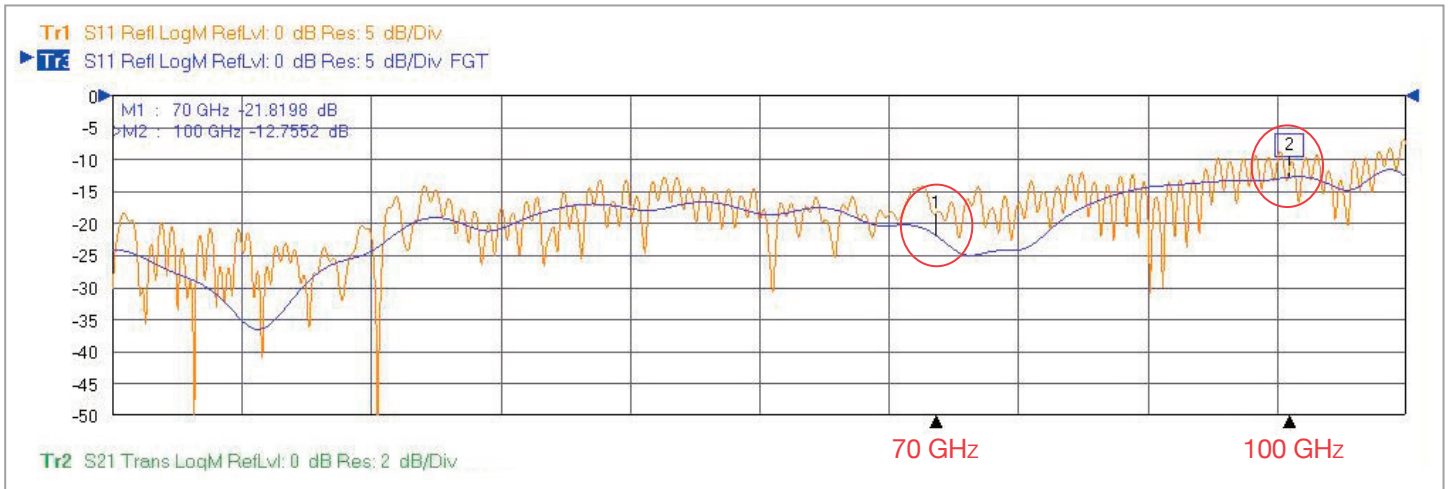

The Vector Network Analyzer's (VNA) output plot (Port 1 through Port 2):

- ♦ The Beige trace is the "full path" from figure 1 (the cable, PCB connector, trace and termination).
- ♦ The Blue trace is the result of the "gated path" from figure 2. The gated measurements demonstrate performance of the NexGen WSMP[®] return loss value exceeding approximately 12dB out to 100GHz.

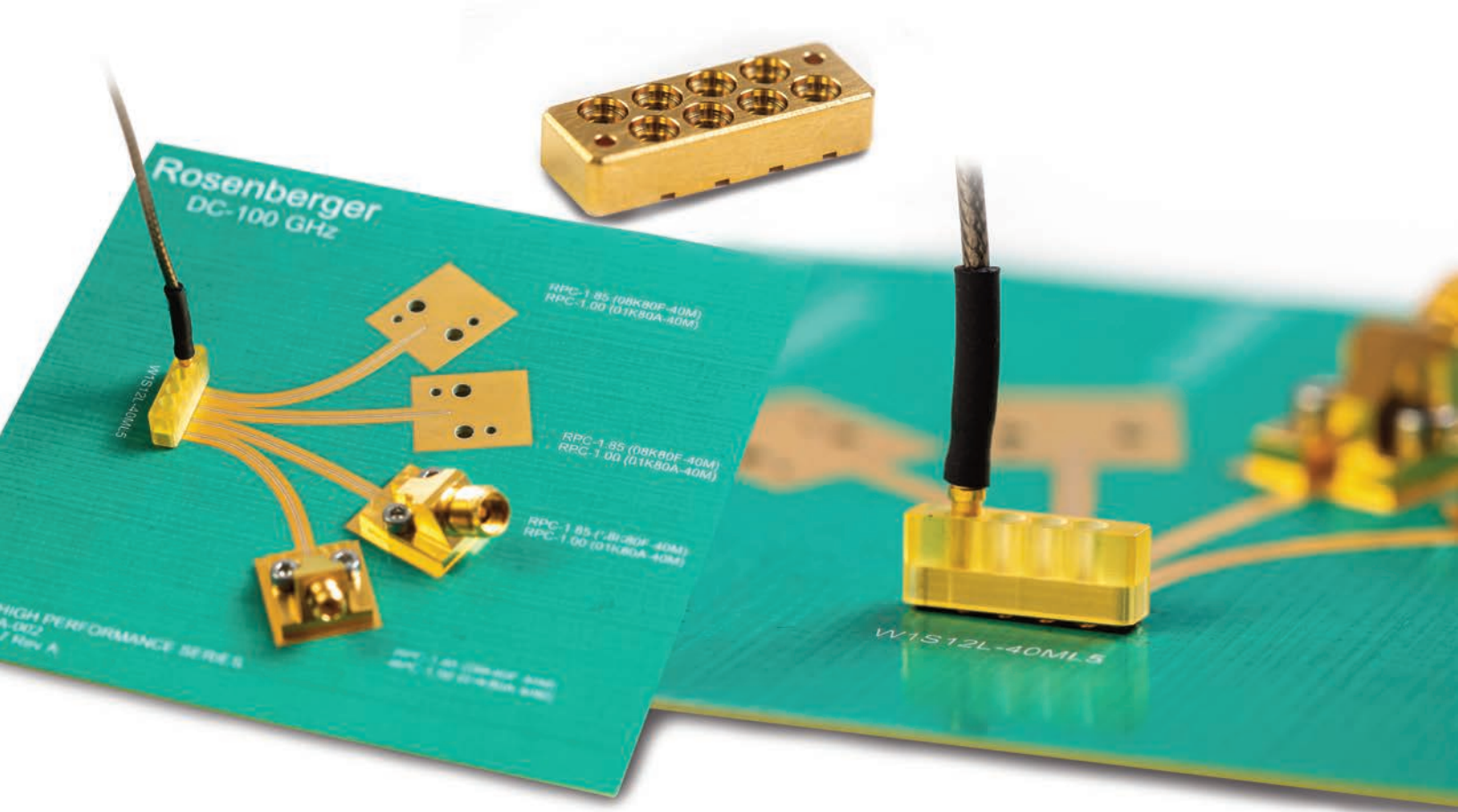

WSMP® and NexGen WSMP® Product Evaluation Boards

Rosenberger offers several product evaluation boards that are available to our customers so that they may evaluate and test the product as they choose. The evaluation boards come in Four configurations: single port NexGen WSMP, 1x4 port NexGen WSMP, 2x8 channel WSMP(standard WSMP) and finally, High Speed OIF style connectors.

EV Board Style	Freq.	Connectors EV Board	Part Number
1x1	70 GHz	2, WSMP NexGen (W1S122-400L5), +2 cable assemblies (WSMP(f) to 1.85mm)	WSMP-Eval-1Ch-70
1x1	100 GHz	2, WSMP NexGen (W1S122-400L5), +2 cable assemblies (WSMP(f) to 1.00mm)	WSMP-Eval-1Ch-100
1x4	70 GHz	1x4 WSMP NexGen + 4, 1.85mm(f) connectors + 2 cable assemblies (WSMP(f) to 1.85mm)	WSMP-Eval-4Ch-70
1x4	100 GHz	1x4 WSMP NexGen + 2, 1.85mm(f) connectors & 2, 1 mm (f) connectors + 2 cable assemblies	WSMP-Eval-4Ch-100
2x8	40 GHz	1, 2x8 (16 channel) WSMP connector + 3, 1.85mm(f) connectors + 3 2.92mm(f) connectors + mating cable assembly (2.92mm)	WSMP-Eval-16Ch-K
2x8	70 GHz	1, 2x8 (16 channel) WSMP connector + 3, 1.85mm(f) connectors + 3 2.92mm(f) connectors + mating cable assembly (1.85mm)	WSMP-Eval-16Ch-V
1x4	110 GHz	1, 4 channel OIF connector. Solderless 1 mm & 1.85 mm	WSMP-OIF-Eval -4

Notes: NexGen WSMP Evaluation boards include plastic strain relief.

Connectors sold separately.

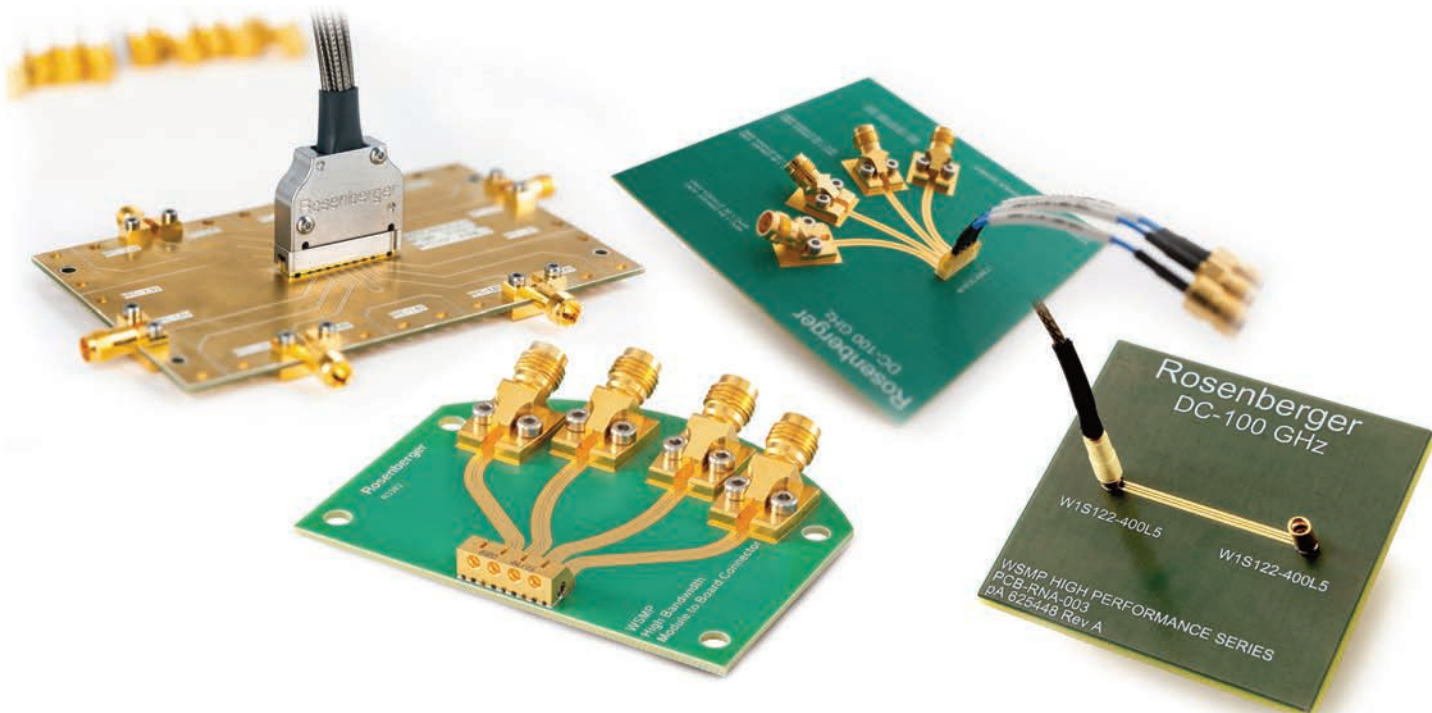

Accessories

Between Series Test Adapters

Description

WSMP Male Full Detent to
RPC-2.92 Female Adapter
RPC-1.85 Female Adapter
RPC-2.4 Male Adapter
RPC-2.4 Female Adapter
RPC-1.00 Male Adapter

Part Number

W1S102-K00S3 to 40 GHz
W1S108-K00S3 to 65 GHz
W1S109-S00S3 to 50 GHz
W1S109-K00S3 to 50 GHz
W1S101-S00D3 to 100 GHz

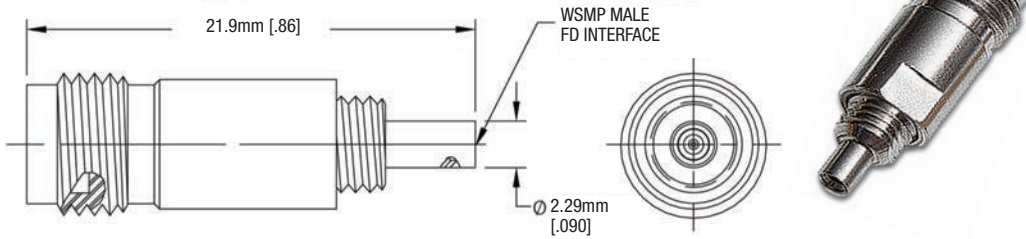

Description

WSMP Female to
RPC-2.92 Female Adapter
RPC-1.85 Female Adapter
RPC-2.4 Female Adapter
RPC-1.00 Male Adapter

Part Number

W1K102-K00D3 to 40 GHz
W1K108-K00D3 to 67 GHz
W1K109-K00D3 to 50 GHz
W1K101-K00D3 to 50 GHz

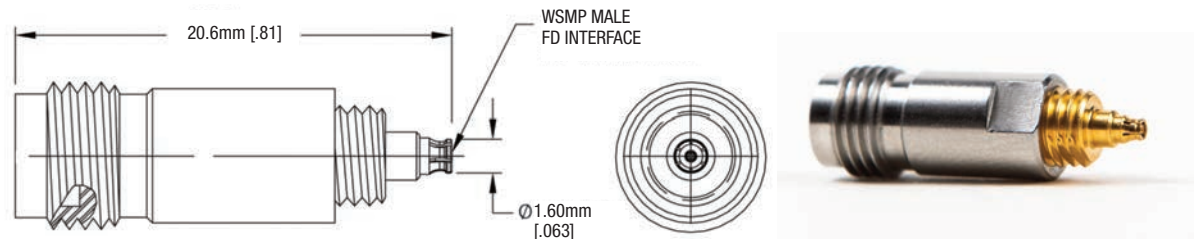

Tools. Custom for your needs

Description

WSMP Cable Connector
Prybar Extraction Tool

Part Number
W1W001-000



Description

WSMP Right Angle
Prybar Extraction Tool

Part Number
W1W005-000



Description

WSMP Bullet Insertion/
Extraction Tool

Part Number
W1W002-000

