

ebm-papst Mulfingen GmbH & Co. KG

Bachmühle 2 · D-74673 Mulfingen

Phone +49 7938 81-0

Fax +49 7938 81-110

info1@de.ebmpapst.com

www.ebmpapst.com

Limited partnership · Headquarters Mulfingen

County court Stuttgart · HRA 590344

General partner: Elektrobau Mulfingen GmbH · Headquarters Mulfingen

County court Stuttgart · HRB 590142

Nominal data

Type	W2G110-AK43-31	
Motor	M2G045-BA	
Nominal voltage	VDC	24
Nominal voltage range	VDC	16 .. 28
Type of data definition		fa
Speed	min ⁻¹	4400
Power input	W	15
Max. back pressure	Pa	100
Min. ambient temperature	°C	- 25
Max. ambient temperature	°C	+72

ml = max. load · me = max. efficiency · fa = running at free air · cs = customer specs · cu = customer unit
Subject to alterations



Technical features

Mass	0.49 kg
Size	110 mm
Surface of rotor	Coated in black
Material of blades	Sheet steel, coated in black
Material of wall ring	Die-cast aluminium, coated in black
Number of blades	5
Direction of air flow	"A"
Direction of rotation	Counter-clockwise, seen on rotor
Type of protection	IP 22
Insulation class	"B"
Max. permissible ambient motor temp. (transp./ storage)	+ 80 °C
Min. permissible ambient motor temp. (transp./storage)	- 25 °C
Mounting position	Any
Condensate discharge holes	None
Operation mode	S1
Motor bearing	Ball bearing
Electrical leads	With plug
Motor protection	Reverse polarity and locked-rotor protection
Product conforming to standard	EN 60950-1
Approval	CSA C22.2 Nr.113; UL 507

Product drawing

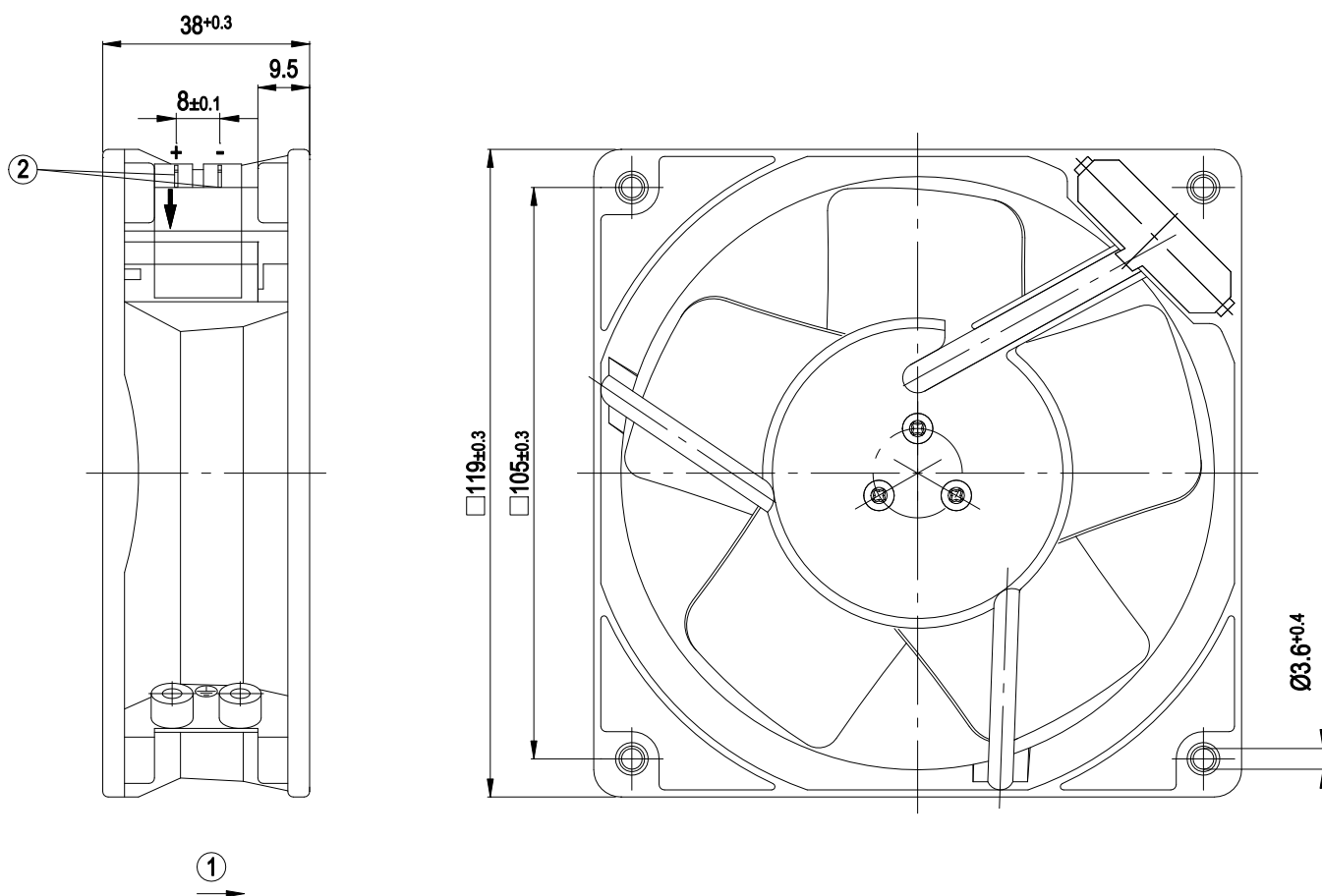

1	Direction of air flow "A"
2	2 x flat plugs 2.8x0.5 (AMP no. 170058-2)

Connection screen

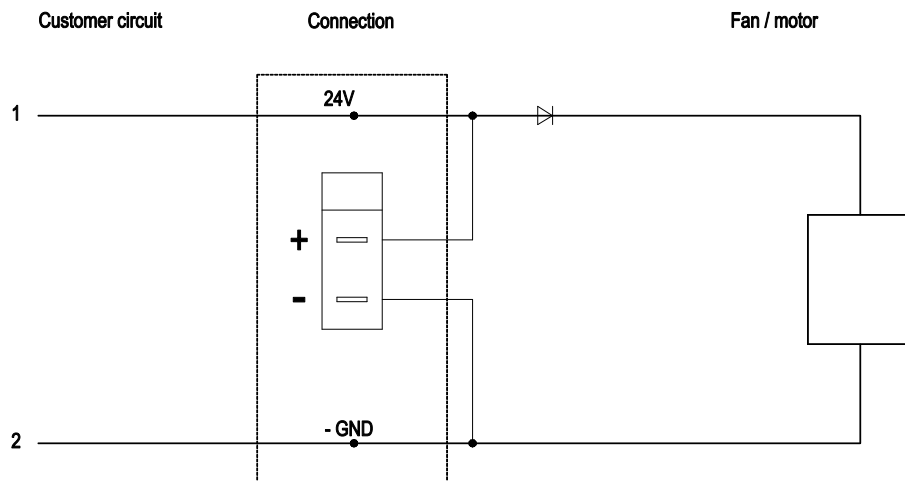

Line	No.	Signal	Colour	Function / assignment
1	1	UN +24V	red	Power supply +24 V/voltage range refer to rating plate, residual ripple $\pm 3.5\%$
1	2	GND	blue	Reference mass