

REVISIONS			
REV	DESCRIPTION	DATE	APPV

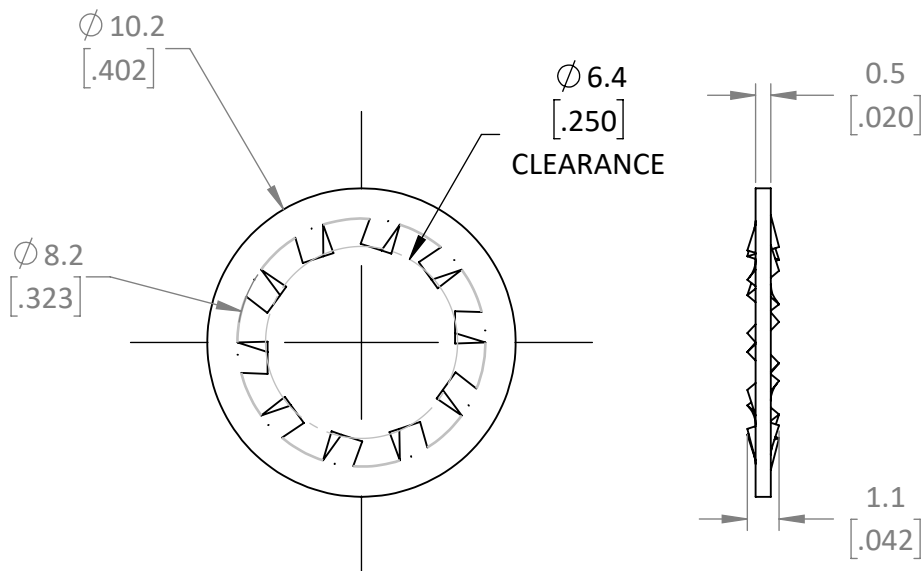

NOTES: (UNLESS OTHERWISE SPECIFIED)

1. ALL DIMENSIONS ARE IN MILLIMETERS [in].
2. DIMENSIONS APPLY AFTER FINISHING.
3. MANUFACTURE TO BE COMPLIANT WITH EU RoHS DIRECTIVE, USE MATERIALS THAT DO NOT CONTAIN REACH SUBSTANCES OF VERY HIGH CONCERN >1000ppm, AND USE DRC CONFLICT-FREE SOURCED MATERIALS.
4. SAFETY BREAK ALL SHARP CORNERS AND EDGES .02 MAXIMUM.

FINISH VARIATIONS	
FINISH	PART NUMBER
NICKEL	WS-SMA-N
GOLD	WS-SMA-G

WARNING: THIS DRAWING CONTAINS PROPRIETARY INFORMATION THAT IS THE SOLE PROPERTY OF LINX TECHNOLOGIES, AND SHALL BE TREATED AS SUCH. NO DISCLOSURE OR REPRODUCTION OF THIS DOCUMENT IS PERMITTED, IN WHOLE OR IN PART, WITHOUT THE EXPRESS WRITTEN PERMISSION OF LINX TECHNOLOGIES OR ITS DESIGNATED AGENTS.



159 ORT LANE
MERLIN, OR 97532

TITLE:
WASH LOC SMA 1/4DIA VAR

MATERIAL: Brass -G Phosphor Bronze -N	INTERPRET DIMENSIONS AND TOLERANCES PER ASME Y14.5. .X ±2.0 .XX ±1.00 .XXX ±.500	ANGLES: ±1° SURFACE: $\sqrt{\text{32}}$	PROJECTION: 	SIZE A	DWG. NO. C-WS-SMA-X	REV A
FINISH: -N [NICKEL] -G [GOLD]	DRAWN: JHAGER ENGR: S.HOGAN	DT: 8/3/20 DT:	SCALE: 4:1	DO NOT SCALE DRAWING	SHEET 1 OF 1	