

Time-of-Flight ranging sensor with multi target detection expansion board based on VL53L3CX for STM32 Nucleo

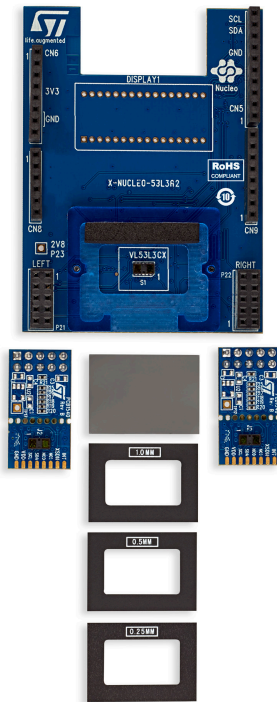

Features

- VL53L3CX Time-of-Flight (ToF) ranging sensor with multi target detection
- Accurate absolute ranging distance, independent of the reflectance of the target
- 0.25, 0.5, and 1 mm spacers to simulate air gaps
- Two different cover windows
- Two VL53L3CX breakout boards
- Compatible with STM32 Nucleo board family
- Equipped with Arduino™ UNO R3 connector
- RoHS compliant
- Full system software (SW) supplied, including code examples and graphical user interface. All this can be downloaded from the VL53L3CX product page on st.com.

Description

The X-NUCLEO-53L3A2 is an expansion board for the NUCLEO-F401RE development board. It provides a complete evaluation kit allowing anyone to learn, evaluate, and develop their applications using the VL53L3CX, ranging sensor with multi target detection..

The X-NUCLEO-53L3A2 expansion board is delivered with a cover glass holder in which three different spacers of 0.25, 0.5, and 1 mm height can be fitted below the cover glass to simulate various air gaps.

Two VL53L3CX breakout boards can be connected using two 10-pin connectors.

The X-NUCLEO-53L3A2 expansion board is compatible with the STM32 nucleo board family, and with the Arduino UNO R3 connector layout.

Several ST expansion boards can be superposed through the Arduino connectors which allows, for example, the development of VL53L3CX applications with Bluetooth or Wi-Fi interfaces.

Order code	Description
X-NUCLEO-53L3A2	Expansion board for STM32 nucleo board family

1 Block diagram

The figure below describes the X-NUCLEO-53L3A2 expansion board features

Figure 1. X-NUCLEO-53L3A2 circuit diagram

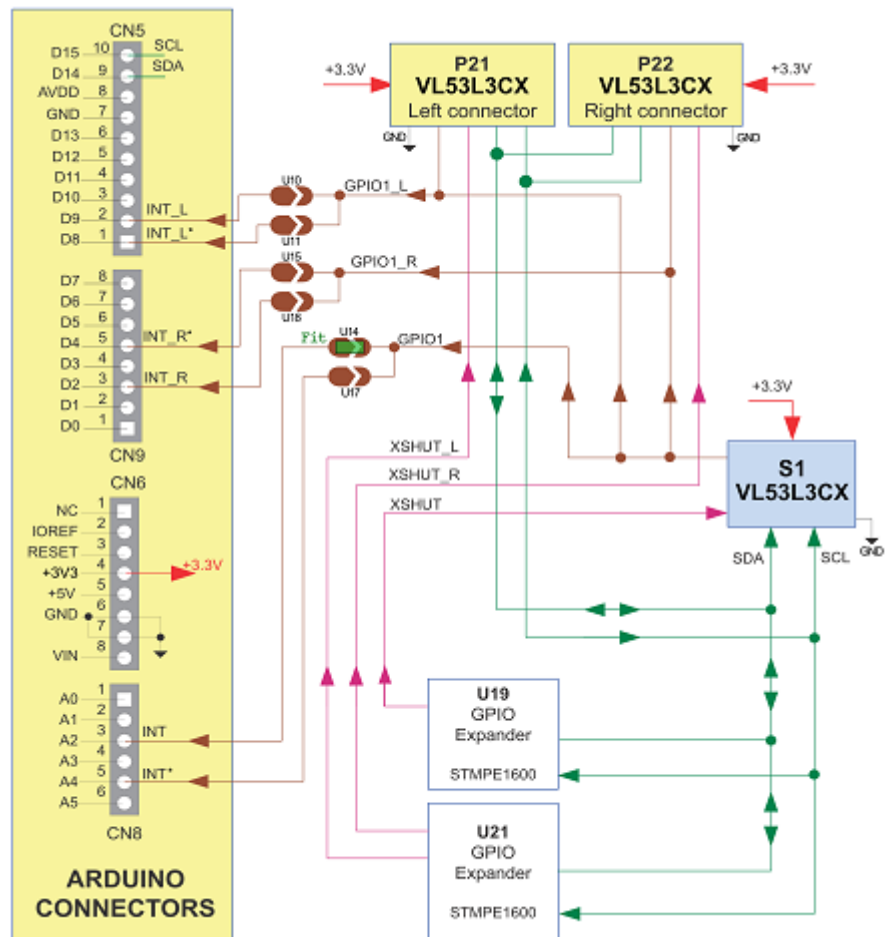

2 Optional VL53L3CX breakout boards

The VL53L3CX breakout boards can be directly plugged onto the VL53L3CX expansion board through two 10-pin connectors or they can be connected to the board through flying leads (see figure below).

When connected through flying leads, developers should break off the mini PCB from the breakout board, and use only the “VL53L3CX mini PCB” which is smaller and integrates more easily into customers devices

Figure 2. Connections of VL53L3CX breakout boards

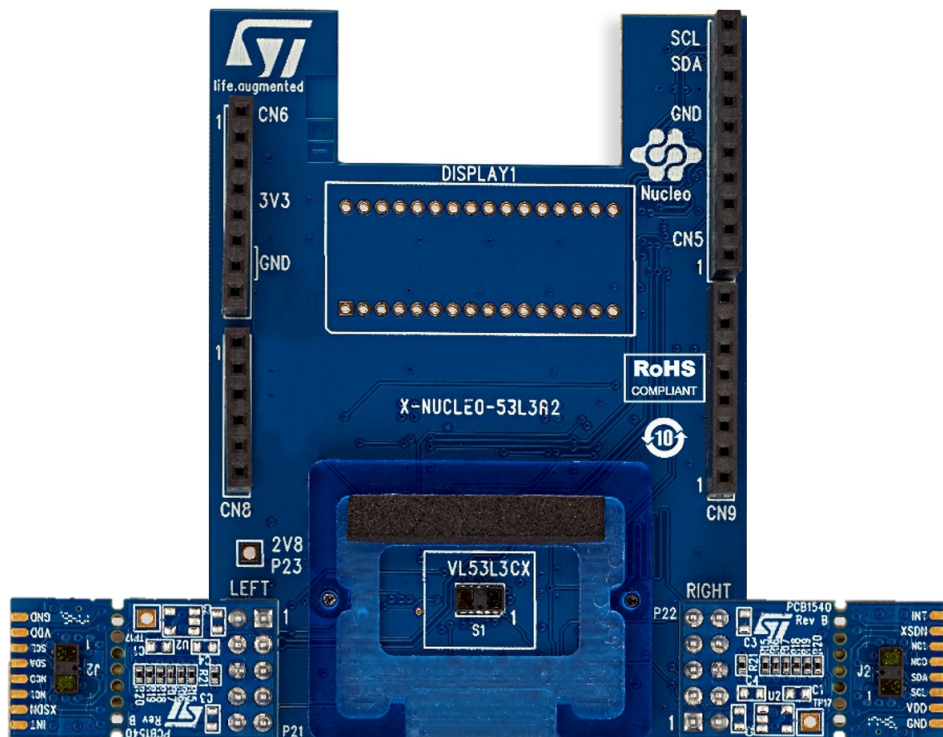

3 Laser safety considerations

The VL53L3CX contains a laser emitter and corresponding drive circuitry. The laser output is designed to remain within Class 1 laser safety limits under all reasonable foreseeable conditions, including single faults, in compliance with the IEC 60825-1:2014 (third edition). The laser output remains within Class 1 limits as long as the STMicroelectronics recommended device settings are used and the operating conditions specified in the datasheet are respected. The laser output power must not be increased and no optics should be used with the intention of focusing the laser beam.

Figure 3. Class 1 laser product label



4 Package information

In order to meet environmental requirements, ST offers these devices in different grades of **ECOPACK** packages, depending on their level of environmental compliance. ECOPACK specifications, grade definitions and product status are available at: www.st.com. ECOPACK is an ST trademark.

Revision history

Table 1. Document revision history

Date	Version	Changes
18-May-2020	1	Initial release
23-Apr-2021	2	Updated Figure 1. X-NUCLEO-53L3A2 circuit diagram.