

Proximity and ambient light sensor expansion board based on VL6180X for STM32 Nucleo

Data brief

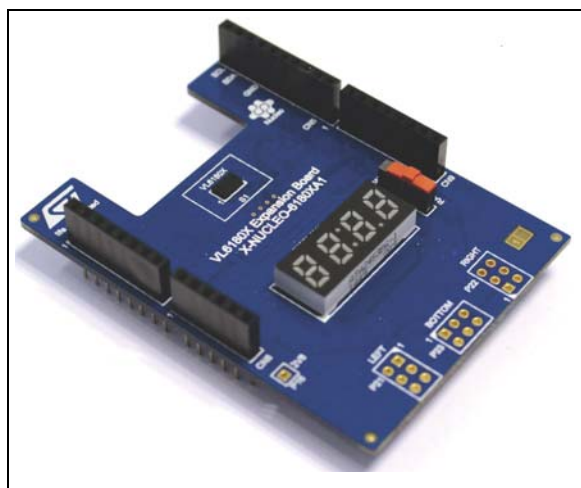

- Basic gesture recognition application can be developed with one or multiple VL6180X modules.
- Compatible with STM32 Nucleo board family.
- Equipped with Arduino™ UNO R3 connector.
- RoHS compliant.
- Full system SW supplied, download from www.st.com/vl6180x.

Description

The X-NUCLEO-6180XA1 expansion board features the VL6180X proximity, gesture and ALS sensor, based on ST's FlightSense™, Time-of-Flight technology.

It is an evaluation board that provides an introduction to the proximity, ranging and light sensing capabilities of the VL6180X module. It is compatible with the STM32 Nucleo board family, and with the Arduino UNO R3 connector layout.

Several ST expansion boards can be superposed through the Arduino connectors, which allows for example to develop VL6180X applications with Bluetooth or WiFi interface.

Features

- VL6180X proximity, gesture and ambient light sensing (ALS) module.
- Slider switch controlling 2 functions:
 - Ranging measurement, beyond 400mm.
 - Ambient light sensing, up to 100 kLux^(a).
- 4-digit display, displaying either the distance of a target from the proximity sensor, or the lux value from the ambient light sensing (ALS).
- Excellent ranging accuracy, independent of the reflectance of the target.
- In order to easily integrate multiple VL6180X's into customer devices, up to 3 external satellite VL6180X boards can be connected to the expansion board.
- Satellite boards can be ordered on <http://www.st.com/web/en/catalog/tools/PF261466> under the reference VL6180X-SATEL.

Table 1. Ordering information

Order code	Description
X-NUCLEO-6180XA1	VL6180X expansion board for STM32 Nucleo board family.

a. VL6180X detects up to 100kLux but since the display is a 4 digits only, maximum displayed value is limited to 9999 Lux.

1 Block diagram

Figure 1 describes VL6180X expansion board features.

Figure 1. VL6180X expansion board block diagram

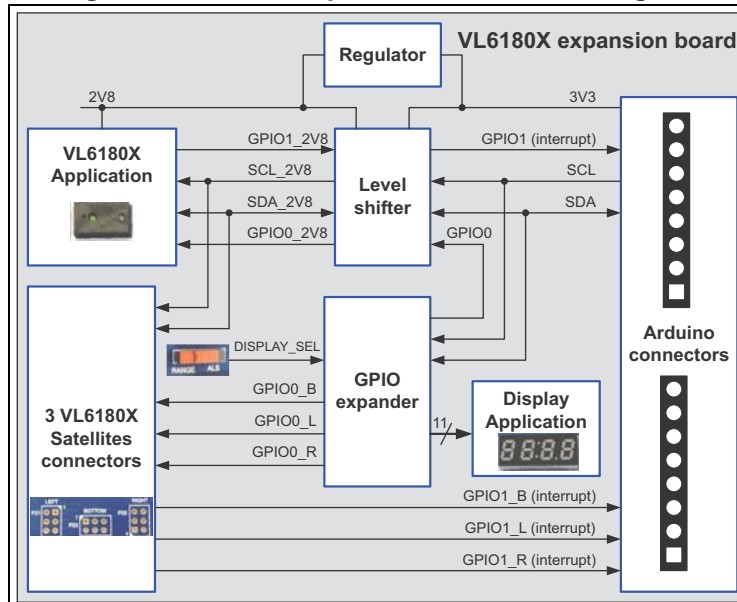

2 Laser consideration

The VL6180X contains a laser emitter and corresponding drive circuitry. The laser output is designed to remain within Class 1 laser safety limits under all reasonably foreseeable conditions including single faults in compliance with IEC 60825-1:2007. The laser output will remain within Class 1 limits as long as the STMicroelectronics recommended device settings are used and the operating conditions specified in the datasheet are respected. The laser output power must not be increased by any means and no optics should be used with the intention of focusing the laser beam.

Figure 2. Class 1 laser product label



Compliance

Complies with 21 CFR 1040.10 and 1040.11 except for deviations pursuant to Laser Notice No.50, dated June 24, 2007.

3 ECOPACK®

In order to meet environmental requirements, ST offers these devices in different grades of ECOPACK® packages, depending on their level of environmental compliance. ECOPACK® specifications, grade definitions and product status are available at: www.st.com. ECOPACK® is an ST trademark.

4 Revision history

Table 2. Document revision history

Date	Revision	Changes
17-Feb-2015	1	Initial release.
11-Mar-2015	2	Title modification
26-May-2015	3	Add Chapter 2: Laser consideration
02-Jun-2015	4	Update Web link to order satellite boards on first page