

## NFC card reader expansion board based on ST25R3916B for STM32 and STM8 Nucleos

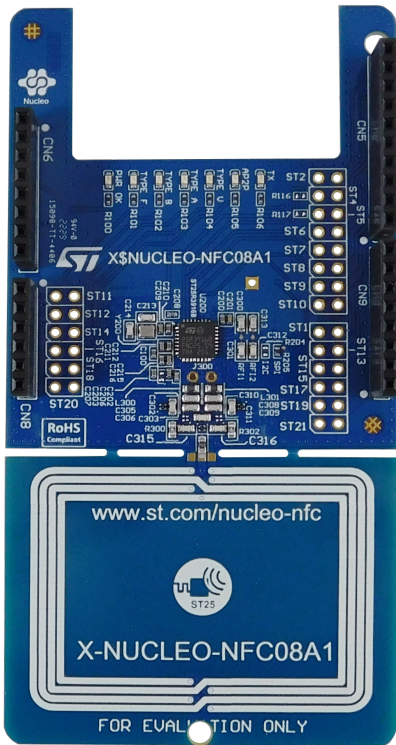

### Features

- On-board NFC card reader IC: **ST25R3916B**
- 47 mm x 34 mm, four turns, 13.56 MHz inductive antenna etched on PCB and associated tuning circuit
- Six general-purpose LEDs
- ISO 18092 passive and active initiator, ISO 18092 passive, and active target
- NFC-A and NFC-F card emulation
- ISO 14443A and ISO14443B
- ISO 15693
- FeliCa™
- Up to 1.7 W output power with differential antenna
- Possibility of driving two antennas in single-ended configuration
- Inductive wake-up
- Automatic antenna-tuning system
- Transparent and stream modes to implement MIFARE™ classic compliant or other custom protocols
- Equipped with Arduino UNO R3 connector
- Free comprehensive development firmware library compatible with **STM32Cube** and samples for **ST25R3916B**
- Scalable solution for multiple board cascade
- FCC certified
- RoHS and WEEE compliant

### Description

The **X-NUCLEO-NFC08A1** NFC card reader expansion board is based on the **ST25R3916B** device.

The expansion board is configured to support ISO14443A/B, ISO15693, FeliCa™, and AP2P communication.

The **ST25R3916B** manages frame coding and decoding in reader mode for standard applications, such as NFC, proximity, and vicinity HF RFID standards. It supports ISO/IEC 14443 type A and B, ISO/IEC 15693 (single subcarrier only) and ISO/IEC 18092 communication protocols as well as the detection, reading and writing of NFC forum type 1, 2, 3, 4, and 5 tags.

The on-board low-power capacitive sensor performs ultra-low power wake-up without switching the reader field on and traditional inductive wake-up to select amplitude or phase measurement.

The automatic antenna tuning (AAT) technology enables operation close to metallic parts and/or in changing environments.

Product summary	
NFC card reader expansion board based on ST25R3916B for STM32 and STM8 Nucleos	<b>X-NUCLEO-NFC08A1</b>
High-performance NFC universal device and EMVCo reader	<b>ST25R3916B-AQWT</b>
High-performance HF reader/NFC initiator IC software expansion for STM32Cube	<b>X-CUBE-NFC6</b>
Applications	<b>Wireless Connectivity</b>

# 1 Schematic diagrams

Figure 1. X-NUCLEO-NFC08A1 circuit schematic (1 of 3)

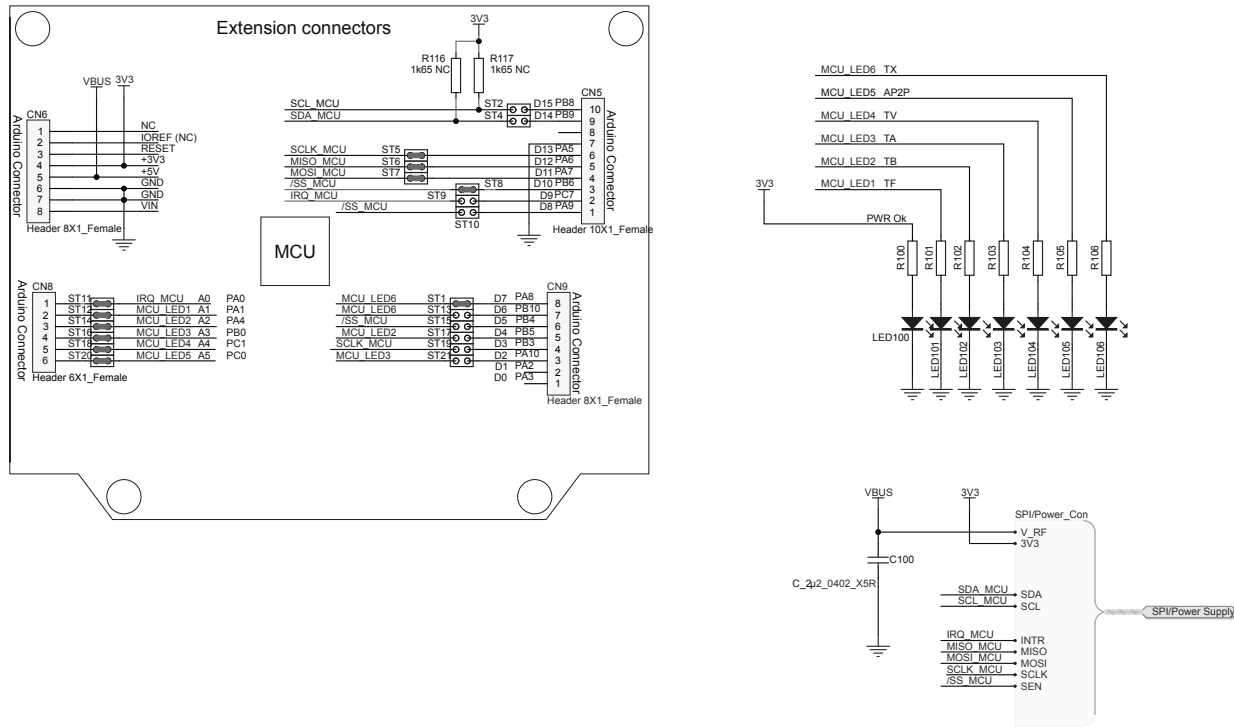

Figure 2. X-NUCLEO-NFC08A1 circuit schematic (2 of 3)

ST25R3916 NFC Initiator / HF Reader

Controller Interface

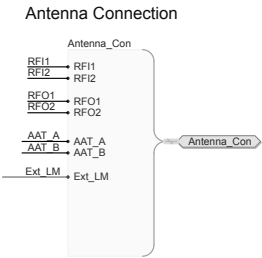
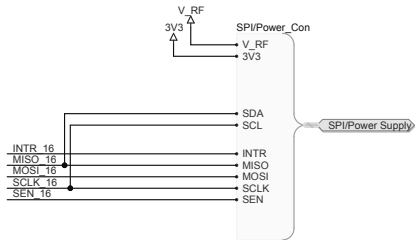
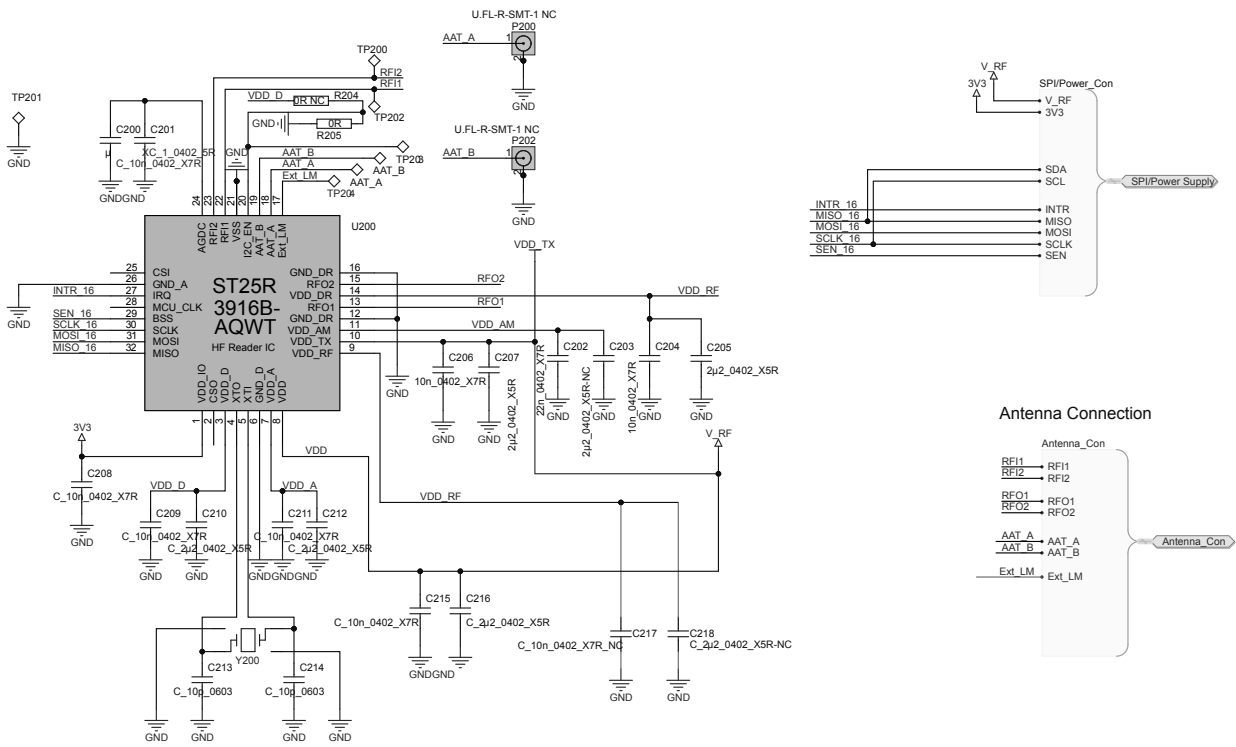
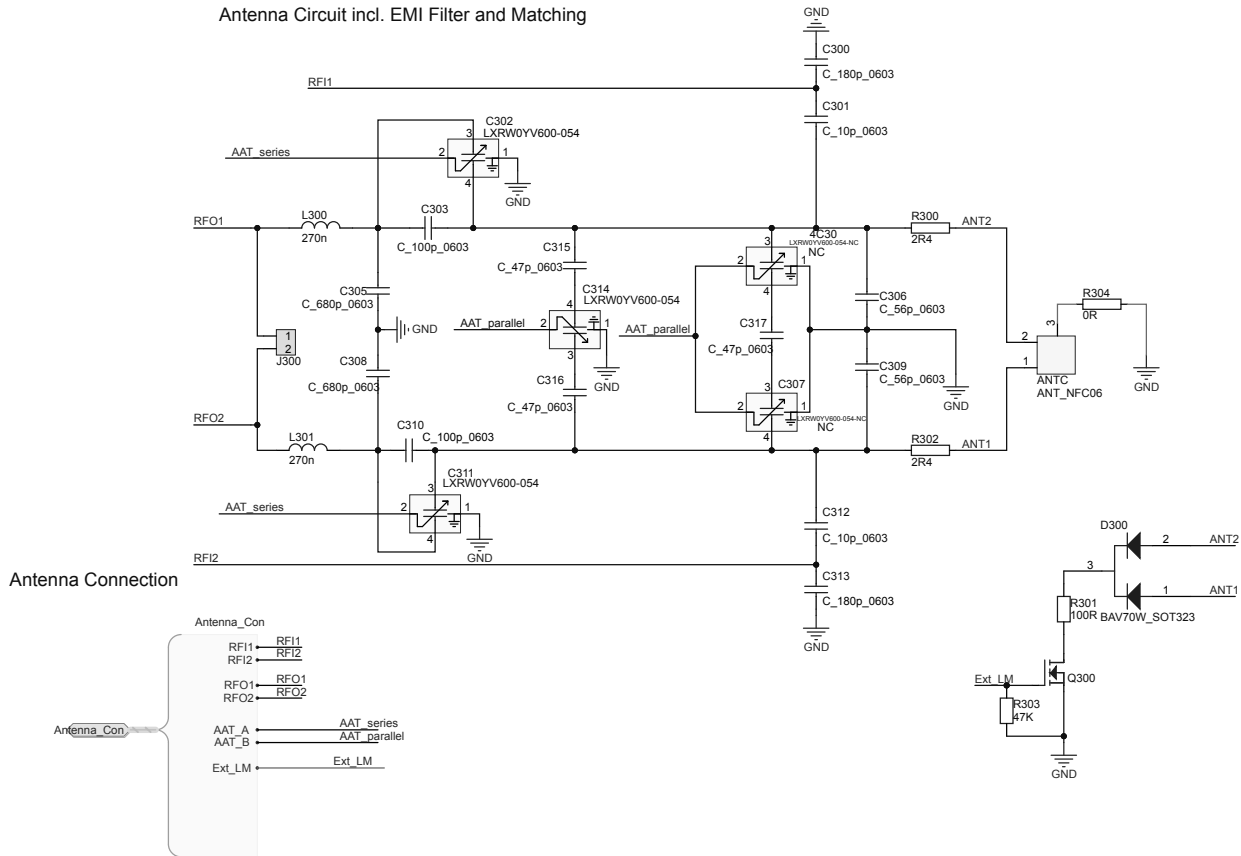

Figure 3. X-NUCLEO-NFC08A1 circuit schematic (3 of 3)

Antenna Circuit incl. EMI Filter and Matching



## Revision history

**Table 1. Document revision history**

Date	Revision	Changes
14-Sep-2022	1	Initial release.