

Industrial digital output expansion board based on ISO8200AQ for STM32 Nucleo

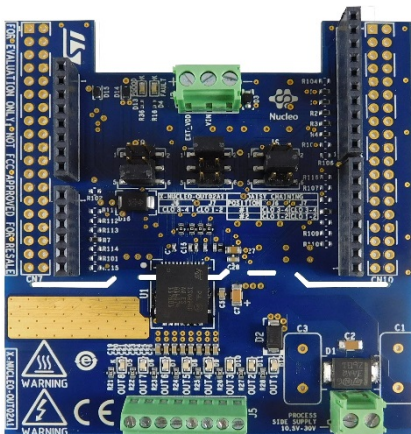

Features

- Based on the [ISO8200AQ](#) whose main characteristics are:
 - Embedded 4kV galvanic isolation
 - Radio frequency communication between the logic and process sides for maximum noise immunity
 - Very low power dissipation ($R_{ON(MAX)} = 220\text{ m}\Omega$)
 - Fast decay for inductive loads
 - 20 MHz SPI I/F on logic side
 - V_{CC} power good diagnostics
 - Overload and overheating protections with thermal shutdown and diagnostics
 - QFN-32L (9x11x1 mm) package
- 10.5 to 33 V operating voltage range
- Green LED (x8) for output on/off status
- Red LED for process supply power good fault
- Red LED for overload and overheating
- Supply reverse polarity protection
- EMC compliance according to IEC61000-4-2, IEC61000-4-3, IEC61000-4-5
- Compatible with [STM32 Nucleo](#) boards
- Equipped with [Arduino™ UNO R3](#) connectors
- CE certified
- RoHS and China RoHS compliant
- WEEE compliant

Description

The [X-NUCLEO-OUT02A1](#) industrial digital output expansion board for [STM32 Nucleo](#) is based on the [ISO8200AQ](#) galvanic isolated octal high-side smart power solid state-relay.

It provides an affordable and easy-to-use solution for the development of 8-channel digital output modules, letting you easily evaluate the [ISO8200AQ](#) communication and industrial load driving features.

The [X-NUCLEO-OUT02A1](#) can be connected to a [NUCLEO-F401RE](#) or [NUCLEO-F334R8](#) development board via [Arduino™ UNO R3](#) connectors.

You can also evaluate the 16-channel digital output modules by connecting two [X-NUCLEO-OUT02A1](#) expansion boards and activating the daisy chaining feature.

The [X-NUCLEO-OUT02A1](#) interfaces with the STM32 controller via SPI and GPIO pins and is compatible with the [Arduino™ UNO R3](#) (default configuration) and ST morpho (optional, not mounted) connectors.

Industrial PLC functionality with 8 inputs and 16 outputs can be added with the [X-NUCLEO-PLC01A1](#) expansion board.

Product summary	
Industrial digital output expansion board based on ISO8200AQ for STM32 Nucleo	X-NUCLEO-OUT02A1
Industrial input/output expansion board based on VNI8200XP and CLT01-38SQ7 for STM32 Nucleo	X-NUCLEO-PLC01A1
Galvanic isolated octal high-side smart power solid state-relay	ISO8200AQ
STM32 Nucleo-64 development board with STM32F401RE/ STM32F334R8 MCU	NUCLEO-F401RE/ NUCLEO-F334R8

1 Schematic diagrams

Figure 1. X-NUCLEO-OUT02A1 circuit schematic (1 of 2)

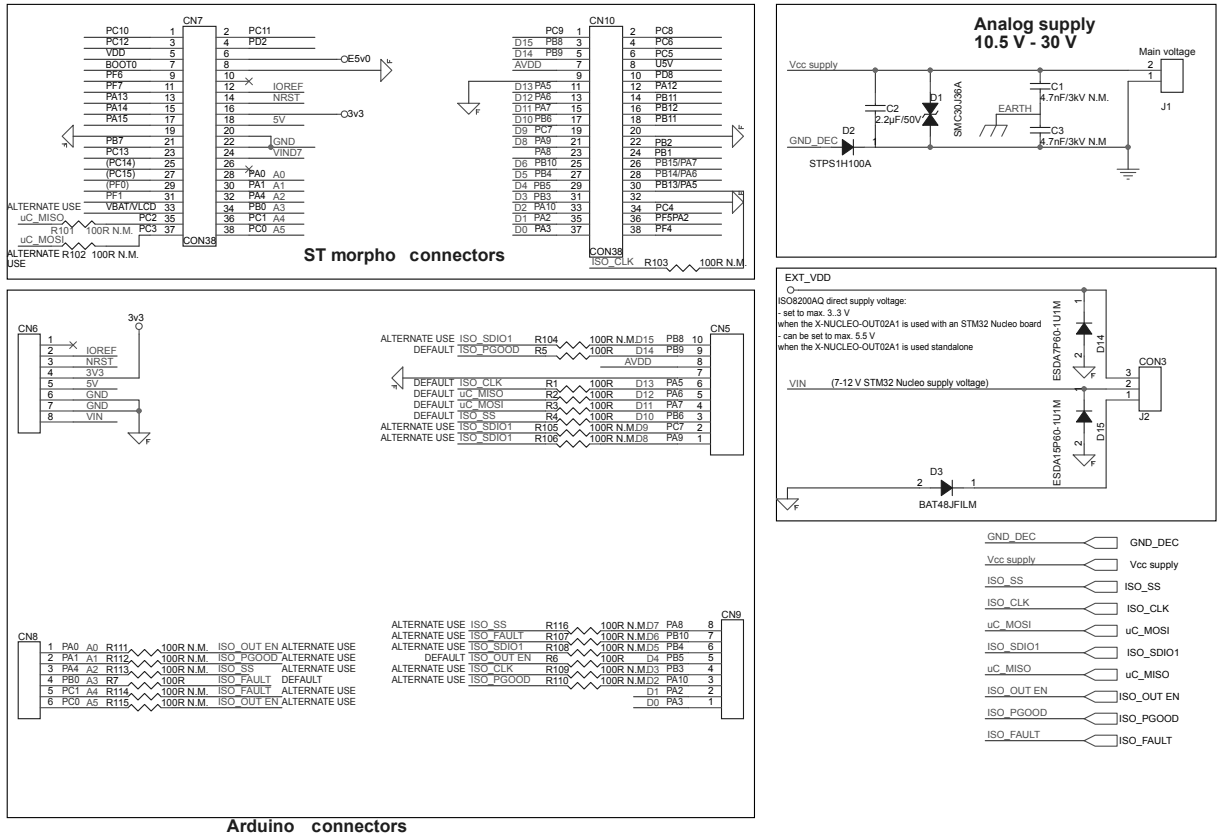
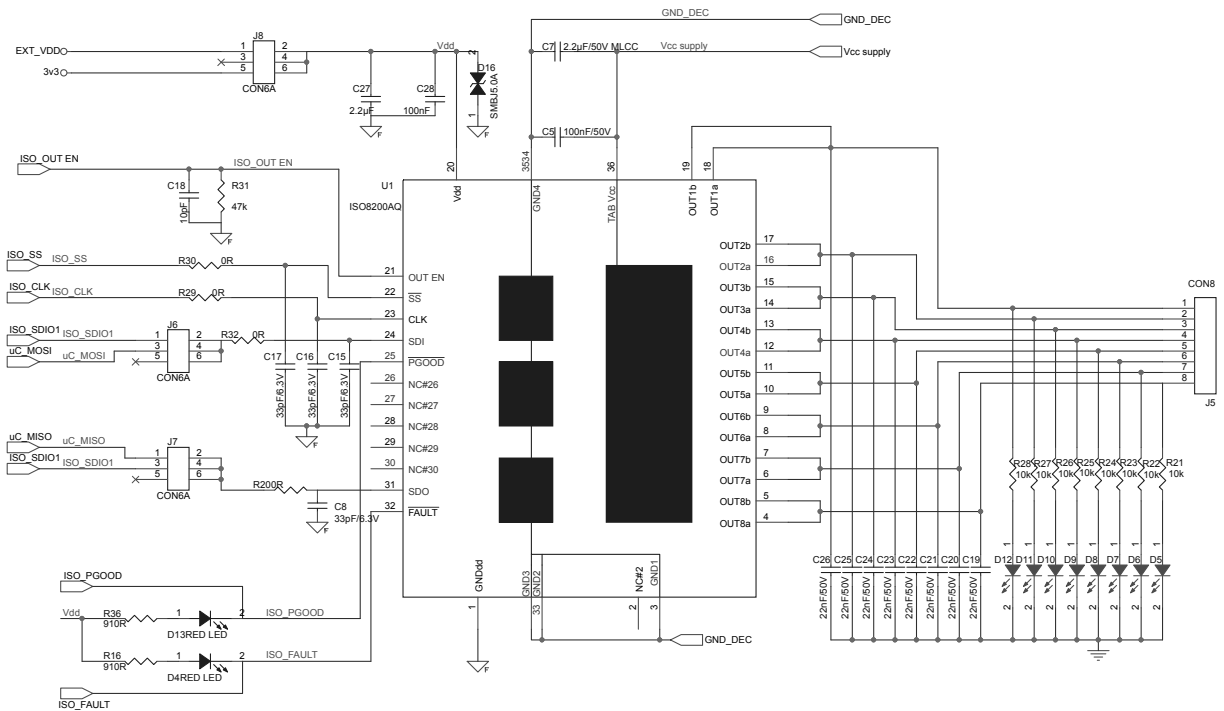

Figure 2. X-NUCLEO-OUT02A1 circuit schematic (2 of 2)



Revision history

Table 1. Document revision history

Date	Version	Changes
06-Nov-2018	1	Initial release.
20-Nov-2018	2	Updated cover page description.