

# Industrial digital output expansion board based on IPS1025H-32 for STM32 Nucleo

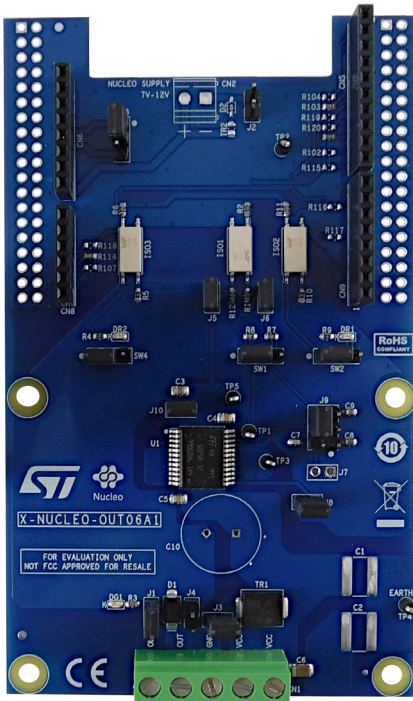

## Features

- Based on **IPS1025H-32** single high-side switch, which features:
  - Operating range up to 60 V
  - Low power dissipation ( $R_{ON(MAX)} = 25\text{ m}\Omega$ )
  - Fast decay for inductive loads
  - Smart driving of capacitive load
  - Under-voltage lock-out
  - Overload and over-temperature protection
  - PSSO24 package
- Application board operating range: 8 to 33 V/0 to 5.7 A
- Extended voltage operating range (J3 open) up to 60 V
- Green LED for output on/off status
- Red LEDs for diagnostics (overload and overheating)
- 5 kV galvanic isolation
- Supply rail reverse polarity protection
- EMC compliance with IEC61000-4-2, IEC61000-4-3, IEC61000-4-4, IEC61000-4-5, IEC61000-4-8
- Compatible with **STM32 Nucleo** development boards
- Equipped with Arduino UNO R3 connectors
- CE certified:
  - EN 55032:2015 + A1:2020
  - EN 55035:2017 + A11:2020
- RoHS and China RoHS compliant

## Description

The **X-NUCLEO-OUT06A1** industrial digital output expansion board for **STM32 Nucleo** provides a powerful and flexible environment for the evaluation of the driving and diagnostic capabilities of the **IPS1025H-32** single high-side smart power solid state relay, in a digital output module connected to 5.7 A industrial loads.

The **X-NUCLEO-OUT06A1** interfaces with the microcontroller on the **STM32 Nucleo** via 5 kV optocouplers driven by GPIO pins and Arduino UNO R3 connectors.

The expansion board can be connected to either a **NUCLEO-F401RE** or **NUCLEO-G431RB** development board.

It is also possible to evaluate a system composed by up to four stacked **X-NUCLEO-OUT06A1** expansion boards.

As an example, a system with four **X-NUCLEO-OUT06A1** expansion boards allows you to evaluate a quad channel digital output module.

Product summary	
Industrial digital output expansion board based on IPS1025H-32 for STM32 Nucleo	X-NUCLEO-OUT06A1
Industrial digital output software expansion for STM32Cube	X-CUBE-OUT5
Single high-side smart power solid state-relay	IPS1025H-32
Applications	Programmable Logic Controllers

# 1 Schematic diagrams

Figure 1. X-NUCLEO-OUT06A1 circuit schematic (1 of 2)

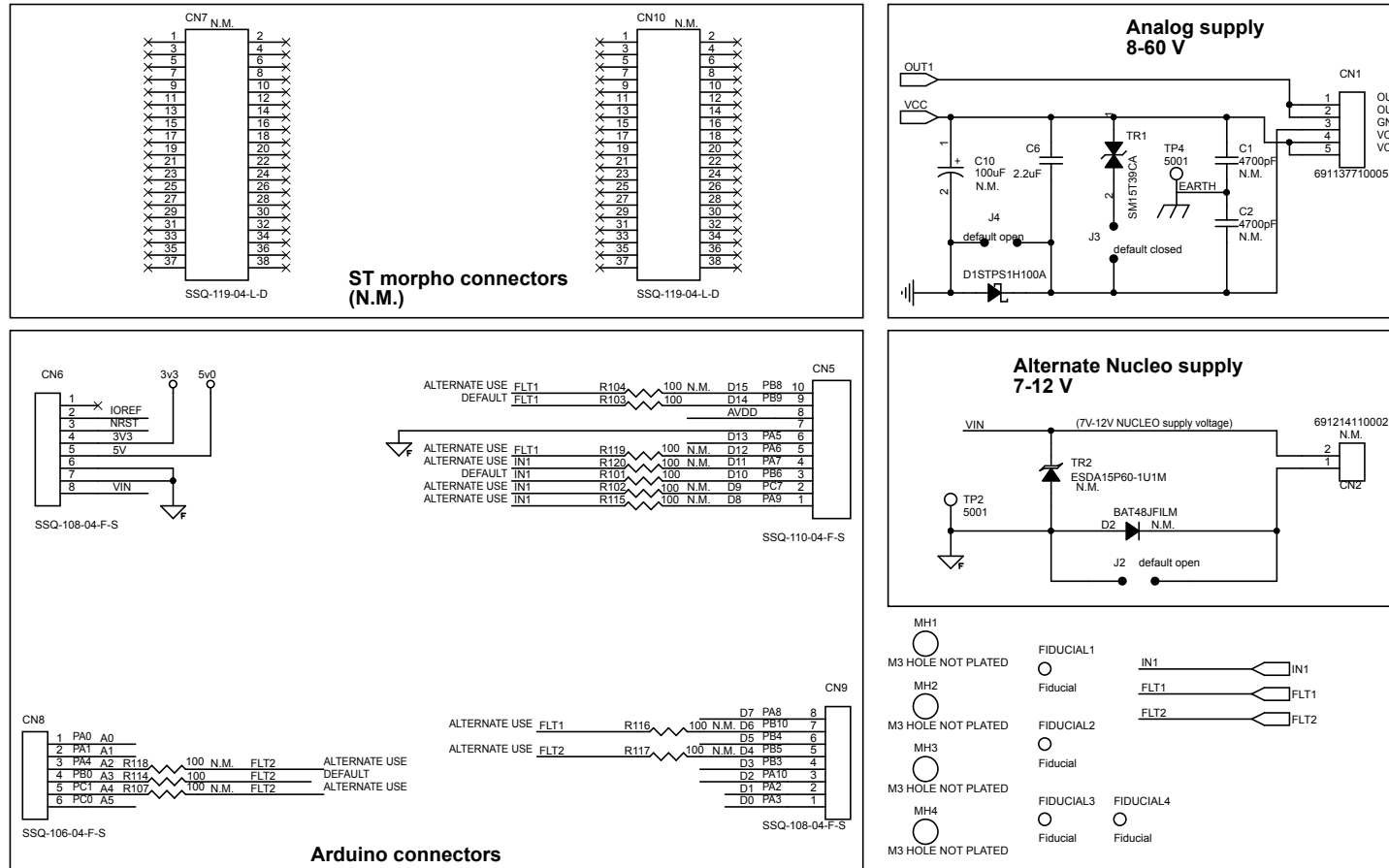
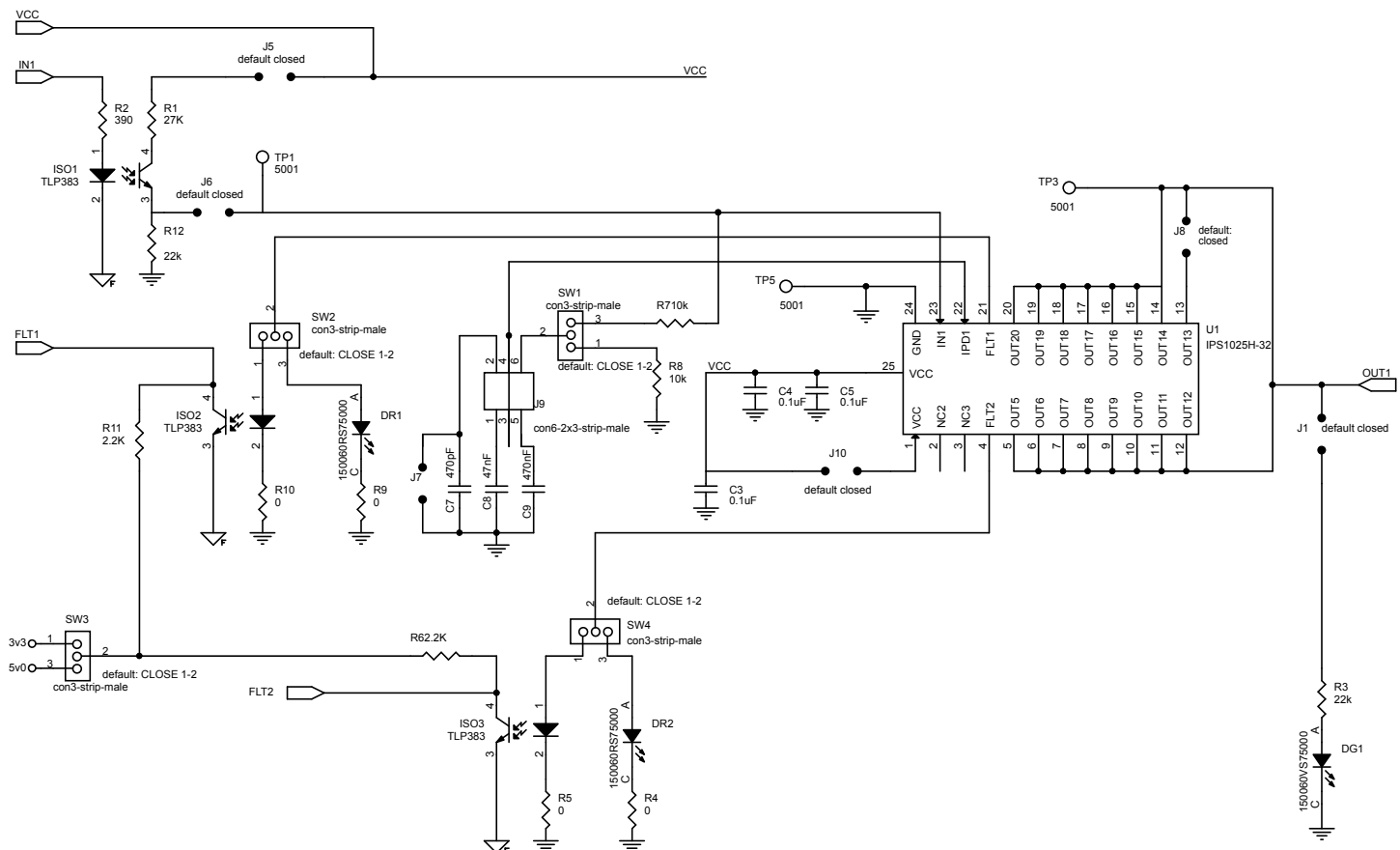

Figure 2. X-NUCLEO-OUT06A1 circuit schematic (2 of 2)



## 2 Board versions

**Table 1. X-NUCLEO-OUT06A1 versions**

Finished good	Schematic diagrams	Bill of materials
X\$NUCLEO-OUT06A1 <sup>(1)</sup>	X\$NUCLEO-OUT06A1 schematic diagrams	X\$NUCLEO-OUT06A1 bill of materials

1. This code identifies the X-NUCLEO-OUT06A1 evaluation board first version.

## Revision history

**Table 2. Document revision history**

Date	Version	Changes
24-Mar-2022	1	Initial release.