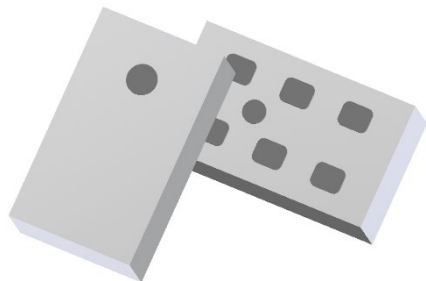


# Xinger® IV

## Ultra Small Low Profile 0603 Balun 50Ω to 100Ω Balanced



### Description

The X4BD40L1-50100G is an ultra-small low profile balanced to unbalanced transformer designed for differential inputs and output for 5G applications. The X4BD40L1-50100G is ideal for high volume manufacturing. The X4BD40L1-50100G is available on tape and reel for pick and place high volume manufacturing.

All of the Xinger components are constructed from ceramic filled PTFE composites, which possess excellent electrical and mechanical stability. All parts have been subjected to rigorous qualification testing and units are 100% RF tested. Produced in an ENIG final finish.

### Features:

- 2300-6000 MHz
- 50 Ohm to 2 x50 Ohm
- 5G Applications
- Very Low Loss
- Tight Amplitude Balance
- Input to Output DC Isolation
- Production Friendly
- Tape and Reel
- Non-conductive Surface
- RoHS Compliant
- Halogen Free

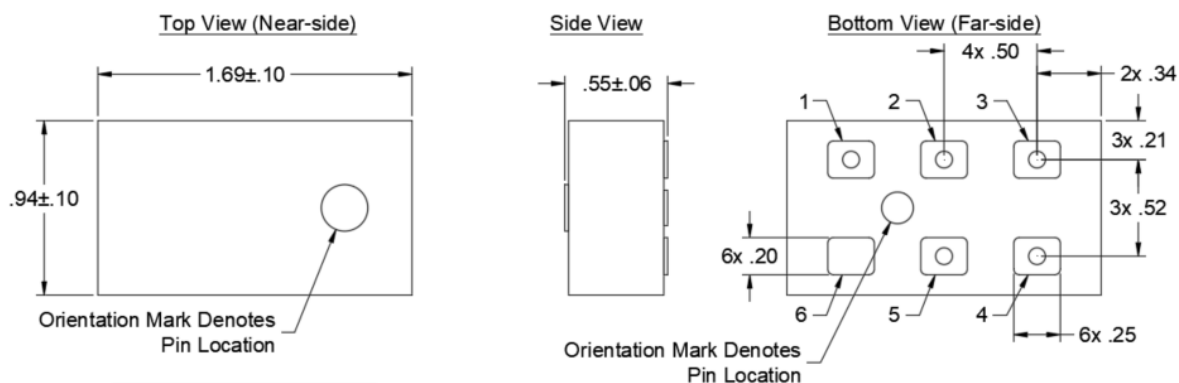
### Electrical Specifications \*\*

Frequency	Port Impedance	Insertion Loss	Return Loss	Amplitude Balance
<i>MHz</i>	<i>Unbalanced : Balanced</i>	<i>dB Max</i>	<i>dB Min</i>	<i>dB Max</i>
2300-2500	50:100	1.0	10.5	± 1.7
2500-6000	50:100	1.2	12.0	± 1.5
	<b>Phase Balance</b>	<b>CMRR</b>	<b>Power</b>	<b>Operating Temp.</b>
	<i>Degrees</i>	<i>dB Max</i>	<i>Avg. CW Watts @105°C</i>	<i>°C</i>
	± 4	20	1	-55 to +140
	± 7	20	1	-55 to +140

\*\*Specification based on performance of unit properly installed on Anaren Test Board with small signal applied.

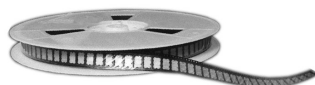
\*Specifications subject to change without notice. Refer to parameter definitions for details.

### Mechanical Outline

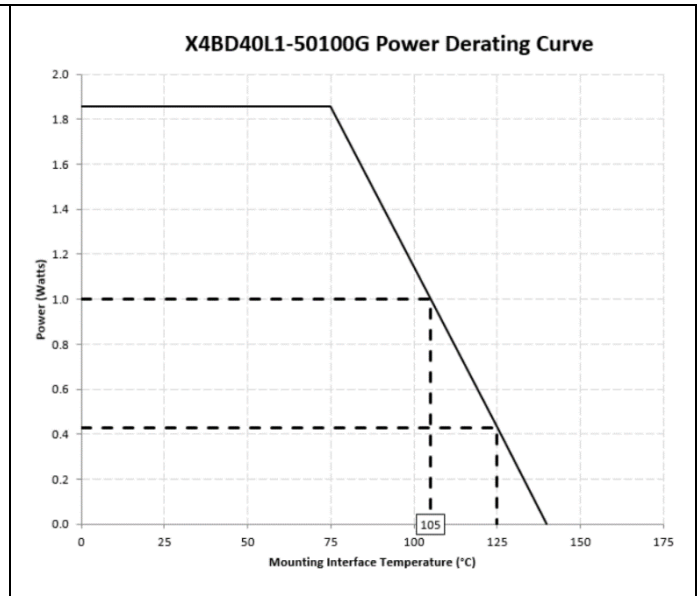
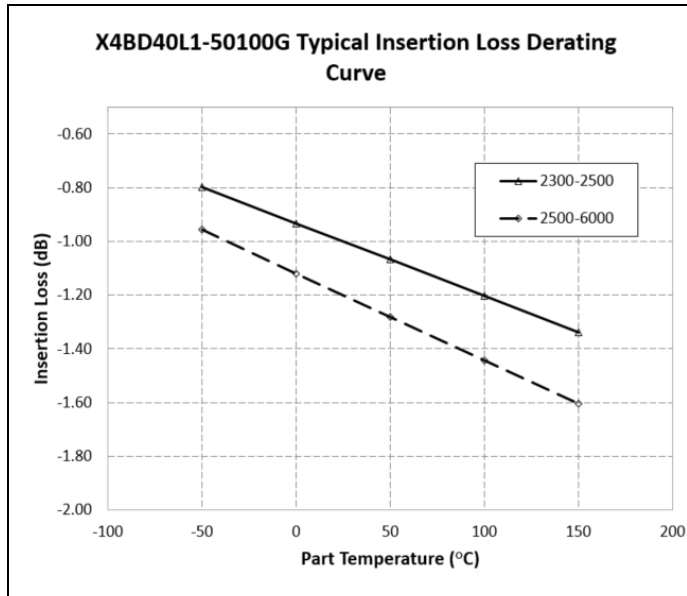


Pin	Designation
1	Unbalanced Port
2	DC Bias/GND
3	Balanced Port
4	Balanced Port
5	GND
6	NC

-Dimensions are in Millimeters  
 -Tolerances are Non-Cumulative



## Insertion Loss and Power Derating Curves



### Insertion Loss Derating:

The insertion loss, at a given frequency, of a group of couplers is measured at 25°C and then averaged. The measurements are performed under small signal conditions (i.e. using a Vector Network Analyzer). The process is repeated at 105°C and 140°C. A best-fit line for the measured data is computed and then plotted from -55°C to 140°C.

### Power Derating:

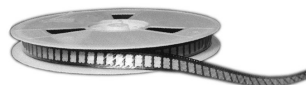
The power handling and corresponding power derating plots are a function of the thermal resistance, mounting surface temperature (base plate temperature), maximum continuous operating temperature of the coupler, and the thermal insertion loss. The thermal insertion loss is defined in the Power Handling section of the data sheet.

As the mounting interface temperature approaches the maximum continuous operating temperature, the power handling decreases to zero.

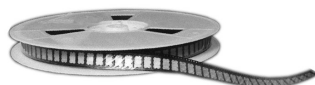
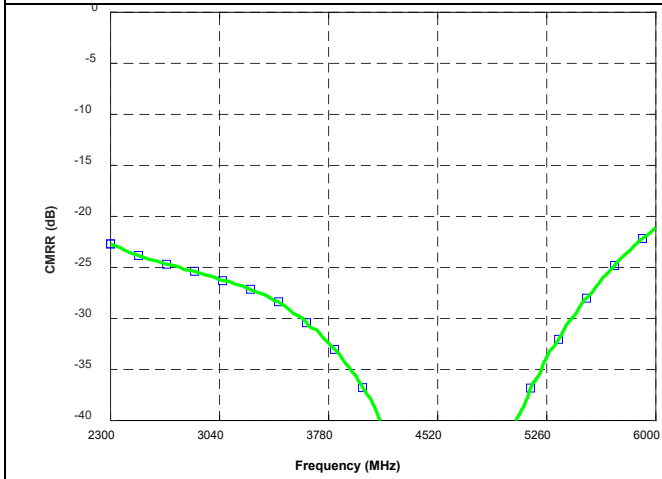
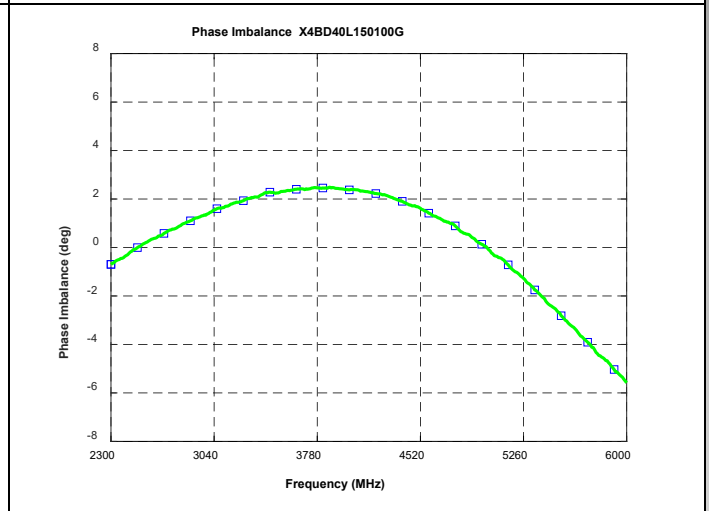
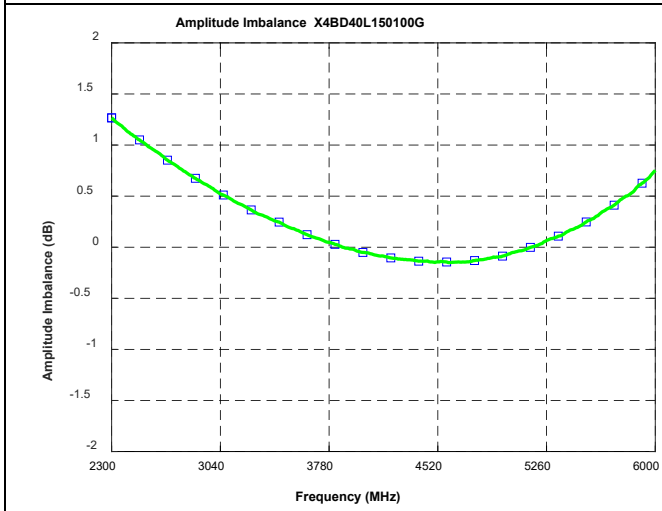
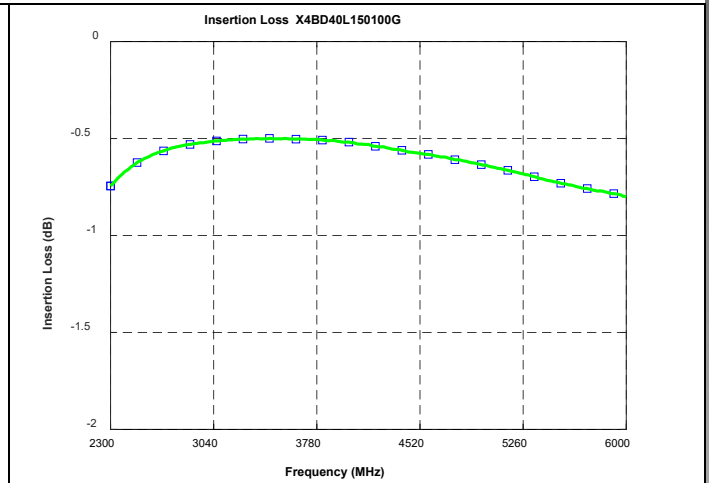
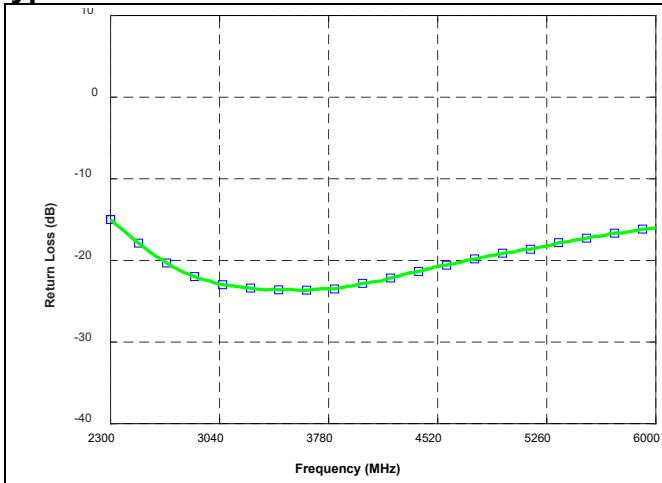
If mounting temperature is greater than 105°C, Xinger coupler will perform reliably as long as the input power is derated to the curve above.

USA/Canada: (315) 233-5510  
 Toll Free: (833) 389-6402  
 Europe: +44 2392-232392  
 Asia: +86 512 62749282

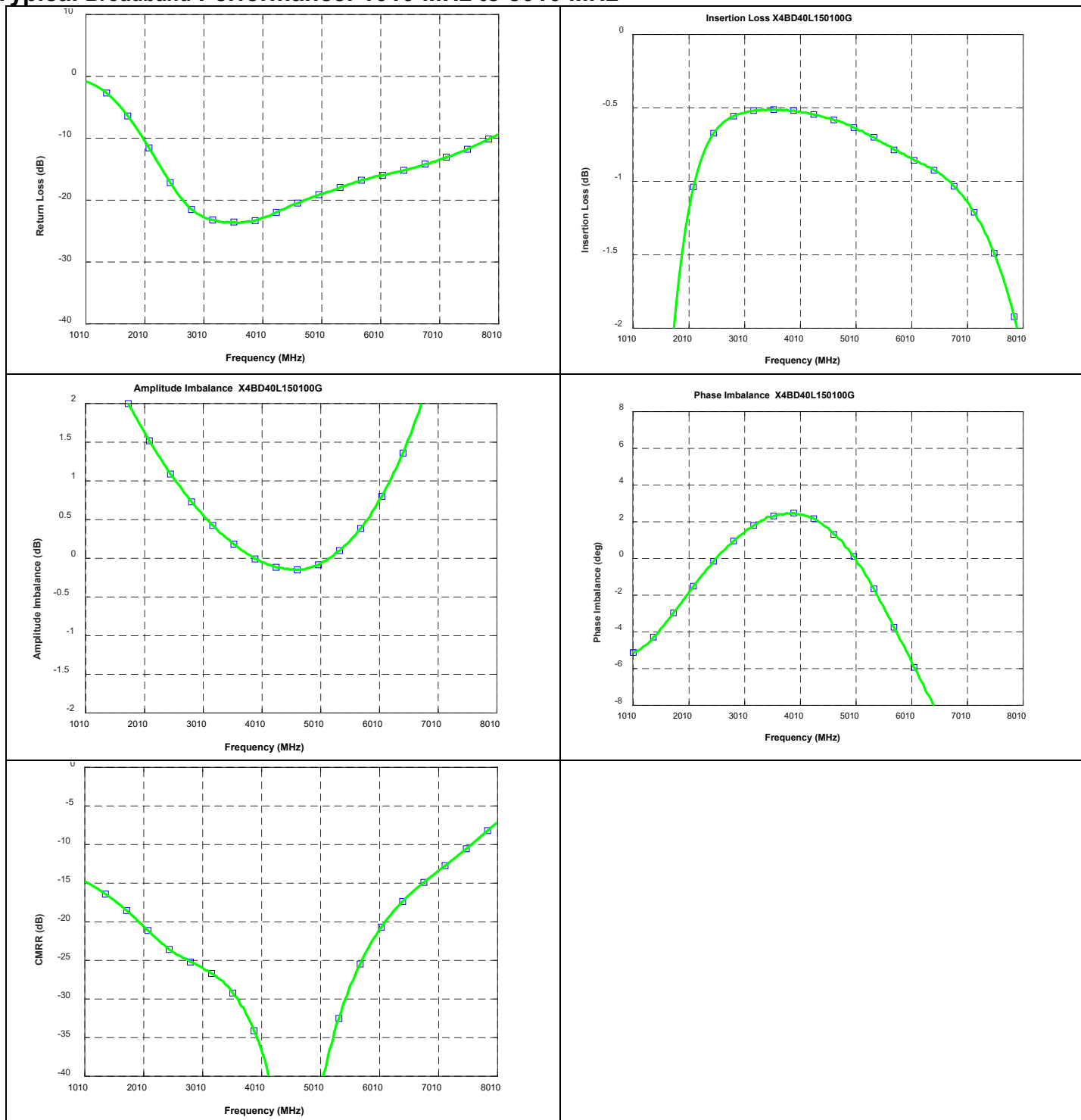
Available on Tape and Reel for Pick and Place Manufacturing.



### Typical Performance: 2300 MHz to 6000 MHz

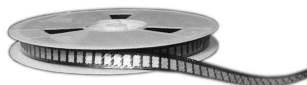


## Typical Broadband Performance: 1010 MHz to 8010 MHz



USA/Canada: (315) 233-5510  
 Toll Free: (833) 389-6402  
 Europe: +44 2392-232392  
 Asia: +86 512 62749282

Available on Tape and Reel for Pick and Place Manufacturing.



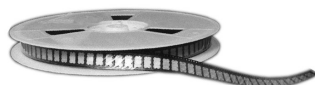
**Anaren®**  
 What'll we think of next?®

### Definition of Measured Specifications

Parameter	Definition	Mathematical Representation
<b>Return Loss</b>	The impedance match at the single ended port.	$RL = 20\text{Log}_{10}(S_{11})$
<b>Differential Port Return Loss</b>	The impedance match at the differential port.	$RLD = 20\text{Log}_{10} 0.5 * (S_{22} - S_{23} - S_{32} + S_{33}) $
<b>Insertion Loss</b>	Power loss from common mode to differential mode.	$ILD = 20\text{Log}_{10}(0.707 * (S_{21} - S_{31}))$
<b>Phase Imbalance</b>	The difference in phase angle between the two differential ports, offset by 180 deg.	$PB = (\text{Phase}(S_{21}) - \text{Phase}(S_{31})) - 180^\circ$
<b>Amplitude Imbalance</b>	The ratio of the power at differential ports.	$AB = 20\text{Log}_{10} \left  \frac{S_{21}}{S_{31}} \right $
<b>Common Mode Rejection Ratio</b>	The ratio of powers of the differential gain to the common-mode gain.	$CMRR = \pm 20\text{Log}_{10} \left( \frac{S_{21} + S_{31}}{S_{21} - S_{31}} \right)$

\*Parts are 100% RF tested as per spec definition.

\*\* Refer to page 6 for port assignment.



## Notes on RF Testing and Circuit Layout:

The effects of the test fixture on the measured data must be minimized in order to accurately determine the performance of the device under test. If the line impedance is anything other than 50Ω and/or there is a discontinuity at the microstrip to SMA interface, there will be errors in the data for the device under test. The test environment can never be “perfect”, but the procedure used to build and evaluate the test boards (outlined below) demonstrates an attempt to minimize the errors associated with testing these devices. The lower the signal level that is being measured, the more impact the fixture errors will have on the data. Parameters such as Return Loss and Isolation/Directivity, which are specified as low as 27dB and typically measure at much lower levels, will present the greatest measurement challenge.

**Note:** The S-parameter files that are available on the <https://www.anaren.com/> website include data for frequencies that are outside of the specified band.

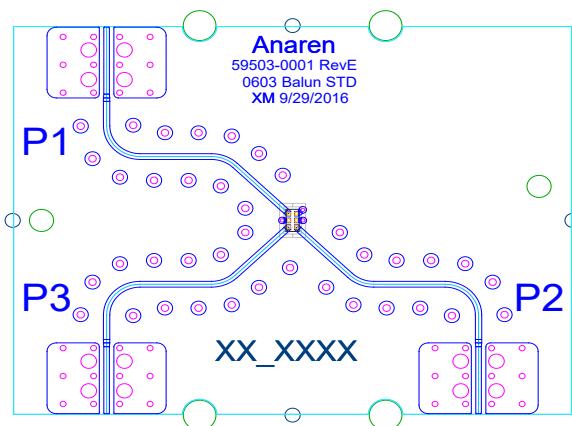
## Circuit Board Layout

The dimensions for the Anaren test board are shown below. The test board is printed on Rogers RO4003 material that is 0.008” thick. Consider the case when a different material is used. First, the pad size must remain the same to accommodate the part. But, if the material thickness or dielectric constant (or both) changes, the reactance at the interface to the component will also change. Second, the linewidth required for 50Ω will be different and this will introduce a step in the line at the pad where the component interfaces with the printed microstrip trace. Both of these conditions will affect the performance of the part. **To achieve the specified performance, serious attention must be given to the design and layout of the circuit environment in which this component will be used.**

If a different circuit board material is used, an attempt should be made to achieve the same interface pad reactance that is present on the Anaren RO4003 test board. When thinner circuit board material is used, the ground plane will be closer to the pad yielding more capacitance for the same size interface pad. The same is true if the dielectric constant of the circuit board material is higher than is used on the Anaren test board. In both of these cases, narrowing the line before the interface pad will introduce a series inductance, which, when properly tuned, will compensate for the extra capacitive reactance. If a thicker circuit board or one with a lower dielectric constant is used,

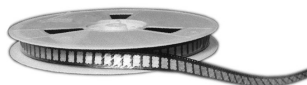
the interface pad will have less capacitive reactance than the Anaren test board. In this case, a wider section of line before the interface pad (or a larger interface pad) will introduce a shunt capacitance and when properly tuned will match the performance of the Anaren test board.

Notice that the board layout shown below is the same for all 0603 “L” size baluns.



USA/Canada: (315) 233-5510  
 Toll Free: (833) 389-6402  
 Europe: +44 2392-232392  
 Asia: +86 512 62749282

Available on Tape and  
 Reel for Pick and Place  
 Manufacturing.



**Anaren®**  
 What'll we think of next?®

### Testing Sample Parts Supplied on Anaren Test Boards

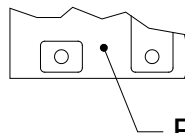
If you have received a component installed on an Anaren produced microstrip test board, please remember to remove the loss of the test board from the measured data. The loss is small enough that it is not of concern for Return Loss and Isolation/Directivity, but it should certainly be considered when measuring coupling and calculating the insertion loss of the component. An S-parameter file for a "Thru" board (see description of "Thru" board above) will be supplied upon request. As a first order approximation, one should consider the following loss estimates:

Frequency Band	Avg. Ins. Loss of Test Board @ 25°C
2200-2400 MHz	~0.447 dB
2500-2700 MHz	~0.463 dB
2800-3000 MHz	~0.506 dB
3000-3500 MHz	~0.543 dB
3500-4000 MHz	~0.613 dB
4000-6000 MHz	~0.737 dB

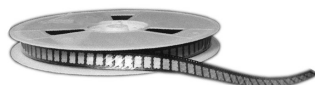
It is important to note that the loss of the test board will change with temperature and must be considered if the component is to be evaluated at other temperatures.

### Peak Power Handling

High-Pot testing of these components during the qualification procedure resulted in a minimum breakdown voltage of 1Kv (minimum recorded value). This voltage level corresponds to a breakdown resistance capable of handling at least 12dB peaks over average power levels, for very short durations. The breakdown location consistently occurred across the pads and the ground bar (see illustration below). The breakdown levels at these points will be affected by any contamination in the gap area around these pads. These areas must be kept clean for optimum performance. It is recommended that the user test for voltage breakdown under the maximum operating conditions and over worst case modulation induced power peaking. This evaluation should also include extreme environmental conditions (such as high humidity).



Breakdown Area



## Mounting

In order for Xinger surface mount components to work optimally, there must be 50Ω transmission lines leading to and from all of the RF ports. Also, there must be a very good ground plane underneath the part to ensure proper electrical performance. If either of these two conditions is not satisfied, electrical performance may not meet published specifications.

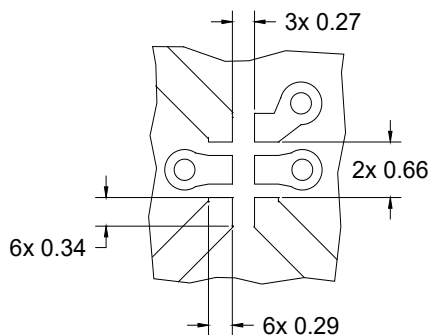
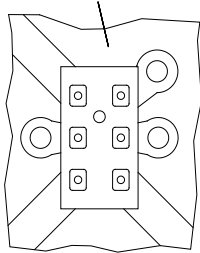
Overall ground is improved if a dense population of plated through holes connect the top and bottom ground layers of the PCB. This minimizes ground inductance and improves ground continuity. All of the Xinger hybrid and Hybrid components are constructed from ceramic filled PTFE composites, which possess excellent electrical and mechanical stability.

When a surface mount component is mounted to a printed circuit board, the primary concerns are; ensuring the RF pads of the device are in contact with the circuit trace of the PCB and insuring the ground plane of neither the component nor the PCB is in contact with the RF signal.

## Mounting Footprint

Dimensions are in Millimeters

To ensure proper electrical and thermal performance there must be a ground plane with 100% solder connection as shown



## Component Mounting Process

The process for assembling this component is a conventional surface mount process as shown in Figure 2. This process is conducive to both low and high volume usage.



Figure 2: Surface Mounting Process Steps

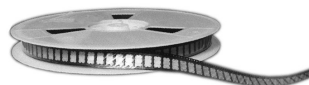
**Storage of Components:** The Xinger products are available in an ENIG finish. IPC storage conditions used to control oxidation should be followed for these surface mount components.

**Substrate:** Depending upon the particular component, the circuit material has a coefficient of thermal expansion (CTE) similar to commonly used board substrates such as RF35, RO4003, FR4, polyimide and G-10 materials. The similarity in CTE minimizes solder joint stresses due to similar expansion rates between component and board. Mounting to “hard” substrates (alumina etc.) is possible depending upon operational temperature requirements. The solder surfaces of the component are all copper plated with an ENIG.

**Solder Paste:** All conventional solder paste formulations will work well with Anaren’s Xinger surface mount components. Solder paste can be applied with stencils or syringe dispensers. An example of a stenciled solder paste deposit is shown in Figure 3. As shown in the figure solder paste is applied to the four RF pads and the entire ground plane underneath the body of the part.

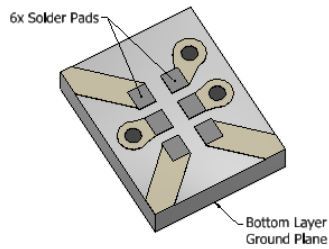
USA/Canada: (315) 233-5510  
 Toll Free: (833) 389-6402  
 Europe: +44 2392-232392  
 Asia: +86 512 62749282

Available on Tape and Reel for Pick and Place Manufacturing.



**Anaren®**  
 What'll we think of next?®

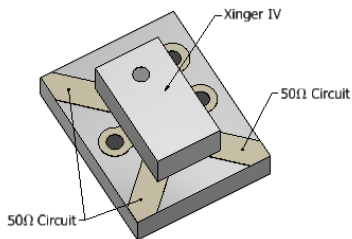




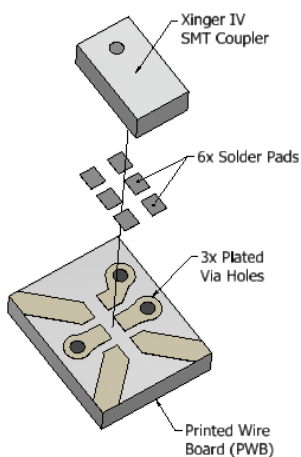
**Figure 3: Solder Paste Application**

**Component Positioning:** The surface mount component can be placed manually or with automatic pick and place mechanisms. Couplers should be placed (see Figure 4 and 5) onto wet paste with common surface mount techniques and parameters. Pick and place systems must supply adequate vacuum to hold a 0.01 gram coupler.

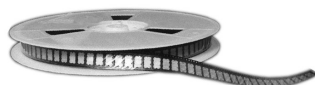
**Reflow:** The surface mount coupler is conducive to most of today's conventional reflow methods. A low and high temperature thermal reflow profile are shown in Figures 6 and 7, respectively. Manual soldering of these components can be done with conventional surface mount non-contact hot air soldering tools. Board pre-heating is highly recommended for these selective hot air soldering methods. Manual soldering with conventional irons should be avoided.



**Figure 4: Component Placement**



**Figure 5: Mounting Features Example**






## Mounting Configuration:

In order for Xinger surface mount components to work optimally, the proper impedance transmission lines must be used to connect to the RF ports. If this condition is not satisfied, insertion loss, Isolation and VSWR may not meet published specifications.

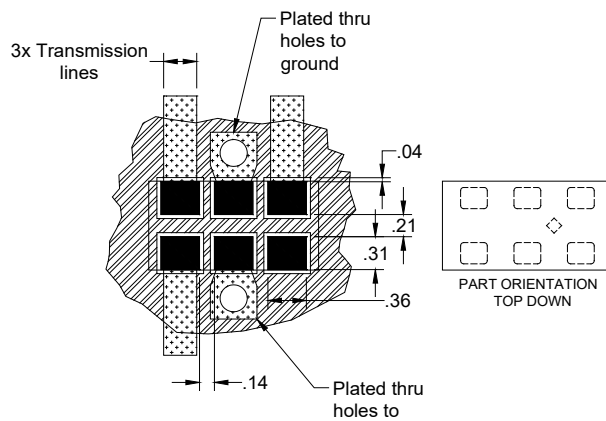
All of the Xinger components are constructed from organic PTFE based composites which possess excellent electrical and mechanical stability. Xinger components are compliant to a variety of ROHS and Green standards and ready for Pb-free soldering processes. Pads are Gold plated with a Nickel barrier.

An example of the PCB footprint used in the testing of these parts is shown below. An example of a DC-biased footprint is also shown below. In specific designs, the transmission line widths need to be adjusted to the unique dielectric coefficients and thicknesses as well as varying pick and place equipment tolerances.




### No Bias Footprint

-  Circuit Pattern
-  Footprint Pad (s)
-  Solder Resist

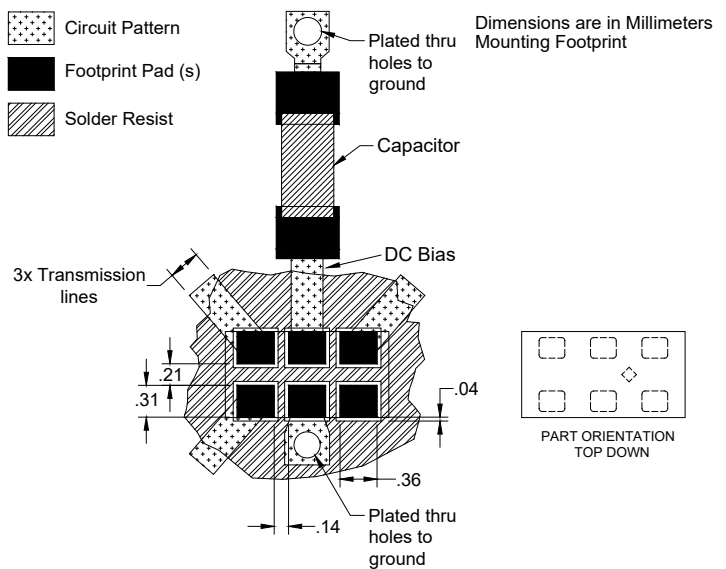
Dimensions are in Millimeters  
Mounting Footprint



### DC Bias Footprint

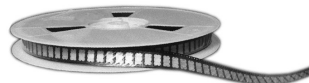
-  Circuit Pattern
-  Footprint Pad (s)
-  Solder Resist

Dimensions are in Millimeters  
Mounting Footprint



USA/Canada: (315) 233-5510  
Toll Free: (833) 389-6402  
Europe: +44 2392-232392  
Asia: +86 512 62749282

Available on Tape and Reel for Pick and Place Manufacturing.



**Anaren®**  
What'll we think of next?®

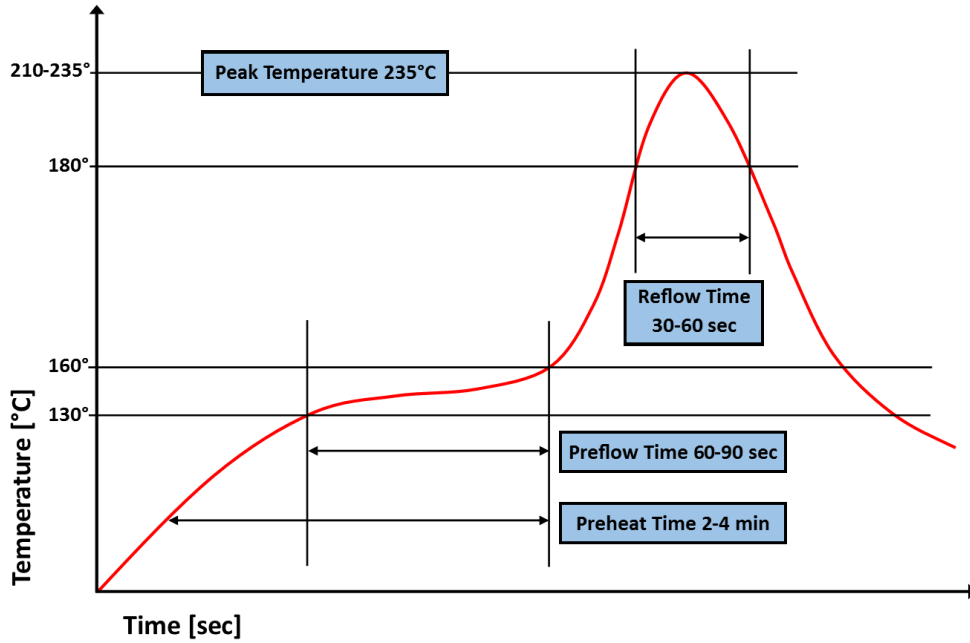


Figure 6 – Low Temperature Solder Reflow Thermal Profile

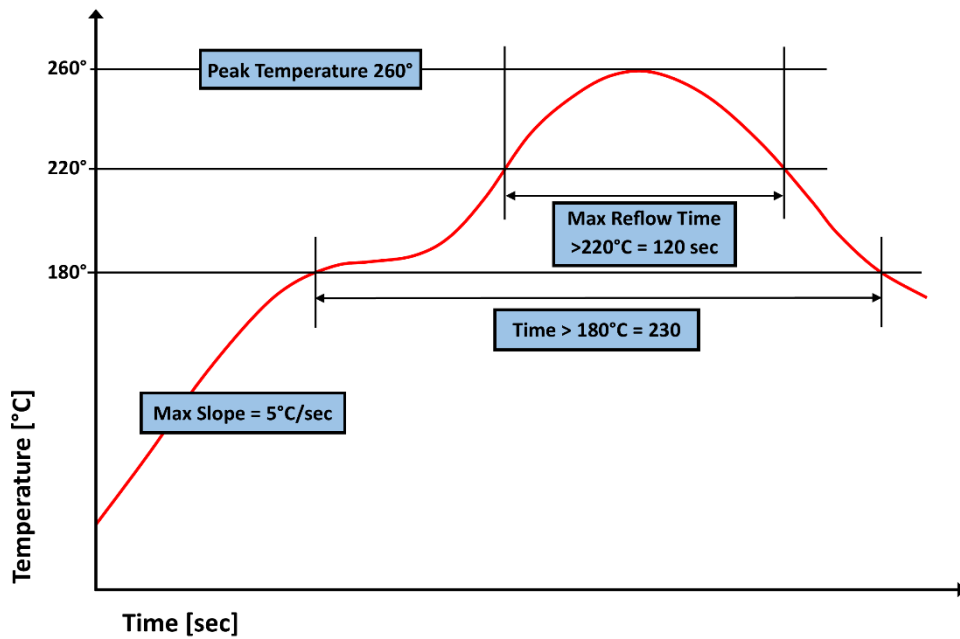


Figure 7 – High Temperature Solder Reflow Thermal Profile

