

## Inductor Built-in Step-up “micro DC/DC” Converter

☆GreenOperation Compatible

## ■ GENERAL DESCRIPTION

The XCL101 series is a synchronous step-up micro DC/DC converter which integrates an inductor and a control IC in one tiny package (2.5mm × 2.0mm, H=1.0mm). A stable step-up power supply is configured using only two capacitors connected externally. An internal coil simplifies the circuit and enables minimization of noise and other operational trouble due to the circuit wiring. The XCL101 series can be used in applications that start from a single alkaline or nickel-metal hydride battery because the input voltage range is 0.9V ~ 5.5V. The output voltage can be set from 1.8V to 5.0V ( $\pm 2.0\%$ ) in steps of 0.1V. PFM control enables a low quiescent current, making these products ideal for portable devices that require high efficiency. The XCL101 features a load disconnect function to break continuity between the input and output at shutdown (XCL101A), and a bypass mode function to maintain continuity between the input and output (XCL101C).

## ■ APPLICATIONS

- Wearable devices
- Mobile phones, Smart phones
- Mouses, Keyboards
- Remote controls
- Portable information devices
- Game consoles

## ■ FEATURES

Input Voltage Range	: 0.9V~5.5V
Output Voltage Range	: 1.8V~5.0V ( $\pm 2.0\%$ ) 0.1V increment
Output Current	: 100mA@ $V_{OUT}=3.3V$ , $V_{BAT}=1.8V$ (TYP.)
Supply Current	: 6.3 $\mu$ A ( $V_{BAT}=V_{OUT}+0.5V$ )
Control Method	: PFM Control
PFM Switching Current	: 350mA
Functions	: Load Disconnection Function or Bypass Mode Function
	: Ceramic Capacitor Compatible
Operating Ambient Temperature	: -40°C ~ +85°C
Package	: CL-2025, CL-2025-02
Environmentally Friendly	: EU RoHS Compliant, Pb Free

## ■ TYPICAL APPLICATION CIRCUIT

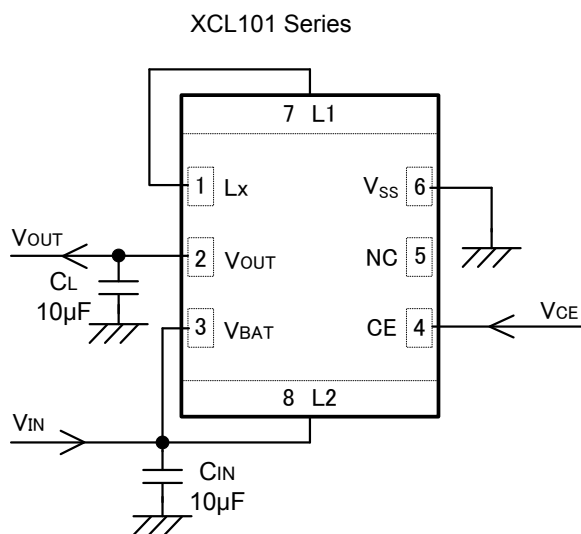

(TOP VIEW)

“L1 and Lx”, “L2 and VBAT” is connected by PCB pattern.

## ■ TYPICAL PERFORMANCE CHARACTERISTICS

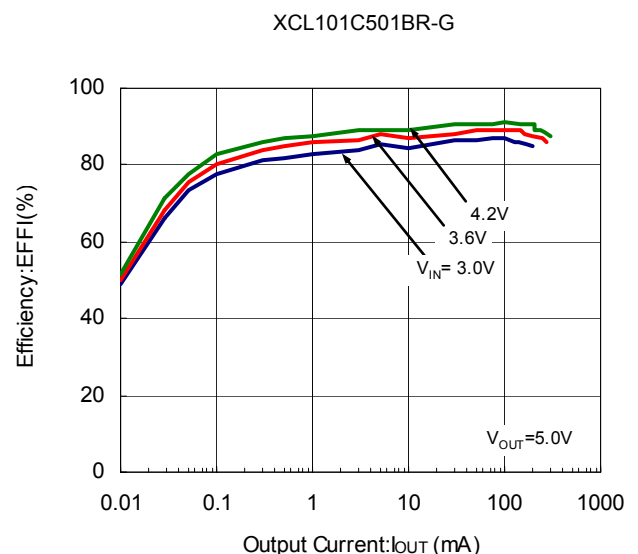

## ■ BLOCK DIAGRAM

XCL101A / XCL101C

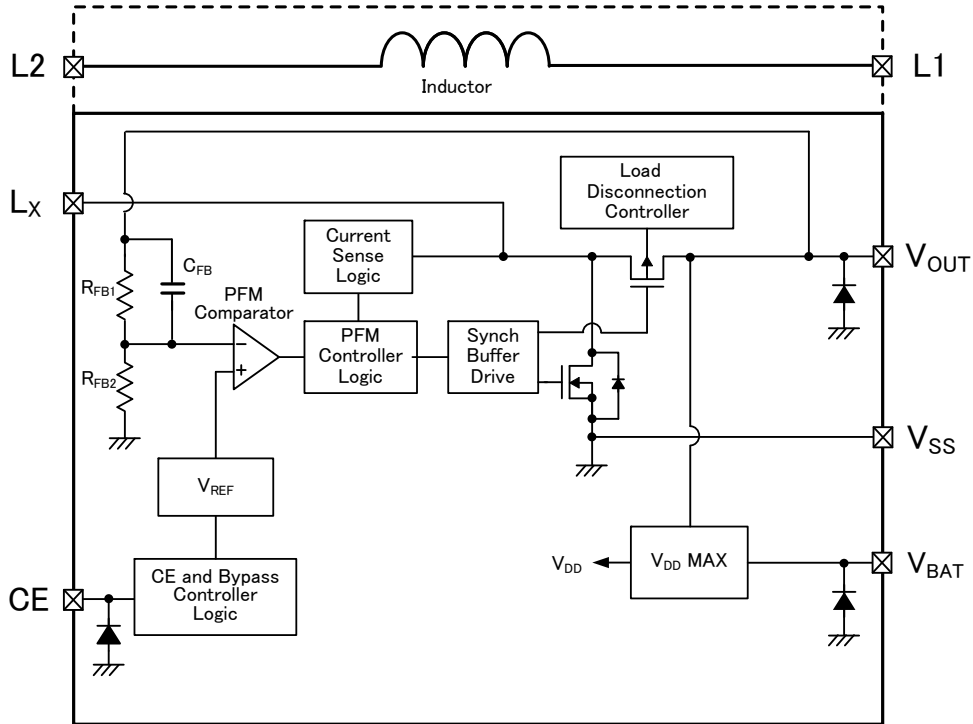

\* Diodes inside the circuits are ESD protection diodes and parasitic diodes.

## ■ PRODUCTION CLASSIFICATION

### ● Ordering Information

XCL101①②③④⑤⑥-⑦(\*1) PFM control

DESIGNATOR	ITEM	SYMBOL	DESCRIPTION
①	Product Type	A	Load Disconnection
		C	V <sub>BAT</sub> Bypass
②③	Output Voltage	18~50	Output Voltage e.g. V <sub>OUT</sub> =1.8V ⇒ ②=1、③=8
④	Oscillation Frequency	1	1.2MHz
⑤⑥-⑦	Package (Order Unit)	BR-G(*2)	CL-2025 (3,000/Reel)
		ER-G(*3)	CL-2025-02 (3,000/Reel)

(\*1)The "-G" suffix denotes Halogen and Antimony free as well as being fully EU RoHS compliant.

(\*2) BR-G is storage temperature range "-40 °C ~ + 105 °C".

(\*3) ER-G is storage temperature range "-40 °C ~ + 125 °C".

## ■ PIN CONFIGURATION

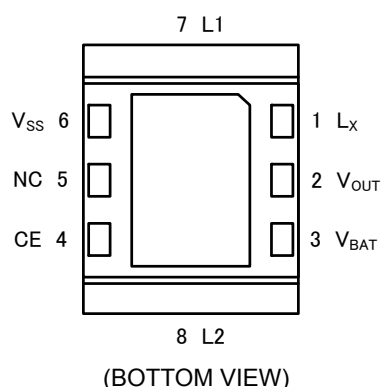

- \* If the dissipation pad needs to be connected to other pins, it should be connected to the  $V_{SS}$  pin.
- \* Please refer to pattern layout page for the connecting to PCB.

## ■ PIN ASSIGNMENT

PIN NUMBER	PIN NAME	FUNCTIONS
1	L <sub>X</sub>	Switching
2	V <sub>OUT</sub>	Output Voltage
3	V <sub>BAT</sub>	Power Input
4	CE	Chip Enable
5	NC	No Connection
6	V <sub>SS</sub>	Ground
7	L1	Inductor Electrodes
8	L2	

## ■ CE PIN FUNCTION

PIN NAME	SIGNAL	STATUS
CE	H	Operation (All Series)
	L	XCL101A Series: Stand-by XCL101C Series: Bypass Mode

\* Please do not leave the CE pin open.

## ■ ABSOLUTE MAXIMUM RATINGS

T<sub>a</sub>=25°C

PARAMETER	SYMBOL	RATINGS	UNITS
V <sub>BAT</sub> Pin Voltage	V <sub>BAT</sub>	-0.3 ~ +7.0	V
L <sub>X</sub> Pin Voltage	V <sub>LX</sub>	-0.3 ~ V <sub>OUT</sub> +0.3 or +7.0 <sup>(*)1</sup>	V
V <sub>OUT</sub> Pin Voltage	V <sub>OUT</sub>	-0.3 ~ +7.0	V
CE Pin Voltage	V <sub>CE</sub>	-0.3 ~ +7.0	V
L <sub>X</sub> Pin Current	I <sub>LX</sub>	700	mA
Power Dissipation	P <sub>d</sub>	1000 <sup>(*)2</sup>	mW
Operating Ambient Temperature	T <sub>opr</sub>	- 40 ~ +85	°C
Storage Temperature <sup>(*)3</sup>	CL-2025	T <sub>stg</sub>	- 40 ~ +105
	CL-2025-02		- 40 ~ +125

All voltages are described based on the GND.

(\*)1 The maximum value should be either V<sub>OUT</sub>+0.3V or +7.0V in the lowest.

(\*)2 The power dissipation figure shown is PCB mounted (40mm x 40mm, t=1.6mm, Glass Epoxy FR-4).

(\*)3 Storage temperature, are divided by the product specification of the package.

## ELECTRICAL CHARACTERISTICS

XCL101Axx1BR-G/XCL101Axx1ER-G

Ta=25 °C

PARAMETER	SYMBOL	CONDITIONS	MIN.	TYP.	MAX.	UNITS	CIRCUIT
Input Voltage	V <sub>BAT</sub>	-	-	-	5.5	V	-
Output Voltage	V <sub>OUT(E)</sub> <sup>(2)</sup>	V <sub>PULL</sub> =1.5V, Voltage to start oscillation while V <sub>OUT</sub> is decreasing	<E1>			V	①
Operation Start Voltage	V <sub>ST1</sub>	I <sub>OUT</sub> =1mA	-	-	0.9	V	②
Operation Hold Voltage	V <sub>HLD</sub>	R <sub>L</sub> =1kΩ	-	0.7	-	V	②
Supply Current	I <sub>q</sub>	Oscillation stops, V <sub>BAT</sub> =V <sub>CE</sub> =1.5V V <sub>OUT</sub> =V <sub>OUT(T)</sub> <sup>(1)</sup> +0.5V	<E2>			μA	③
Input Pin Current	I <sub>BAT</sub>	V <sub>OUT</sub> =V <sub>OUT(T)</sub> <sup>(1)</sup> +0.5V	-	0.25	1.0	μA	③
Stand-by Current	I <sub>STB</sub>	V <sub>BAT</sub> =V <sub>LX</sub> =V <sub>OUT(T)</sub> <sup>(1)</sup> , V <sub>OUT</sub> =V <sub>CE</sub> =0V	-	0.1	1.0	μA	④
L <sub>X</sub> Leak Current	I <sub>LXL</sub>	V <sub>BAT</sub> =V <sub>LX</sub> =V <sub>OUT(T)</sub> <sup>(1)</sup> , V <sub>OUT</sub> =V <sub>CE</sub> =0V	-	0.1	1.0	μA	⑤
PFM Switching Current	I <sub>PFM</sub>	I <sub>OUT</sub> =3mA	295	350	405	mA	②
Maximum On Time	t <sub>ONMAX</sub>	V <sub>PULL</sub> =1.5V, V <sub>OUT</sub> =V <sub>OUT(T)</sub> <sup>(1)</sup> ×0.98V	3.1	4.6	6.0	μs	①
L <sub>X</sub> SW "Pch" ON Resistance <sup>(3)</sup>	R <sub>LXP</sub>	V <sub>BAT</sub> =V <sub>CE</sub> =V <sub>LX</sub> =V <sub>OUT(E)</sub> <sup>(2)</sup> +0.5V, I <sub>OUT</sub> =200mA	<E3>			Ω	⑦
L <sub>X</sub> SW "Nch" ON Resistance <sup>(4)</sup>	R <sub>LXN</sub>	V <sub>BAT</sub> =V <sub>OUT(E)</sub> <sup>(2)</sup> =3.3V, V <sub>OUT</sub> =1.7V	-	0.6	-	Ω	⑧
CE "High" Voltage	V <sub>CEH</sub>	V <sub>BAT</sub> =V <sub>PULL</sub> =1.5V V <sub>OUT</sub> =V <sub>OUT(T)</sub> <sup>(1)</sup> ×0.98V While V <sub>CE</sub> =0.3→0.75V, Voltage to start oscillation	0.75	-	5.5	V	①
CE "Low" Voltage	V <sub>CEL</sub>	V <sub>BAT</sub> =V <sub>PULL</sub> =1.5V V <sub>OUT</sub> =V <sub>OUT(T)</sub> <sup>(1)</sup> ×0.98V While V <sub>CE</sub> =0.75→0.3V, Voltage to stop oscillation	V <sub>SS</sub>	-	0.3	V	①
CE "High" Current	I <sub>CEH</sub>	V <sub>BAT</sub> =V <sub>CE</sub> =V <sub>LX</sub> =V <sub>OUT</sub> =5.5V	-0.1	-	0.1	μA	①
CE "Low" Current	I <sub>CEL</sub>	V <sub>BAT</sub> =V <sub>LX</sub> =V <sub>OUT</sub> =5.5V, V <sub>CE</sub> =0V	-0.1	-	0.1	μA	①
Inductance Value	L	Test Frequency=1MHz	-	4.7	-	μH	-
(Inductor) Rated Current	I <sub>DC</sub>	ΔT=+40°C	-	700	-	mA	-

Unless otherwise stated, V<sub>BAT</sub>=V<sub>CE</sub>=1.5V

<sup>(1)</sup> V<sub>OUT(T)</sub> =Nominal Output Voltage

<sup>(2)</sup> V<sub>OUT(E)</sub> =Effective Output Voltage

The actual output voltage value V<sub>OUT(E)</sub> is the PFM comparator threshold voltage in the IC. Therefore, the DC/DC circuit output voltage, including the peripheral components, is boosted by the ripple voltage average value. Please refer to the characteristic example.

<sup>(3)</sup> L<sub>X</sub> SW "Pch" ON resistance = (V<sub>LX</sub>-V<sub>OUTpin</sub> measurement voltage) / 200mA

<sup>(4)</sup> L<sub>X</sub> SW "Nch" ONresistance measurement method is shown in the measurement circuit diagram.

## ■ ELECTRICAL CHARACTERISTICS (Continued)

XCL101Cxx1BR-G/XCL101Cxx1ER-G

Ta=25 °C

PARAMETER	SYMBOL	CONDITIONS	MIN.	TYP.	MAX.	UNITS	CIRCUIT
Input Voltage	V <sub>BAT</sub>	-	-	-	5.5	V	-
Output Voltage	V <sub>OUT(E)</sub> <sup>(*2)</sup>	V <sub>PULL</sub> =1.5V, Voltage to start oscillation while V <sub>OUT</sub> is decreasing	<E1>			V	①
Operation Start Voltage	V <sub>ST1</sub>	I <sub>OUT</sub> =1mA	-	-	0.9	V	②
Operation Hold Voltage	V <sub>HLD</sub>	R <sub>L</sub> =1kΩ	-	0.7	-	V	②
Supply Current	I <sub>q</sub>	Oscillation stops, V <sub>OUT</sub> =V <sub>OUT(T)</sub> +0.5V <sup>(*1)</sup>	<E2>			μA	③
Input Pin Current	I <sub>BAT</sub>	V <sub>BAT</sub> =V <sub>CE</sub> =1.5V, V <sub>OUT</sub> =V <sub>OUT(E)</sub> <sup>(*2)</sup> +0.5V	-	0.25	1.0	μA	③
Bypass Mode Current	I <sub>BYP</sub>	V <sub>BAT</sub> =V <sub>LX</sub> =5.5V, V <sub>CE</sub> =0V	-	3.5	6.1	μA	⑥
PFM Switching Current	I <sub>PFM</sub>	I <sub>OUT</sub> =3mA	295	350	405	mA	②
Maximum On Time	t <sub>ONMAX</sub>	V <sub>PULL</sub> =1.5V, V <sub>OUT</sub> =V <sub>OUT(T)</sub> <sup>(*1)</sup> ×0.98V	3.1	4.6	6.0	μs	①
Lx SW "Pch" ON Resistance <sup>(*3)</sup>	R <sub>LXP</sub>	V <sub>BAT</sub> =V <sub>LX</sub> =V <sub>CE</sub> =V <sub>OUT(E)</sub> <sup>(*2)</sup> +0.5V, I <sub>OUT</sub> =200mA	<E3>			Ω	⑦
Lx SW "Nch" ON Resistance <sup>(*4)</sup>	R <sub>LXN</sub>	V <sub>BAT</sub> =V <sub>OUT(E)</sub> <sup>(*2)</sup> =3.3V, V <sub>OUT</sub> =1.7V	-	0.6	-	Ω	⑧
CE "High" Voltage	V <sub>CEH</sub>	V <sub>BAT</sub> =V <sub>PULL</sub> =1.5V V <sub>OUT</sub> =V <sub>OUT(T)</sub> <sup>(*1)</sup> ×0.98V While V <sub>CE</sub> =0.3→0.75V, Voltage to start oscillation	0.75	-	5.5	V	①
CE "Low" Voltage	V <sub>CEL</sub>	V <sub>BAT</sub> =V <sub>PULL</sub> =1.5V V <sub>OUT</sub> =V <sub>OUT(T)</sub> <sup>(*1)</sup> ×0.98V While V <sub>CE</sub> =0.75→0.3V, Voltage to stop oscillation	V <sub>SS</sub>	-	0.3	V	①
CE "High" Current	I <sub>CEH</sub>	V <sub>BAT</sub> =V <sub>CE</sub> =V <sub>LX</sub> =V <sub>OUT</sub> =5.5V	-0.1	-	0.1	μA	①
CE "Low" Current	I <sub>CEL</sub>	V <sub>BAT</sub> =V <sub>LX</sub> =V <sub>OUT</sub> =5.5V, V <sub>CE</sub> =0V	-0.1	-	0.1	μA	①
Inductance Value	L	Test Frequency=1MHz	-	4.7	-	μH	-
(Inductor) Rated Current	I <sub>DC</sub>	ΔT=+40°C	-	700	-	mA	-

Unless otherwise stated, V<sub>BAT</sub>= V<sub>CE</sub>= 1.5V

<sup>(\*1)</sup> V<sub>OUT(T)</sub> =Nominal Output Voltage

<sup>(\*2)</sup> V<sub>OUT(E)</sub> =Effective Output Voltage

The actual output voltage value V<sub>OUT(E)</sub> is the PFM comparator threshold voltage in the IC. Therefore, the DC/DC circuit output voltage, including the peripheral components, is boosted by the ripple voltage average value. Please refer to the characteristic example.

<sup>(\*3)</sup> Lx SW "Pch" ON resistance = (V<sub>LX</sub>-V<sub>OUTpin</sub> measurement voltage) / 200mA

<sup>(\*4)</sup> Lx SW "Nch" ONresistance measurement method is shown in the measurement circuit diagram.

## ELECTRICAL CHARACTERISTICS (Continued)

SYMBOL	E1		E2		E3	
PARAMETER	OUTPUT VOLTAGE		SUPPLY CURRENT		L <sub>x</sub> SW "Pch" ON RESISTANCE	
UNITS:V	UNITS:V		UNITS:μA		UNITS:Ω	
OUTPUT VOLTAGE	MIN	MAX	TYP	MAX	TYP	MAX
1.8	1.764	1.836	6.1	9.4	0.84	1.08
1.9	1.862	1.938				
2.0	1.960	2.040				
2.1	2.058	2.142				
2.2	2.156	2.244				
2.3	2.254	2.346	6.2	9.7	0.75	0.97
2.4	2.352	2.448				
2.5	2.450	2.550				
2.6	2.548	2.652				
2.7	2.646	2.754				
2.8	2.744	2.856				
2.9	2.842	2.958	6.3	10.0	0.65	0.85
3.0	2.940	3.060				
3.1	3.038	3.162				
3.2	3.136	3.264				
3.3	3.234	3.366				
3.4	3.332	3.468	6.4	10.2	0.61	0.78
3.5	3.430	3.570				
3.6	3.528	3.672				
3.7	3.626	3.774				
3.8	3.724	3.876				
3.9	3.822	3.978	6.5	10.4	0.57	0.74
4.0	3.920	4.080				
4.1	4.018	4.182				
4.2	4.116	4.284				
4.3	4.214	4.386				
4.4	4.312	4.488				
4.5	4.410	4.590	6.7	10.7	0.53	0.72
4.6	4.508	4.692				
4.7	4.606	4.794				
4.8	4.704	4.896				
4.9	4.802	4.998				
5.0	4.900	5.100				

## TEST CIRCUITS

<Test Circuit No.①>

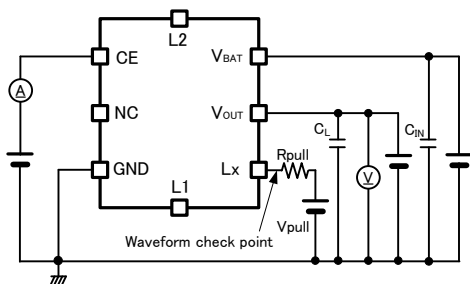

\*External components  
C<sub>IN</sub>:4.7 μF(Ceramic)  
C<sub>L</sub>:10 μF(Ceramic)  
R<sub>pull</sub>:100 ohm

<Test Circuit No.⑤>

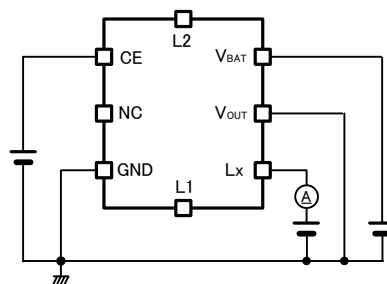

<Test Circuit No.②>

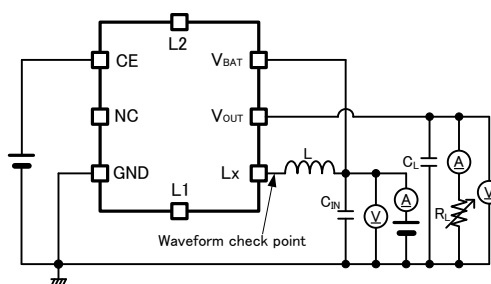

\*External components  
C<sub>IN</sub>:4.7 μF(Ceramic)  
C<sub>L</sub>:10 μF(Ceramic)  
L:4.7 μH(Selected goods)

<Test Circuit No.⑥>

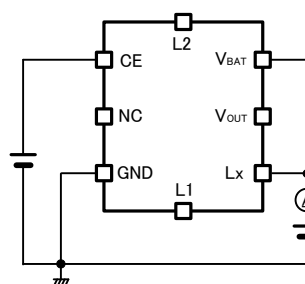

<Test Circuit No.③>

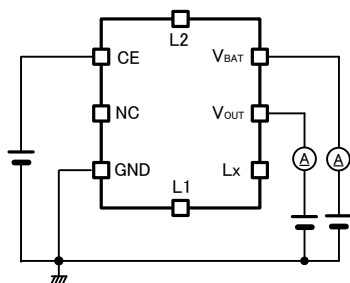

<Test Circuit No.⑦>

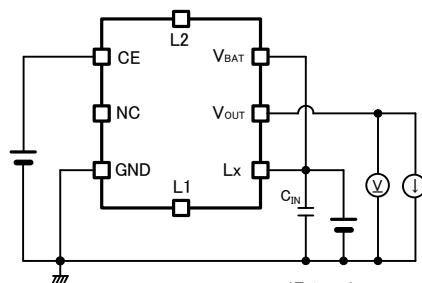

\*External components  
C<sub>IN</sub>:4.7 μF(Ceramic)

<Test Circuit No.④>

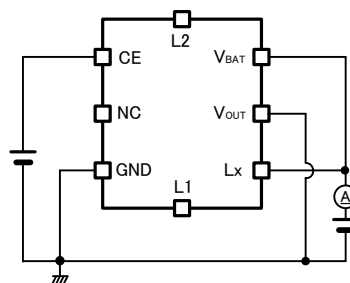

<Test Circuit No.⑧>

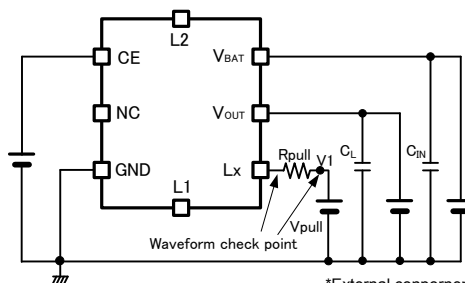

\*External components  
C<sub>IN</sub>:4.7 μF(Ceramic)  
C<sub>L</sub>:10 μF(Ceramic)  
R<sub>pull</sub>:4.7 ohm

### <L<sub>X</sub> SW "Nch" ON Resistance Measurement Method>

Use Test Circuit No.8 to adjust V<sub>pull</sub> so that the L<sub>X</sub> pin voltage becomes 100mV when the Nch drive Tr is ON and then the voltage at both ends of R<sub>pull</sub> is measured to find the L<sub>X</sub> SW "Nch" ON resistance.

$$R_{LX} = 0.1 / \{(V1 - 0.1) / 4.7\}$$

Note that V1 is the R<sub>pull</sub> previous voltage when the Nch driver Tr is ON. Use an oscilloscope or other instrument to measure the L<sub>X</sub> pin voltage and V1.

## TYPICAL APPLICATION CIRCUIT

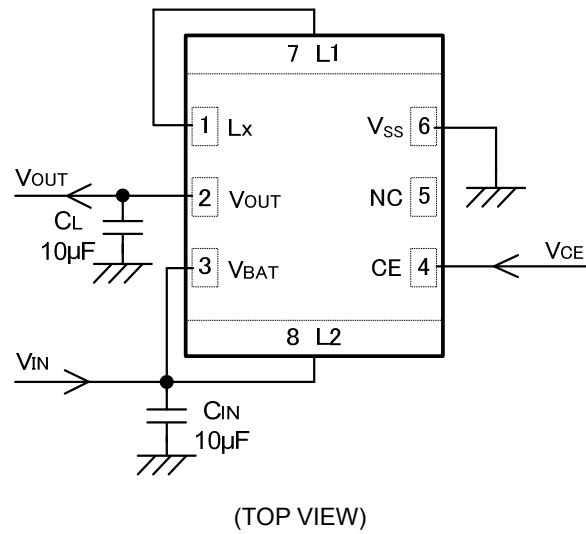

\* The embedded coil is optimized for XCL101 series. Please do not use for other purposes.

### 【Recommended External Components】

	MANUFACTURE	PRODUCT NUMBER	VALUE	L×W (mm)
C <sub>IN</sub> , C <sub>L</sub>	TDK	C1608JB1A106K	10µF/10V	1.60 × 0.80
		C1608X5R1A106K	10µF/10V	1.60 × 0.80
		C2012JB1A106K	10µF/10V	2.00 × 1.25
		C2012X5R106K	10µF/10V	2.00 × 1.25
	TAIYO YUDEN	LMK107BBJ106MALT	10µF/10V	1.60 × 0.80
		LMK212ABJ106KG	10µF/10V	2.00 × 1.25
		LMK212BBJ226MG	22µF/10V	2.00 × 1.25
		JMK212BBJ476MG	47µF/6.3V	2.00 × 1.25



## OPERATION EXPLANATION

The XCL101 Series consists of a standard voltage source, a PFM comparator, a Nch driver Tr, a Pch synchronous rectifier switch Tr, a current sense circuit, a PFM control circuit and a CE control circuit, etc. (refer to the block diagram below.)

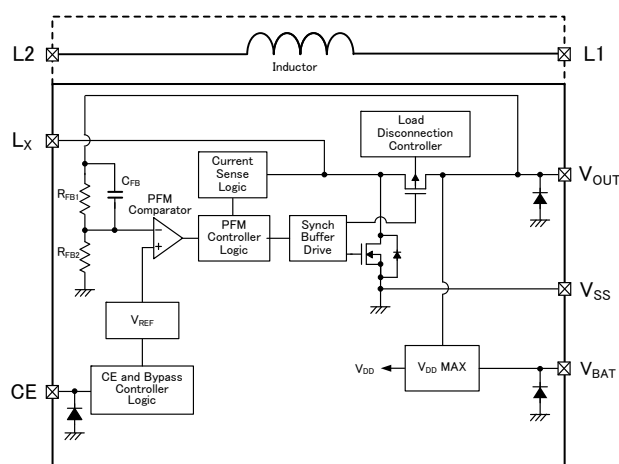

Current limit PFM control is used for the control method to make it difficult for the output voltage ripple to increase even when the switching current is superimposed, so the product can be used within a wide voltage and current range. Further, because PFM control is used, it has excellent transient response to support low capacity ceramic capacitors to realize a compact, high-performance boost DC/DC converter. The synchronous driver and rectifier switch Tr efficiently sends the coil energy to the capacitor connected to the V<sub>OUT</sub> pin to achieve highly efficient operation from low to high loads.

The electrical characteristics actual output voltage V<sub>OUT(E)</sub> is the PFM comparator threshold voltage shown in the block diagram. Therefore, the booster circuit output voltage average value, including the peripheral components, depends on the ripple voltage, so this must be carefully evaluated before being used in the actual product.

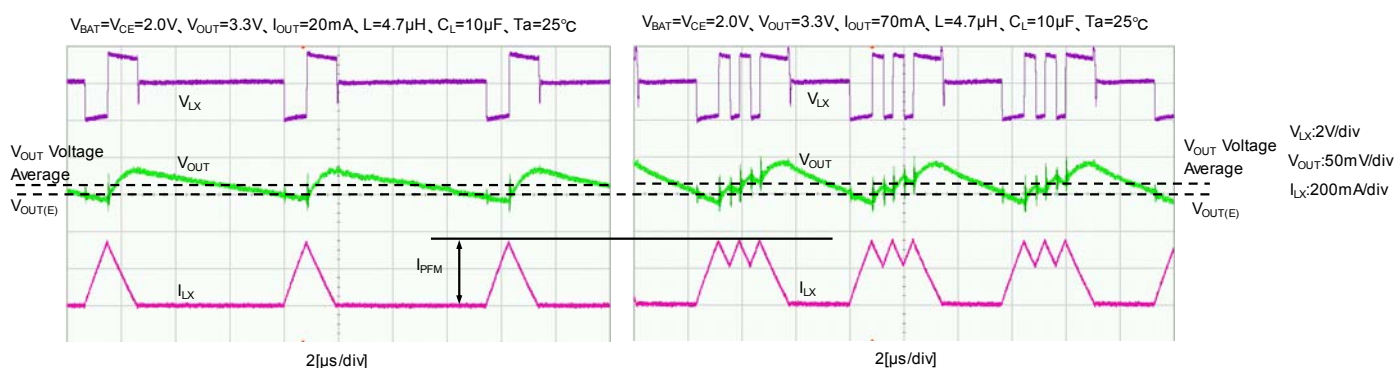

### < Reference Voltage Source (V<sub>REF</sub>) >

The reference voltage source (V<sub>REF</sub> voltage) provides the reference voltage to ensure stable output voltage of the DC/DC converter.

### < PFM Control >

① The voltage from the output voltage divided by the division resistors R<sub>FB1</sub> and R<sub>FB2</sub> in the IC is used as feedback voltage (FB voltage), and the PFM comparator is compared with the FB voltage and V<sub>REF</sub>. If the FB voltage is lower than V<sub>REF</sub>, the signal is sent to the buffer driver via the PFM control circuit and the Nch driver Tr is turned ON. If the FB voltage is higher than V<sub>REF</sub>, the PFM comparator sends a signal that does not turn ON the Nch driver Tr.

② The current sense circuit monitors the current flowing in the Nch driver Tr connected to the Lx pin when the Nch driver Tr is ON. When the prescribed PFM switching current (I<sub>PFM</sub>) is reached, the signal is sent to the buffer driver via the PFM control circuit to turn OFF the Nch driver Tr and turn ON the Pch synchronous rectifier switch Tr.

③ The Pch synchronous rectifier switch Tr ON time (off time) is dynamically optimized internally. After the off time has passed, when the PFM comparator confirms the V<sub>OUT</sub> voltage has exceeded the set voltage, a signal that does not allow the Nch driver Tr to be turned on is sent from the PFM comparator to the PFM control circuit, but if the V<sub>OUT</sub> voltage remains lower than the set voltage, then Nch driver Tr ON is started.

The intervals of the above ①②③ linked operations are continuously adjusted in response to the load current to ensure the output voltage is kept stable from low to high loads and that it is done with good efficiency.

## OPERATION EXPLANATION (Continued)

### <PFM Switching Current>

The PFM switching current unit monitors the current flowing in the Nch driver Tr and functions to limit the current flowing in the Nch driver Tr, but if the load current becomes much larger than the PFM switching energy, the  $V_{OUT}$  voltage becomes lower and prevents the coil current in the Nch driver Tr OFF period from lowering, which affects the internal circuit delay time and results in an excessive current that is larger than the PFM switching current flowing in the Nch driver Tr and Pch synchronous rectifier switch Tr.

### <Load Disconnection Function, Bypass Mode>

When "L" voltage is input to the CE pin, the XCL101A type enters into standby mode and the XCL101C type enters into bypass mode to stop the circuit required for the boost operation. In the standby mode the load cut-off function operates and both the Nch driver Tr and Pch synchronous rectifier switch Tr are turned OFF, which cuts off the current to the  $L_X$  pin and  $V_{OUT}$  pin and the parasitic diode control circuit connects the parasitic diode cathode of the Pch synchronous rectifier switch Tr to the  $L_X$  pin ①. In the bypass mode the Nch driver Tr is OFF, the Pch synchronous rectifier switch Tr is ON when  $V_{LX} > V_{OUT}$ , and the parasitic diode control circuit connects the parasitic diode cathode of the Pch synchronous rectifier switch Tr to the  $V_{OUT}$  pin ②. Also, when  $V_{LX} < V_{OUT}$ , the Pch synchronous rectifier switch Tr is turned OFF and the parasitic diode cathode is connected to the  $V_{OUT}$  pin ②.

Note: Except for the moment when the  $V_{BAT}$  voltage rises up under a start-up condition.

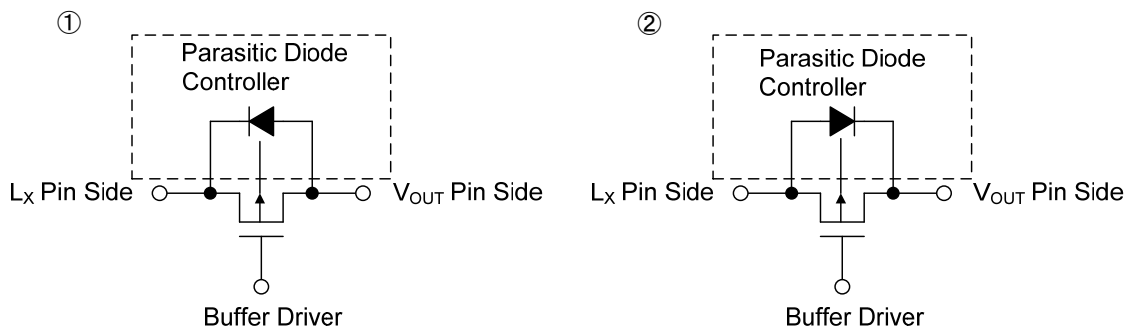

### < $V_{BAT}$ - $V_{OUT}$ Voltage Detection Circuit>

The  $V_{BAT}$ - $V_{OUT}$  voltage detection circuit compares the  $V_{BAT}$  pin voltage with the  $V_{OUT}$  pin voltage, and whichever is the highest is operated to become the IC power supply ( $V_{DD}$ ). In addition, if, during normal operation, the input voltage becomes higher than the output voltage, the Nch driver Tr is turned OFF and the Pch synchronous rectifier switch Tr is kept ON so that the input voltage pass through to the output voltage (through mode). When the input voltage becomes lower than the output voltage, the circuit automatically returns to the normal boost operation. This detection circuit does not operate when in the standby mode.

### <Inrush Current Protection Function>

When the  $V_{BAT}$  or  $V_{CE}$  power supply is input,  $C_L$  is charged via the stable current that results from the inrush current protection function (refer to graphs below). Therefore, this function minimizes potential over current from the  $V_{BAT}$  pin to the  $V_{OUT}$  pin. Also, this current value depends on the  $V_{BAT}$  voltage. After  $C_L$  is charged by the aforementioned stable current and  $V_{OUT}$  reaches around the  $V_{BAT}$  voltage level, the inrush current protection function will be released after several hundred  $\mu s$  ~ several ms and the IC will then move to step-up mode, by pass mode or through mode.

Inrush Current Protection Characteristics

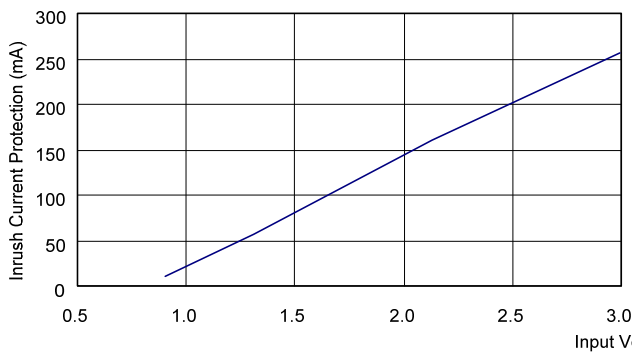

$C_{IN}=4.7 \mu F$  (LMK107BJ475MA)  
 $C_L=10 \mu F$  (LMK107BJ106MA)  
 $I_{OUT}=1mA$ ,  $T_a=25^\circ C$

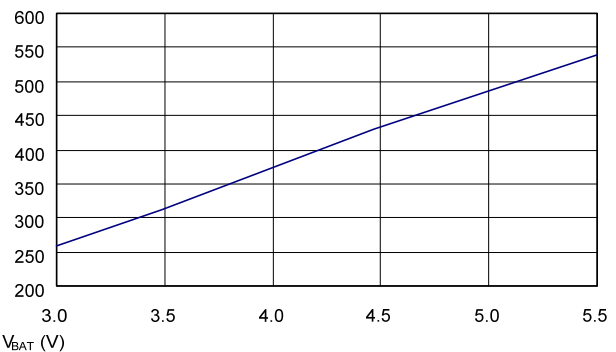

$C_{IN}=4.7 \mu F$  (LMK107BJ475MA)  
 $C_L=10 \mu F$  (LMK107BJ106MA)  
 $I_{OUT}=1mA$ ,  $T_a=25^\circ C$

## NOTE ON USE

1. Be careful not to exceed the absolute maximum ratings for externally connected components and this IC.
2. The DC/DC converter characteristics greatly depend not only on the characteristics of this IC but also on those of externally connected components, so refer to the specifications of each component and be careful when selecting the components. Be especially careful of the characteristics of the capacitor used for the load capacity  $C_L$  and use a capacitor with B characteristics (JIS Standard) or an X7R/X5R (EIA Standard) ceramic capacitor.
3. Use a ground wire of sufficient strength. Ground potential fluctuation caused by the ground current during switching could cause the IC operation to become unstable, so reinforce the area around the GND pin of the IC in particular.
4. Mount the externally connected components in the vicinity of the IC. Also use short, thick wires to reduce the wire impedance.
5. An excessive current that is larger than the PFM switching current flowing in the Nch driver  $T_r$  and Pch synchronous rectifier switch  $T_r$ , which could destroy the IC.
6. When in the bypass mode, the internal Pch synchronous rectifier switch  $T_r$  turns ON to allow current to flow to the Lx pin and  $V_{OUT}$  pin. When an excessive current comes from the  $V_{OUT}$  pin when this bypass operates, it could destroy the Pch synchronous rectifier switch  $T_r$ .
7. The CE pin does not have an internal pull-up or pull-down, etc. Apply the prescribed voltage to the CE pin.
8. The embedded coil is optimized for XCL101 series. Please do not use for other purposes.
9. At high temperatures, the product performance could vary causing the efficiency to decline. Evaluate this carefully before use if the product will be used at high temperatures.
10. Please note that the leak current of the Pch synchronous rectifier switch  $T_r$  during high-temperature standby operation could cause the output voltage to increase.
11. When the voltage difference between  $V_{IN}$  and  $V_{OUT}$  is small, switching energy increases and there is a possibility that the ripple voltage will be too large. And when the ripple voltage becomes big by influence of a load current, please add the  $C_L$  capacitor.
12. When the booster circuit is activated by a low input voltage, during the time until the output voltage reaches about 1.7V, the PFM switching current function might not operate causing the coil current to be superimposed. (See the figure below.)

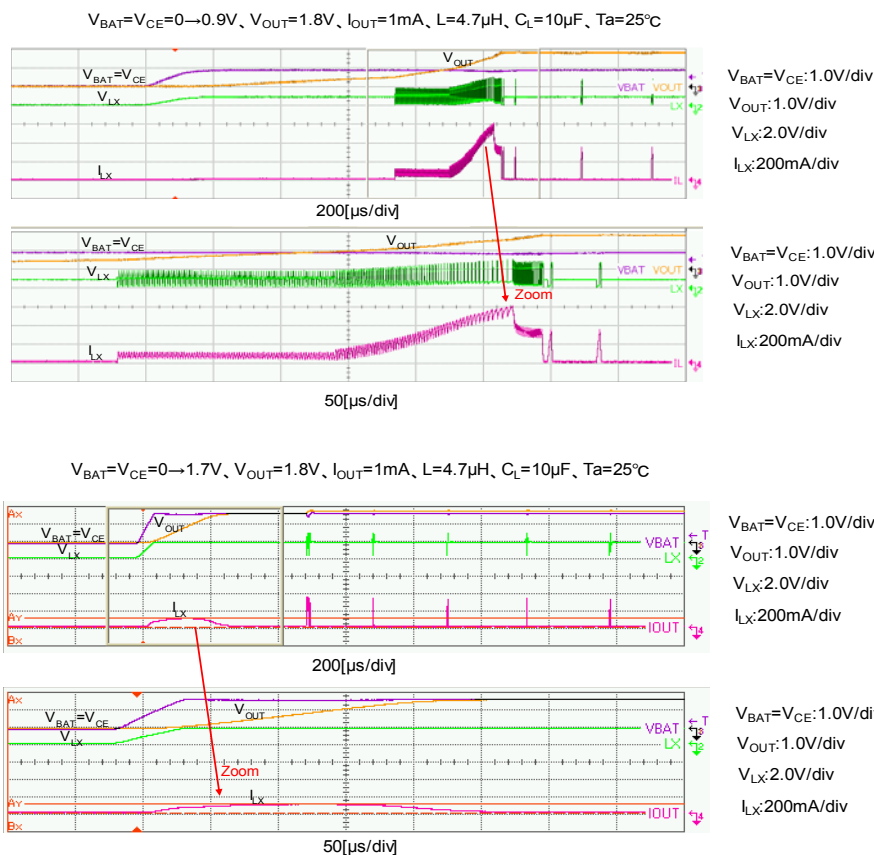

## NOTE ON USE (Continued)

13. If the  $C_L$  capacity or load current becomes excessively large, the output voltage start-up time, when the power is turned on, will increase, so the coil current might be superimposed during the time it takes for the output voltage to become sufficiently higher than the  $V_{BAT}$  voltage.
14. If the input voltage is higher than the output voltage, then the circuit automatically enters the through mode. When the input voltage becomes close to the output voltage, there could be repeated switching between the boost mode and through mode causing the ripple voltage to fluctuate. (Refer to the graphic below)

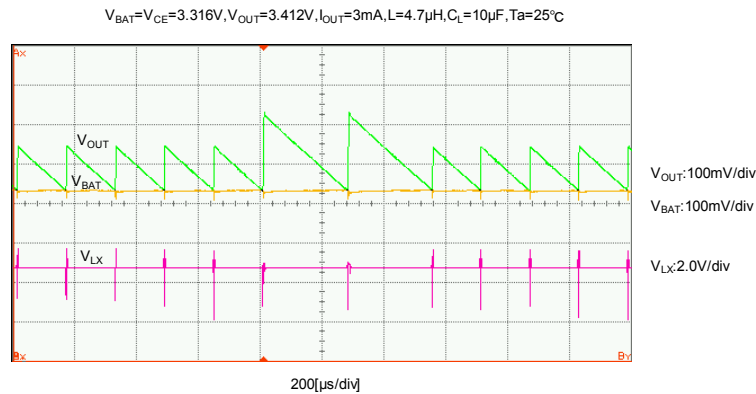

15. If a different power supply is connected from an external source to the XCL101A/XCL101C, the IC could be destroyed.
16. For temporary, transitional voltage drop or voltage rising phenomenon, the IC is liable to malfunction should the ratings be exceeded.
17. Torex places an importance on improving our products and their reliability. We request that users incorporate fail-safe designs and post-aging protection treatment when using Torex products in their systems.
18. With the XCL101A, when the  $V_{BAT}$  or  $V_{CE}$  power supply is input, if the  $V_{OUT}$  pin voltage does not exceed  $V_{BAT} - 0.35V$ , which can happen due to the load current being more than the inrush protection current, step-up mode or through mode operations won't function correctly.
19. With the XCL101C, when the  $V_{BAT}$  power supply is input, if the  $V_{OUT}$  pin voltage does not exceed  $V_{BAT} - 0.35V$ , which can happen due to the load current being more than the inrush protection current, by pass mode operations won't function correctly.

## ■ NOTE ON USE (Continued)

### ● Instruction of pattern layouts

1. In order to stabilize  $V_{BAT}$  voltage level, we recommend that a by-pass capacitor ( $C_{IN}$ ) be connected as close as possible to the  $V_{BAT}$  and ground pins.
2. Please mount each external component as close to the IC as possible.
3. Wire external components as close to the IC as possible and use thick, short connecting traces to reduce the circuit impedance.
4. Make sure that the ground traces are as thick as possible, as variations in ground potential caused by high ground currents at the time of switching may result in instability of the IC.
5. Internal driver transistors bring on heat because of the transistor current and ON resistance of the driver transistors.

### ● Recommended Pattern Layout

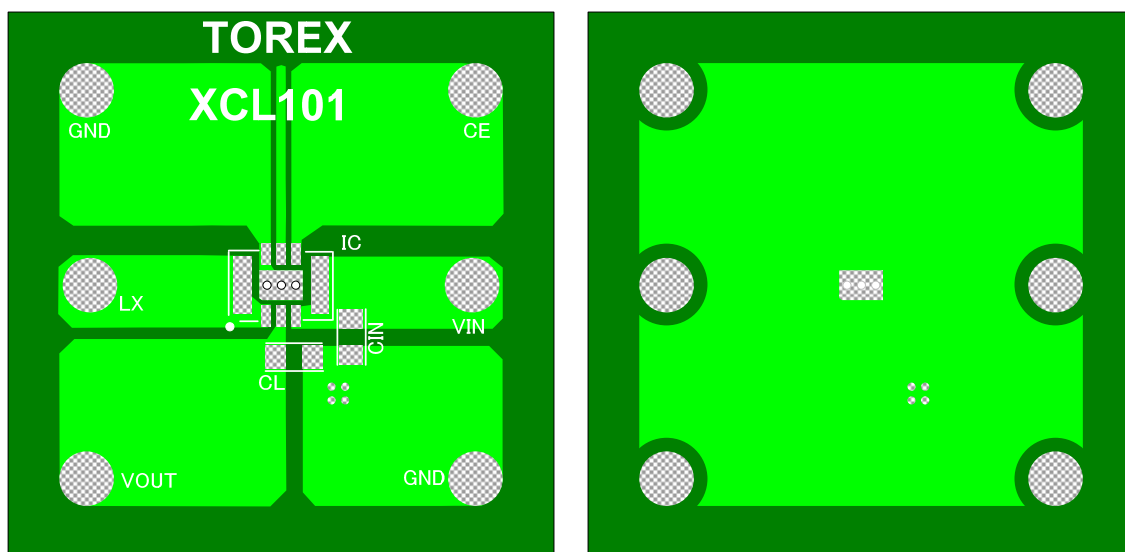

<Top view>

<Bottom view>

## TYPICAL PERFORMANCE CHARACTERISTICS

### 1) Output Voltage vs. Output Current

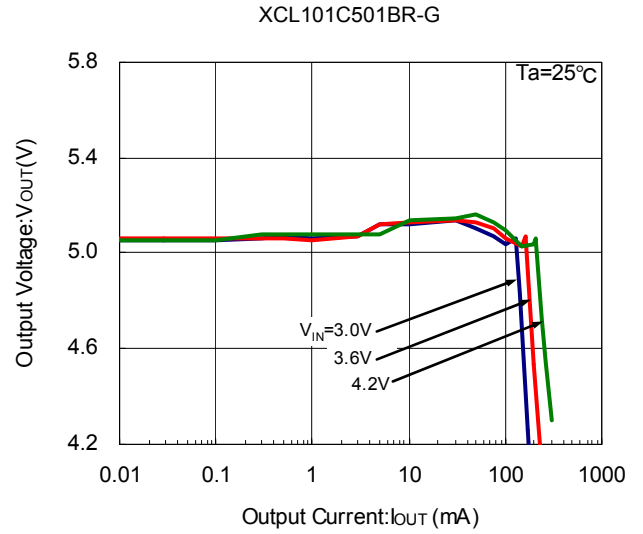
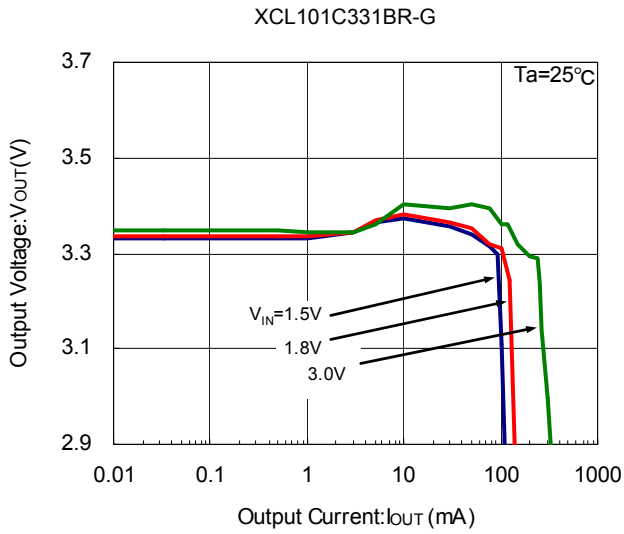

### 2) Efficiency vs. Output Current

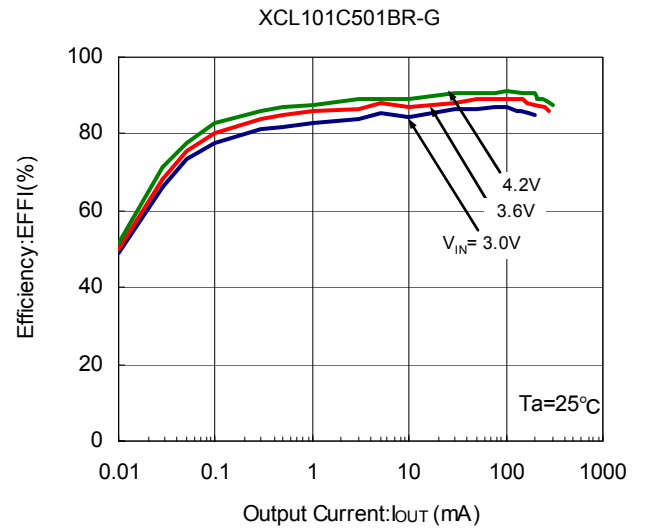
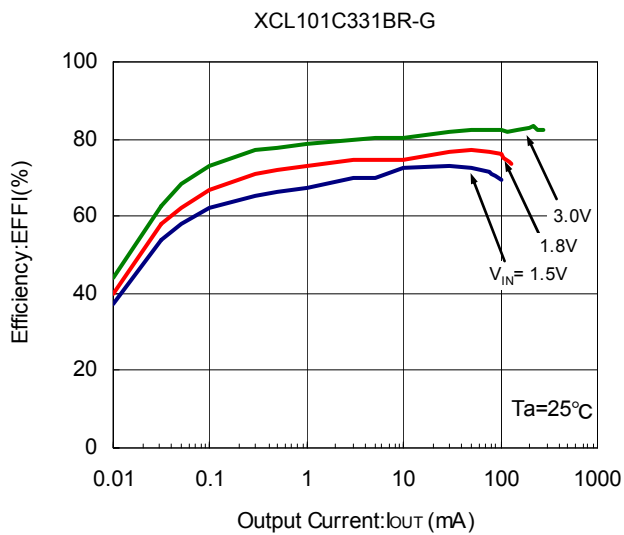

### 3) Ripple Voltage vs. Output Current

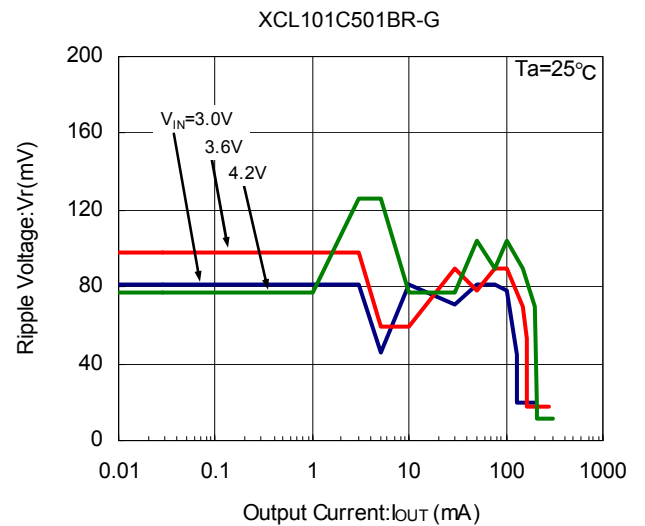
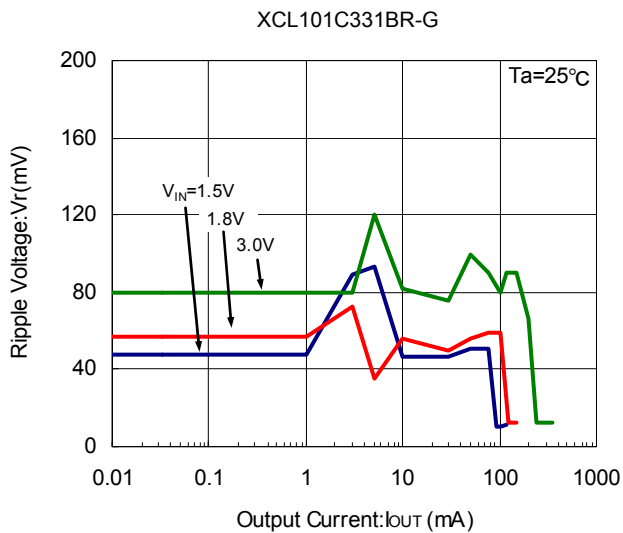

## ■ TYPICAL PERFORMANCE CHARACTERISTICS (Continued)

### 4) Bypass Voltage vs. Output Current

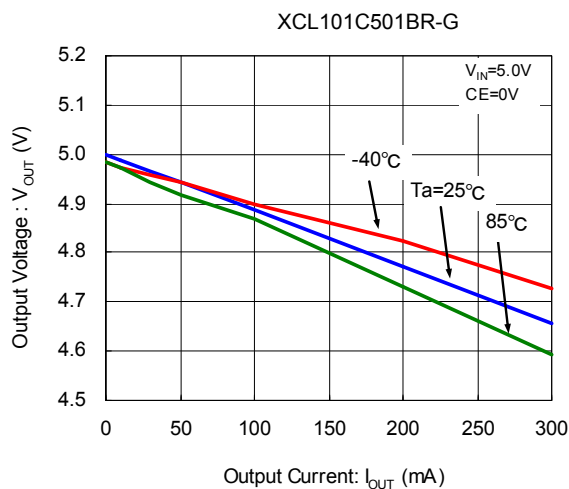
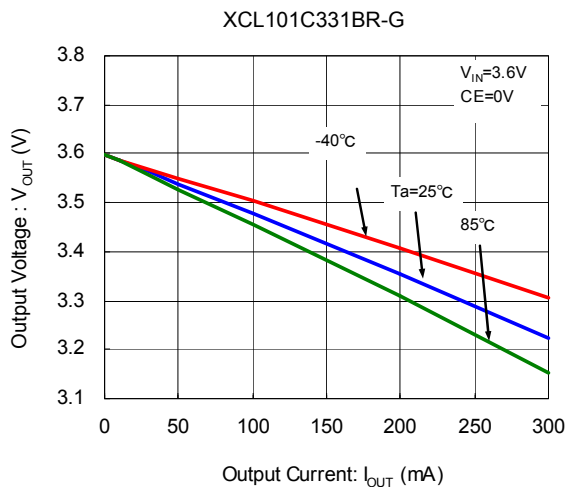

### 5) Load Transient Response

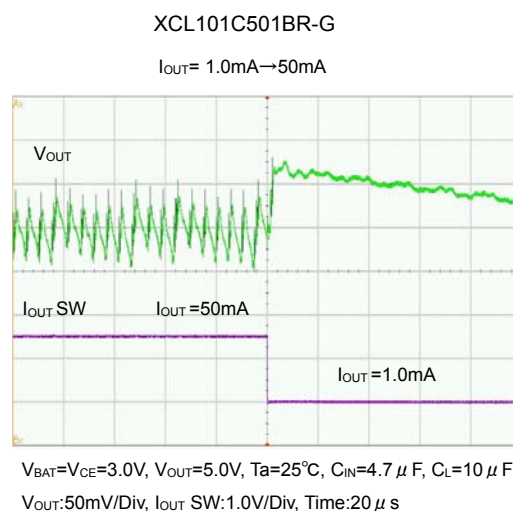
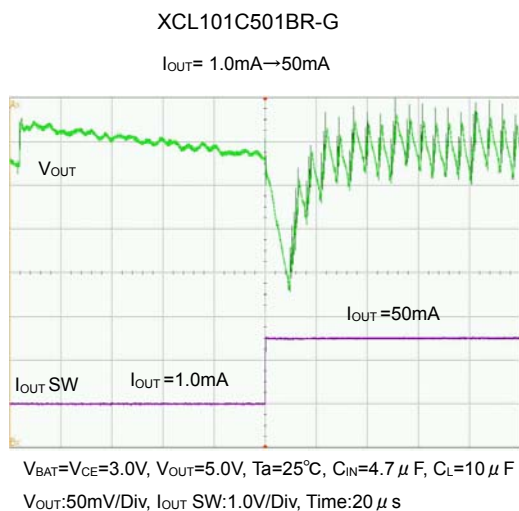
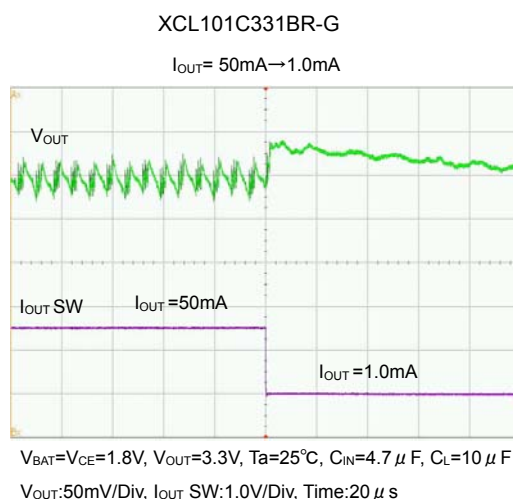
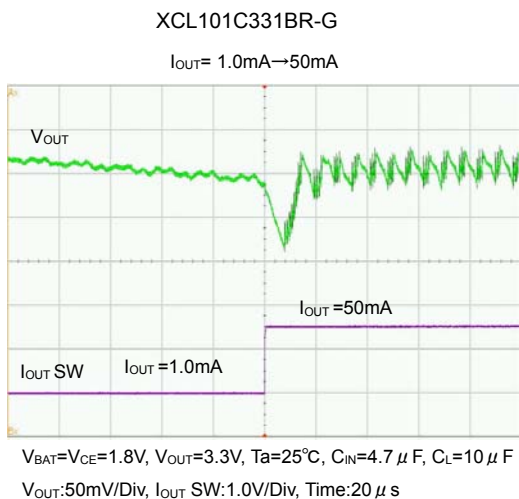







## MARKING RULE

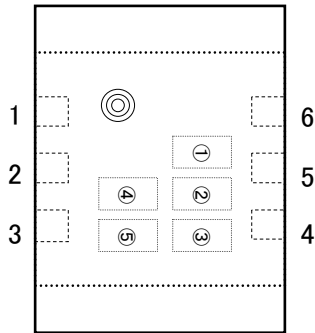

CL-2025/CL-2025-02

① represents products series

MARK	PRODUCT SERIES
1	XCL101*****-G

② represents integer portion of the output voltage

XCL101A\*\*\*\*\*

V <sub>OUT</sub> (V)	MARK
1.x	1
2.x	2
3.x	3
4.x	4
5.x	5

XCL101C\*\*\*\*\*

V <sub>OUT</sub> (V)	MARK
1.x	B
2.x	C
3.x	D
4.x	E
5.x	F

③ represents the decimal part of output voltage

V <sub>OUT</sub> (V)	MARK	PRODUCT SERIES
X.0	0	XCL101**0***-G
X.1	1	XCL101**1***-G
X.2	2	XCL101**2***-G
X.3	3	XCL101**3***-G
X.4	4	XCL101**4***-G
X.5	5	XCL101**5***-G
X.6	6	XCL101**6***-G
X.7	7	XCL101**7***-G
X.8	8	XCL101**8***-G
X.9	9	XCL101**9***-G

Example (mark②, ③)

MARK					
XCL101A33***-G		XCL101C28***-G		XCL101A50***-G	
②	③	②	③	②	③
3	3	C	8	5	0

④, ⑤ represents production lot number

01~09, 0A~0Z, 11~9Z, A1~A9, AA~AZ, B1~ZZ in order.

(G, I, J, O, Q, W excluded)

\* No character inversion used.