

# XDPE15284D Digital Multi-phase Controller

## 8-phase Dual Loop Voltage Regulator

### Features

- Digital controller assisted with high performance analog front ends with a fully programmable ARM® Cortex™ –M0 Processor
- Compliant with Intel™ VR13, VR13HC, and VR14 Server VR Vendor PWM Enabling Specification Rev 1.88 (October 2021)
- Compliant with Intel™ SVID Protocol Spec Rev 1.94 (April 2021)
- Compliant with PMBus Rev 1.3.1 (March 2015) serial interface
  - Query voltage, current, temperature faults
  - Fault Response
  - Maximum supported bus speed 1 MHz
  - Support 1.8/3.3 V operation
- Output voltage regulation range
  - 0.25 V to 1.52 V (5 mV/step)
  - 0.5 V to 3.04 V (10 mV/step)
- Digitally controlled phasing for full flexibility in both loop configuration and phase firing order
- Digital current emulation for TLVR inductor support
- Configurable autonomous phase add/drop
- Automatic phase detection at start-up
- Supports start-up into pre-bias voltage
- Integrated power stage current sense
- Differential output voltage sense
- Fast current balancing with current-mode control
- Digitally programmable PID (Proportional, Integral, Differential) loop compensation
- Digitally programmable loadline slope
- Digital temperature compensation
- Direct input (+12 V) voltage and current sense
- Extensive fault detection and protection capability
  - IUVP, OUV & OOV (fixed and tracking)
  - OCP instantaneous (total current)
  - Multiple OTP thresholds
  - Peak phase current pulse limiting
  - Negative current limit protection
  - TLVR secondary Open/Short detection
- Internal non-volatile memory (NVM) to store multiple custom configurations
- RoHS compliant and Halogen free 40-lead QFN plastic package

# XDPE15284D Digital Multi-phase Controller

## 8-phase Dual Loop Voltage Regulator



### Potential applications

### Potential applications

- Vcore power regulation for Intel™ VR13, VR13HC, VR14 based Microprocessors
  - Servers
  - Workstations
  - High-end desktops
- High Current ASIC, PMBus POLs

### Product validation

Qualified for industrial applications according to the relevant tests of JEDEC47/20/22/78

### Description

The XDPE15284 digital dual loop 8 phase controller provides power for Intel™ VR13, VR13HC, VR14 server, workstation, and high-end desktop applications. Core voltage is provided by a multi-phase buck converter with up to 8 synchronous-rectified channels in parallel while a second loop provides voltage for the I/O. The XDPE15284 phase configuration is flexible in how the phases are allocated to the 2 loops. Any phase can be assigned to either loop and the phase firing order is fully programmable to offer the ultimate in phase configuration flexibility. Typically, configurations of 8+0, 7+1, 6+2, 5+3 or 4+4 phases are supported.

Command and monitoring functions are controlled through the PMBus and SVID interfaces which supports dynamic voltage identification with 5 mV/step or 10 mV/step in Intel mode, output range up to 3.04 V, offset and trim resolution of 625 uV and accuracy better than 0.5%.

The XDPE15284 controller utilizes digital technology to implement all control functions, providing the ultimate system solution in terms of flexibility and stability. Advanced control loop features, such as current mode control, variable frequency operation, Active Transient Response (ATR/FATR), fast DVID response, automatic phase shedding and Pulse Frequency Modulation (PFM) enable optimal response to a highly dynamic load with fast di/dt load transients across a wide range of load current.

The XDPE15284 controller supports multi-vendor pin compatible integrated power stages with trivalent PWM interfaces, fast response, integrated current sense, integrated temperature sense, and advanced fault detection capability, interface and signaling.

In addition to supporting power stage fault protection features, the XDPE15284 controller also includes a set of sophisticated over-voltage, under-voltage, over-temperature, over-current, and phase fault protections. These attributes provide a complete and advanced protection feature set for microprocessor and power systems.

*Infineon strongly recommends pairing Infineon's powerstages with our Digital XDP™ family of controllers to ensure correct interoperability. Interoperability when pairing with other vendor power stages/ discrete power components cannot be guaranteed by Infineon and requires thorough evaluation and characterization by the power stage/ discrete power component vendor.*

**Table 1** Part number and package summary

Part Number	Package
XDPE15284D	40-lead 5 mm x 5 mm QFN PG-VQFN-40

### Table of contents

<b>Features .....</b>	<b>1</b>
<b>Potential applications .....</b>	<b>2</b>
<b>Product validation .....</b>	<b>2</b>
<b>Description .....</b>	<b>2</b>
<b>Table of contents .....</b>	<b>3</b>
<b>1    Ordering information .....</b>	<b>4</b>
<b>2    Package marking .....</b>	<b>5</b>
<b>3    Environmental qualifications .....</b>	<b>6</b>

# 1 Ordering information

**Table 2 Ordering information**

Base Part Number	Package Type	Standard Pack Form and Quantity		Orderable Part Number
XDPE15284D	QFN 5 mm x 5 mm	Tape and Reel	4000	XDPE15284D0000XUMA1 Note 1
				XDPE15284DxyzzXUMA1 Note 2

Note:

1. Standard Part Number with default configuration
2. Customer Specific Part Number, where x = Firmware ID, and yzz = Custom Config File ID (Codes assigned by Product Marketing).

## Sample Programming

The customer can program the parts to their specific system requirements using software/hardware available from Infineon or through other controller programming 3<sup>rd</sup> Parties (contact Infineon for recommendations). Infineon Field Application Engineers are available to assist with system and configuration file optimization and programming of the controllers. Alternatively, samples can be ordered with a customer specific configuration pre-programmed at the factory, but lead times for these types of samples are significantly longer than for standard default configuration samples. The generic part numbering format is shown below:

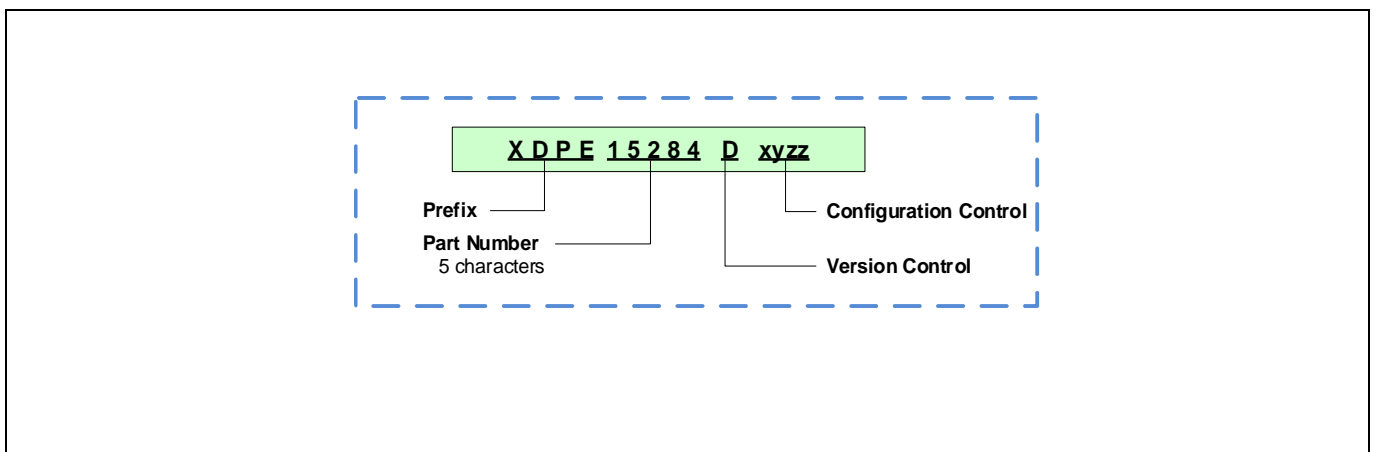

**Figure 1 Part number decoding**

## 2 Package marking

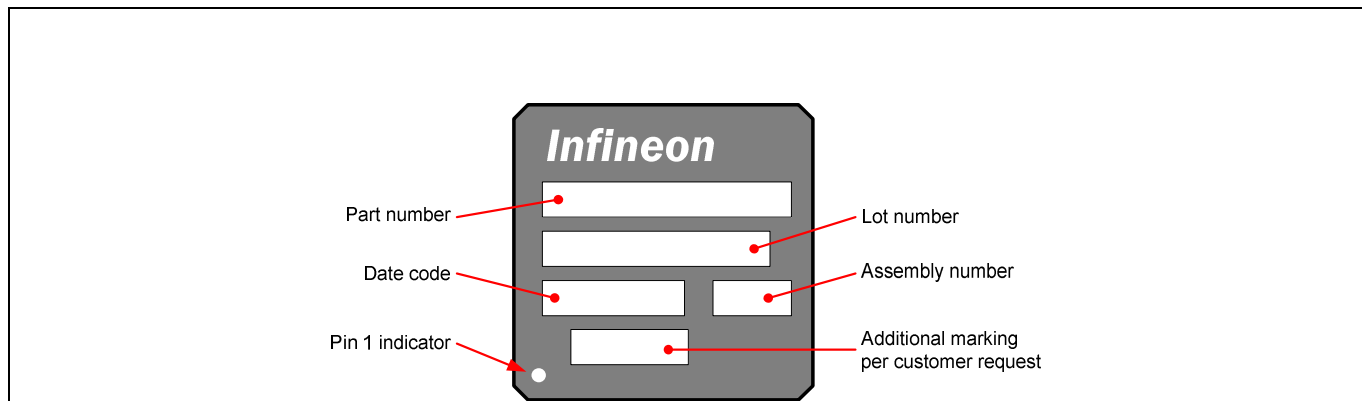

**Figure 2** Package marking

### 3 Environmental qualifications

**Table 3**

<b>Qualification Level</b>		Industrial	
<b>Moisture Sensitivity</b>		QFN Package	MSL3
<b>ESD</b>	Human Body Model	JESD22-A114-F, Class 2	
	Charged Device Model	JESD22-C101-F, Class C3	
	Latch-up	JESD78D Class 2	
<b>RoHS Compliant</b>		Yes	