



xPico® Embedded Device Server Integration Guide

Intellectual Property

© 2017 Lantronix, Inc. All rights reserved. No part of the contents of this publication may be transmitted or reproduced in any form or by any means without the written permission of Lantronix.

Lantronix, *xPico* and *DSTni* are registered trademarks of Lantronix, Inc. in the United States and other countries. *DeviceInstaller* is a trademark of Lantronix, Inc.

Patented: <http://patents.lantronix.com>; additional patents pending.

Wi-Fi is a registered trademark of Wi-Fi Alliance Corporation. *Ethertronics* is a trademark of Ethertronics, Inc. *Wanshih* is a trademark of Wanshih Electronic Co., Ltd. *Exar* is a trademark of Exar Corporation. *SEMTECH* is a trademark of Semtech Corporation. All other trademarks and trade names are the property of their respective holders.

Contacts

Lantronix, Inc.

7535 Irvine Center Drive
Suite 100
Irvine, CA 92618, USA
Toll Free: 800-526-8766
Phone: 949-453-3990
Fax: 949-453-3995

Technical Support

Online: www.lantronix.com/support

Sales Offices

For a current list of our domestic and international sales offices, go to the Lantronix web site at www.lantronix.com/about/contact

Disclaimer

All information contained herein is provided “AS IS.” Lantronix undertakes no obligation to update the information in this publication. Lantronix does not make, and specifically disclaims, all warranties of any kind (express, implied or otherwise) regarding title, non-infringement, fitness, quality, accuracy, completeness, usefulness, suitability or performance of the information provided herein. Lantronix shall have no liability whatsoever to any user for any damages, losses and causes of action (whether in contract or in tort or otherwise) in connection with the user’s access or usage of any of the information or content contained herein. The information and specifications contained in this document are subject to change without notice.

This equipment has been tested and found to comply with the limits for a Class B digital device, pursuant to Part 15 of the FCC Rules. These limits are designed to provide reasonable protection against harmful interference in a residential installation. This equipment generates, uses, and can radiate radio frequency energy and, if not installed and used in accordance with the instructions, may cause harmful interference to radio communications. However, there is no guarantee that interference will not occur in a particular installation. If this equipment does cause harmful interference to radio or television reception, which can be determined by turning the equipment off and on, the user is encouraged to try to correct the interference by one of the following measures:

1. Reorient or relocate the receiving antenna.
2. Increase the separation between the equipment and receiver.
3. Connect the equipment into an outlet on a circuit different from that to which the receiver is connected.
4. Consult the dealer or an experienced radio/TV technician for help.

This device complies with Part 15 of the FCC Rules. Operation is subject to the following two conditions: (1) This device may not cause harmful interference, and (2) this device must accept any interference received, including interference that may cause undesired operation.

This device is intended only for OEM Integrators. The OEM integrator should be aware of the following important issues.

Labeling of the End Product (xPico Wi-Fi units only)

The label on the end product incorporating the xPico Wi-Fi module must clearly state that it contains an FCC-approved RF module. Canada and Japan also require a similar statement.

For example, "This product contains RF transmitter ID # (put FCC, IC, and/or Japan module grant numbers here)." The label must include the ID numbers for the regions where the end product is installed. The grant numbers are below.

- ◆ xPico Wi-Fi FCC ID number: R68XPICOW
- ◆ xPico Wi-Fi IC ID number: 3867A-XPICOW
- ◆ xPico Wi-Fi Japan ID numbers: 201-135275

RSS-GEN Sections 7.1.4 and 7.1.5 Statement for Devices with Detachable Antennas (xPico Wi-Fi units only)

This device has been designed to operate with the antennas listed in the Certificate, and having a maximum gain of 2.88 dBi. Antennas not included in this list or having a gain greater than 2.88 dBi are strictly prohibited for use with this device, unless system level FCC approval is gained. The required antenna impedance is 50 ohms.

To reduce potential radio interference to other users, the antenna type and its gain should be so chosen that the equivalent isotropically radiated power (EIRP) is not more than that required for successful communication.

Integration Notes (xPico Wi-Fi embedded device server):

- ◆ *This module is authorized under limited module approval specified to mobile host equipment. So, the antenna must be installed such that 20cm is maintained between the antenna and users.*
- ◆ *The transmitter module may not be co-located with any other transmitter or antenna.*
- ◆ *As long as the two conditions above are met, further transmitter testing will not be required. However, the OEM integrator is still responsible for testing their end product for any additional compliance requirements required with this module installed (for example, digital device emission, PC peripheral requirements, etc.)*
- ◆ *In the event that these conditions cannot be met (for example certain laptop configurations, general purpose PCMCIA or similar cards, or co-location with another transmitter) and obtaining a separate FCC authorization will be required, then the FCC authorization is no longer considered valid and the FCC ID cannot be used on the final product (including the transmitter).*
- ◆ *Changes or modifications to this device not explicitly approved by Lantronix will void the user's authority to operate this device.*

Note: With the purchase of any xPico family product, the OEM agrees to an OEM firmware license agreement that grants the OEM a non-exclusive, royalty-free firmware license to use and distribute the binary firmware image provided, only to the extent necessary to use the xPico hardware. For further details, please see the xPico OEM firmware license agreement.

Warranty

For details on the Lantronix warranty policy, please go to our Web site at www.lantronix.com/support/warranty.

Revision History

Date	Rev.	Comments
April 2012	A	Initial release.
September 2012	B	Updated the reference schematic, mounting instructions and compliance information.
January 2013	C	Updated xPico pin-out diagram.
July 2013	D	Updated to include xPico Wi-Fi part information.
August 2013	E	Updated to include Japanese certification number.
January 2014	F	Updated reference schematic information.
February 2014	G	Updated for firmware version 1.1.0.2R10.
June 2014	H	Updated Lantronix part number information.
December 2014	I	Updated for firmware version 1.3.0.1.
May 2015	J	Updated diagram dimensions and RX sensitivity information. Added ISO/IEC Compliance information.
December 2015	K	Updated part number and module dimension information.
September 2017	L	Updated compliance information.

For the latest revision of this product document, please check our online documentation at www.lantronix.com/support/documentation.

Table of Contents

Intellectual Property	2
Contacts	2
Disclaimer	2
Warranty	4
Revision History	4
List of Figures	6
List of Tables	7
1. Introduction	8
About the Integration Guide	8
Additional Documentation	9
2. Functional Description	10
xPico Features	11
xPico Wi-Fi Features	11
xPico Block Diagram	13
xPico Wi-Fi Block Diagram	14
PCB Interface	15
Mating Connector	19
Antenna Interface (xPico Wi-Fi Units Only)	19
Antenna Placement (xPico Wi-Fi Units Only)	21
Ethernet Interface (xPico Wired Units Only)	21
Serial Interface	23
USB Device Port (xPico Wi-Fi Units Only)	25
LEDs	26
General Purpose I/O Pins	26
Reset Pins	27
Evaluation Board Schematics	28
3. Mounting Instructions and PCB Footprint	33
To Access CAD Files	33
To Install the xPico or xPico Wi-Fi Module	33
Product Information Label	38
4. Specifications	39
Electrical Specifications	39
Technical Specifications	41
A: Compliance (xPico Embedded Device Server)	44
B: Compliance (xPico Wi-Fi Embedded Device Server)	46

List of Figures

Figure 2-1 xPico and xPico Wi-Fi Dimensions and Views _____	12
Figure 2-2 xPico Block Diagram _____	13
Figure 2-3 xPico Wi-Fi Block Diagram _____	14
Figure 2-4 Reverse-SMA to U.FL(long) (Lantronix Part Number 500-180-R) _____	20
Figure 2-5 U.FL to U.FL Cable (Lantronix Part Number 500-181-R) _____	20
Figure 2-6 Reverse-SMA to U.FL(short) (Lantronix Part Number 500-182-R) _____	21
Figure 2-7 Ethernet Connection Example (xPico wired unit only) _____	23
Figure 2-8 Serial Port Example _____	24
Figure 2-9 USB Device Interface Example (xPico Wi-Fi unit only) _____	25
Figure 2-10 Evaluation Board Schematic, Part 1 of 5 _____	28
Figure 2-11 Evaluation Board Schematic, Part 2 of 5 _____	29
Figure 2-12 Evaluation Board Schematic, Part 3 of 5 _____	30
Figure 2-13 Evaluation Board Schematic, Part 4 of 5 _____	31
Figure 2-14 Evaluation Board Schematic, Part 5 of 5 _____	32
Figure 3-1 White Mounting Quick Clip Dimensions _____	33
Figure 3-2 Aligning Mounting Clip Legs to Standoff Holes _____	35
Figure 3-3 Mounting Instructions for PEM Standoff _____	36
Figure 3-4 Hirose Connector Layout _____	37
Figure 3-5 xPico Product Label _____	38
Figure 3-6 xPico Wi-Fi Product Label _____	38
Figure A-1 Certificate of Compliance for Halogen Free _____	45

List of Tables

Table 1-1 xPico and xPico Wi-Fi Features _____	8
Table 2-1 xPico Part Numbers _____	10
Table 2-2 xPico and xPico Wi-Fi Pin Connections _____	15
Table 2-3 xPico (wired) PCB Interface Signals _____	16
Table 2-4 xPico Wi-Fi PCB Interface Signals _____	17
Table 2-5 xPico Wi-Fi External Antenna Options _____	19
Table 2-6 Ethernet Interface Signals _____	21
Table 2-7 Recommended Magnetic Modules and Combo RJ45/Magnetic Module Connectors _____	22
Table 2-8 xPico and xPico Wi-Fi Serial Port Signals _____	23
Table 2-9 RS232 Connections (Serial Transceiver Required) _____	24
Table 2-10 RS422/485 Connections (Serial Transceiver Required) _____	24
Table 2-11 USB Host Port Signals _____	25
Table 2-12 xPico Wi-Fi Status LED Output Signals _____	26
Table 2-13 xPico Status LED Output Signals _____	26
Table 2-14 Ethernet Interface xPico Serial Port Signals _____	26
Table 2-15 xPico Reset Signals _____	27
Table 4-1 Absolute Maximum Ratings _____	39
Table 4-2 xPico Wired Recommended Operating Conditions _____	39
Table 4-3 xPico Wi-Fi Recommended Operating Conditions _____	40
Table 4-4 xPico Wired Technical Specification _____	41
Table 4-5 xPico Wi-Fi Technical Specification _____	42
Table A-1 Electromagnetic Emissions _____	44
Table A-2 Electromagnetic Immunity _____	44

1. Introduction

About the Integration Guide

This user guide provides the information needed to integrate the Lantronix® xPico® embedded device servers into customer-printed circuit boards. This manual is intended for engineers responsible for integrating the xPico embedded device server into their product.

Note: This document includes support for xPico embedded device server versions XPC100100B-01, XPC100100S-01, XPC100100K-02, XPC10010MB-01 and XPC10010MS-01, and xPico Wi-Fi embedded device server versions XPW100100B-01, XPW100100S-01 and XPW100100K-02. For integration information for the Lantronix xPico Wi-Fi SMT embedded device server modules, XPCW1002 and XPC@10003, please reference document 900-714 xPico Wi-Fi SMT Embedded Device Server Integration Guide.

The sections in chapter 2 provide board schematic and layout recommendations for both xPico (wired) and xPico Wi-Fi® products. Some of the sections apply to xPico (wired) only or xPico Wi-Fi units only. Signals that are unused for a particular product can be left floating. If the application has the potential to use both components as a stuff option it is recommended to follow the design guide for all of the sections. The table below lists which sections are applicable to the xPico (wired) and xPico Wi-Fi products.

Note: “xPico” (wired) refers to the Ethernet-only versions of xPico embedded device server.

Table 1-1 xPico and xPico Wi-Fi Features

Chapter 2 Section	xPico (wired)	xPico Wi-Fi
PCB Interface	X	X
Mating Connector	X	X
Antenna Interface		X
Antenna Placement		X
Ethernet Interface	X	
Serial Interface	X	X
USB Device Port		X
LEDs	X	X
General Purpose IO Pins	X	X
Reset Pins	X	X
Reference Schematic	X	X

Additional Documentation

Visit the Lantronix web site at www.lantronix.com/support/documentation for the latest documentation and the following additional documentation.

Document	Description
<i>xPico Wi-Fi SMT Embedded Device Server User Guide</i>	Datasheet for the xPico Wi-Fi W1002 and W1003 SMT modules.
<i>xPico Embedded Device Server User Guide</i>	Provides information needed to configure, use, and update the xPico firmware.
<i>xPico Wi-Fi Embedded Device Server User Guide</i>	Provides information needed to configure, use, and update the xPico Wi-Fi firmware.
<i>xPico Embedded Device Server Development Kit Quick Start</i>	Provides the steps for getting the xPico device server up and running.
<i>xPico Embedded Device Server Development Kit User Guide</i>	Provides a detailed description of the xPico evaluation kit hardware
<i>APS: Modbus Protocol User Guide</i>	Provides detailed information for installing and operating the IAP device server using our Modbus firmware.
<i>DeviceInstaller™ User Guide</i>	Provides instructions for using the Windows® based utility to configure the xPico and other Lantronix device servers.
<i>Com Port Redirector User Guide</i>	Provides information on using the Windows based utility to create a virtual com port.

2. Functional Description

Designed for quick integration with minimal engineering effort, the chip-sized xPico embedded device server provides simplicity and flexibility making it the easiest and fastest networking-enabling module on the market.

xPico and xPico Wi-Fi device servers are extremely compact networking solution that enables Ethernet or Wireless connectivity on virtually any device with a serial interface. The included industry-proven Lantronix device server application and full IP stack allow seamless remote access to device data simplifying design integration while providing robust connectivity.

As one of the smallest embedded device servers in the world, xPico and xPico Wi-Fi embedded device servers can be utilized in designs typically intended for chip solutions. A key difference with the xPico device server is that there is virtually no need to write a single line of code, translating to a much lower development cost and faster time-to-market.

Table 2-1 xPico Part Numbers

Part Number	Description
XPC100100B-01	xPico Device Server Module, Extended Temp, AES Encryption, Bulk, RoHS
XPC100100S-01	xPico Device Server Module, Extended Temp, AES Encryption, Sample, RoHS
XPC100100K-02	xPico Device Server Module Development Kit w/ Module, RoHS
XPW100100B-01	xPico Wi-Fi — IEEE 802.11 b/g/n Device Server Module, Extended Temp, Bulk, RoHS
XPW100100S-01	xPico Wi-Fi — IEEE 802.11 b/g/n Device Server Module, Extended Temp, Sample, RoHS
XPW100100K-01	xPico Wi-Fi — IEEE 802.11 b/g/n Device Server Development Kit w/ Module, RoHS
XPC10010MB-01	xPico IAP Device Server Module, Extended Temperature, Modbus, RoHS, Bulk
XPC10010MS-01	xPico IAP Device Server Module, Extended Temperature, Modbus, RoHS, Sample

xPico Features

The xPico device server contains Lantronix's own DSTni® EX controller, with 256 KBytes of SRAM, 16 KBytes of boot ROM, and integrated 10/100 PHY.

The xPico embedded device server also contains the following:

- ◆ 3.3-volt serial interface
- ◆ 8 Configurable I/O pins
- ◆ All logic level I/O pins are 5V input tolerant
- ◆ 4-Mbit flash memory
- ◆ Power supply filters
- ◆ Reset circuit
- ◆ +1.8V regulator

Note: *The xPico embedded device server does not contain integrated Ethernet magnetics. An external Ethernet magnetic module and RJ45 Jack is required to interface to a standard 10/100Mbps Ethernet network.*

The xPico unit requires +3.3-volt power and is designed to operate in an extended temperature range (see technical data).

xPico Wi-Fi Features

The xPico Wi-Fi device server contains Cortex M3 ARM processor with 128KByte of SRAM and 1MByte of embedded Flash memory. The unit also includes an 802.11 b/g/n WLAN radio with a U.FL port for connection to an external antenna.

The xPico Wi-Fi embedded device server also contains the following:

- ◆ 3.3-volt serial interface
- ◆ 8 Configurable I/O pins
- ◆ All logic level I/O pins are 5V input tolerant
- ◆ 8-Mbit flash memory (in addition to the 1MByte CPU embedded Flash)
- ◆ Power supply filters
- ◆ Reset circuit

Note: *xPico Wi-Fi units do not contain an integrated antenna. An external antenna is required for connection to a WLAN network.*

The xPico Wi-Fi embedded device server requires +3.3-volt power and is designed to operate in an extended temperature range (see technical data).

Figure 2-1 xPico and xPico Wi-Fi Dimensions and Views

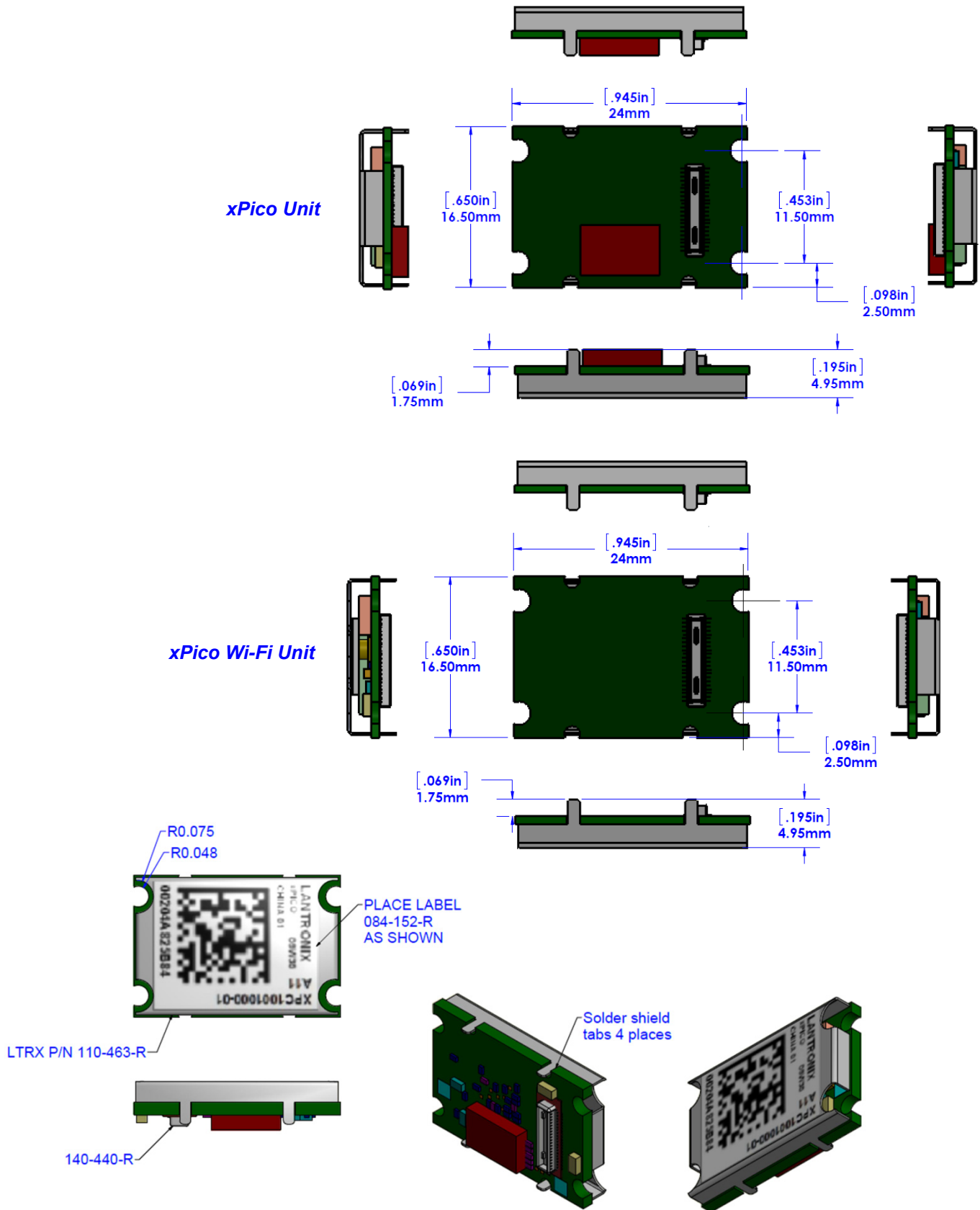

xPico Block Diagram

The following drawing is a block diagram of the xPico embedded device server showing the relationships of the components.

Figure 2-2 xPico Block Diagram

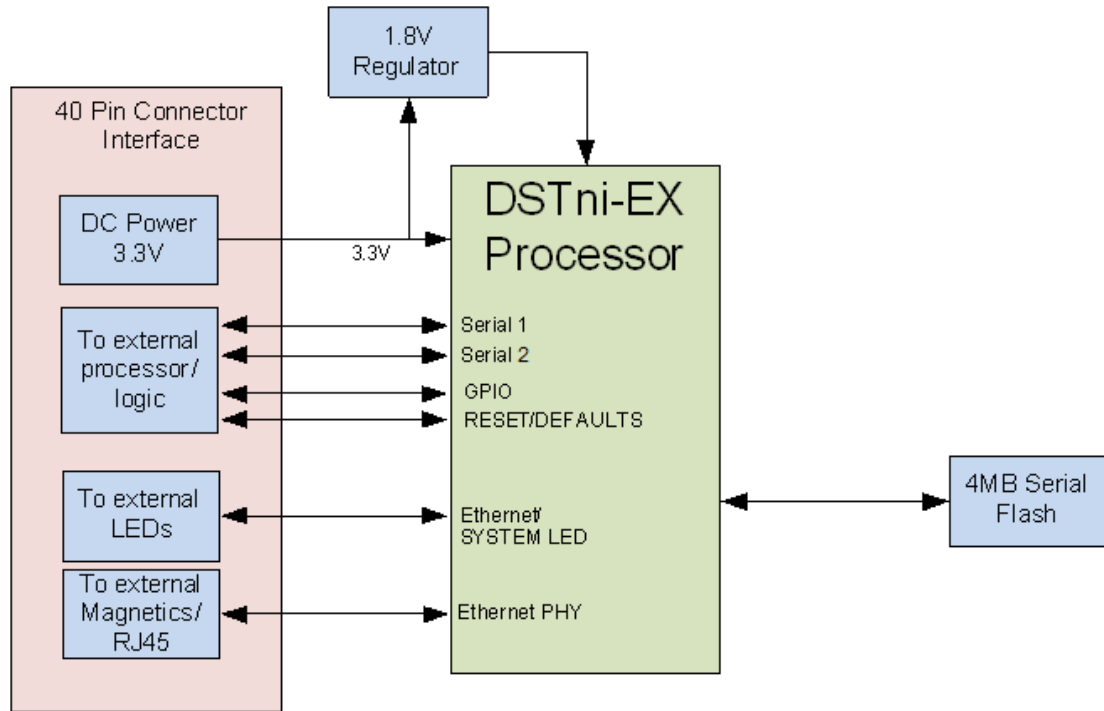

xPico Wi-Fi Block Diagram

The following drawing is a block diagram of the xPico Wi-Fi embedded device server showing the relationships of the components.

Figure 2-3 xPico Wi-Fi Block Diagram

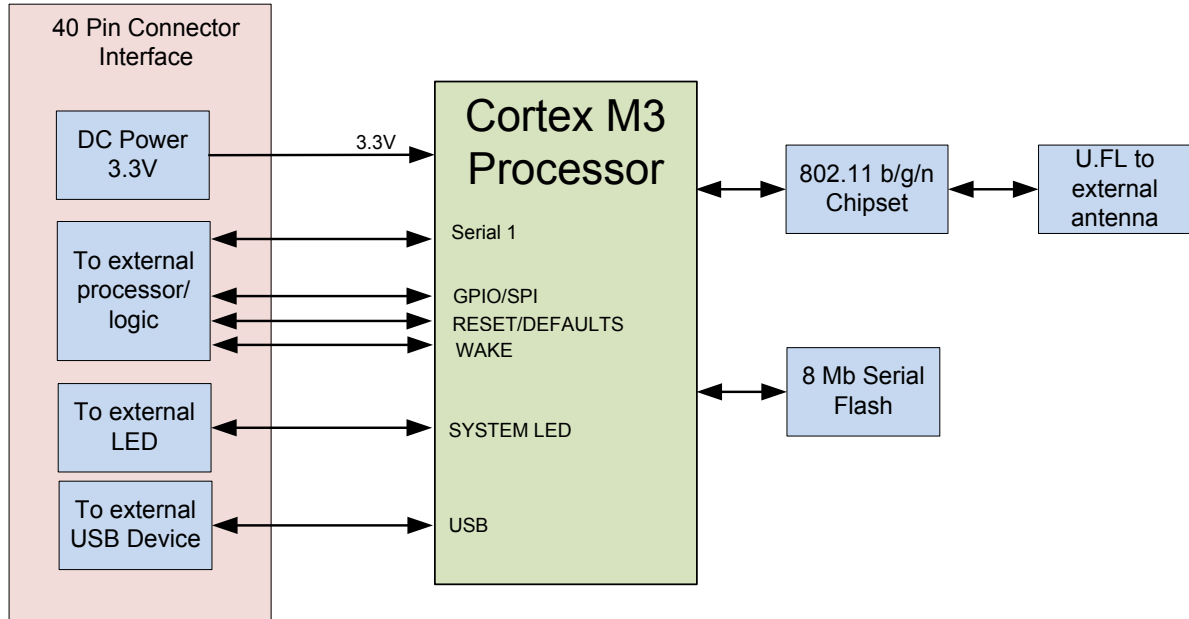

PCB Interface

The xPico embedded device servers has a serial interface compatible with data rates up to 921,600 bps (in high-performance mode). The serial signals (RX, TX, RTS, CTS, and all CPs) are 3.3V CMOS logic level and 5V tolerant. The serial interface pins include +3.3V, ground, and reset. The serial signals usually connect to an internal device, such as a UART. For applications requiring an external cable running with RS-232 or RS422/485 voltage levels, the xPico device must interface to a serial transceiver chip. All configurable I/O pins are 3.3V CMOS logic level and 5V input tolerant. The xPico unit requires a mating connector. Customers should layout their PCB for Hirose part number DF40C(2.0)-40DS-0.4V(51).

An external Ethernet magnetic module and RJ45 is required to interface the xPico embedded device server to a standard 10/100Mbps Ethernet network.

An external antenna attached to the xPico Wi-Fi U.FL connector is required to connect to an 802.11b/g/n wireless network.

Shown below is the xPico pin connection diagram highlighting the differences between the xPico and xPico Wi-Fi embedded device server.

Table 2-2 xPico and xPico Wi-Fi Pin Connections

Pin#	xPico Wired	xPico Wi-Fi	Pin#	xPico Wired	xPico Wi-Fi
1	GND	GND	2	GND	GND
3	CP8	CP8/SPI_CS	4	LED1/LINK	LED1/WLAN_LED
5	RTS1	RTS1	6	LED0/SPEED	NC
7	RXD1	RXD1	8	LED2/ACTIVITY	NC
9	GND	GND	10	TXD1	TXD1
11	ETX-	NC	12	ETCT	NC
13	ETX+	NC	14	LED3/DUPLEX(OUT)	WKUP (IN)
15	GND	GND	16	CTS1	CTS1
17	ERX-	NC	18	ERCT	NC
19	ERX+	NC	20	SYS_LED	SYS_LED
21	GND	GND	22	Reserved	DDP
23	RXD2	RXD2	24	Reserved	DDM
25	TXD2	TXD2	26	CP2/INT	CP2/SPI_INT
27	CP7	CP7/SPI_SCK	28	CP3	CP3/MISO
29	+3.3V	+3.3V	30	CP4	CP4/MOSI
31	+3.3V	+3.3V	32	CP5	CP5
33	+3.3V	+3.3V	34	CP6	CP6
35	CP1	CP1	36	DEFAULT#(IN)	DEFAULT#(IN)
37	GND	GND	38	EXT_RESET#(IN)	EXT_RESET#(IN)
39	GND	GND	40	GND	GND

Table 2-3 xPico (wired) PCB Interface Signals

Signal Name	xPico Pin #	Primary Function	Reset State	Internal Pull-up	Driver Strength
GND	1	Signal Ground			
GND	2	Signal Ground			
CP8	3	Configurable I/O	Input	Active 56K to 122K	4mA
LED1/LINK	4	Ethernet Link LED, active low	Output		8mA
RTS1	5	Serial ready to send/ serial transmit enable	Output		2mA
LED0/SPEED	6	Ethernet speed LED, active low	Output		8mA
RXD1	7	Serial receive data input 1	Input	Active 56K to 122K	
LED2/ACTIVITY	8	Ethernet Activity LED, active low	Output		8mA
GND	9	Signal Ground			
TXD1	10	Serial transmit data output 1	Output		2mA
TX-	11	Ethernet transmit differential (neg)	Output		
TCT	12	Ethernet transmit center tap			
TX+	13	Ethernet transmit differential (pos)	Output		
LED3/DUPLEX	14	Ethernet Duplex LED, active low	Output		8mA
GND	15	Signal Ground			
CTS1	16	Serial Clear to Send	Input	Active 56K to 122K	
RX-	17	Ethernet receive differential (neg)	Input		
RCT	18	Ethernet receive center tap			
RX+	19	Ethernet receive differential (pos)	Input		
SYSTEM_LED	20	System status LED, active high	Input	Active 56K to 122K	4mA
GND	21	Signal Ground			
Reserved	22	Reserved for future use. Do not connect.			
RXD2	23	Serial receive data input 2	Input	Active 56K to 122K	
Reserved	24	Reserved for future use. Do not connect.			
TXD2	25	Serial transmit data output 2	Output		2mA
CP2/INT	26	Configurable I/O-External interrupt input	Input	Active 56K to 122K	4mA

Signal Name	xPico Pin #	Primary Function	Reset State	Internal Pull-up	Driver Strength
CP7	27	Configurable I/O	Input	Active 56K to 122K	4mA
CP3	28	Configurable I/O	Input	Active 56K to 122K	4mA
3V3	29	3.3V Input Power			
CP4	30	Configurable I/O	Input	Active 56K to 122K	4mA
3V3	31	3.3V Input Power			
CP5	32	Configurable I/O	Input	10K	4mA
3V3	33	3.3V Input Power			
CP6	34	Configurable I/O	Input	10K	4mA
CP1	35	Configurable I/O	Input	Active 56K to 122K	4mA
DEFAULT#	36	Unit reset to default, active low. Drive low to reset unit to default settings.	Input	Active 56K to 122K	
GND	37	Signal Ground			
EXT_RESET#	38	Unit hardware reset, active low. Drive low to reboot unit.	Input	10K	
GND	39	Signal Ground			
GND	40	Signal Ground			

Table 2-4 xPico Wi-Fi PCB Interface Signals

Signal Name	xPico Pin #	Primary Function	Reset State	Internal Pull-up /Pull-down	Driver Strength
GND	1	Signal Ground			
GND	2	Signal Ground			
CP8/SPI_CS ¹	3	Configurable I/O/ SPI Chip Select	Input, floating	30K to 50K	8mA
LED1/WLAN_LED	4	WLAN Link, active low	Input, floating	30K to 50K	8mA
RTS1 ⁷	5	Serial ready to send/ serial transmit enable	Input, floating	30K to 50K	8mA
NC	6	No Connect			
RXD1	7	Serial receive data input 1	Input, floating	30K to 50K	
NC	8	No Connect			
GND	9	Signal Ground			
TXD1	10	Serial transmit data output 1	Input,	30K to 50K	8mA

Signal Name	xPico Pin #	Primary Function	Reset State	Internal Pull-up /Pull-down	Driver Strength
			floating		
NC	11	No Connect			
NC	12	No Connect			
NC	13	No Connect			
WKUP ⁴	14	System Wake Up on Rising Edge	Input, floating	30K to 50K	
GND	15	Signal Ground			
CTS1 ⁷	16	Serial Clear to Send	Input, floating	30K to 50K	
NC	17	No Connect			
NC	18	No Connect			
NC	19	No Connect			
SYSTEM_LED	20	System status LED, active high	Input, floating	30K to 50K	8mA
GND	21	Signal Ground			
DDP ²	22	USB (positive)			
RXD2	23	Serial receive data input 2	Input, floating	30K to 50K	
DDM ²	24	USB Negative			
TXD2	25	Serial transmit data output 2	Input, floating	30K to 50K	8mA
CP2/INT ¹	26	Configurable I/O-External interrupt input	Input, floating	30K to 50K	8mA
CP7/SPI_SCK ¹	27	Configurable I/O/ SPI Clock	Input, floating	30K to 50K	8mA
CP3/MISO ¹	28	Configurable I/O/SPI Master In-Slave Out	Input, floating	30K to 50K	8mA
3V3	29	3.3V Input Power			
CP4/MOSI ¹	30	Configurable I/O/ SPI Master Out-Slave In	Input, floating	30K to 50K	8mA
3V3	31	3.3V Input Power			
CP5	32	Configurable I/O	Input, floating	30K to 50K	8mA
3V3	33	3.3V Input Power			
CP6	34	Configurable I/O	Input, floating	30K to 50K	8mA
CP1	35	Configurable I/O	Input, floating	30K to 50K	8mA
DEFAULT#	36	Unit reset to default, active low. Drive low to reset unit to	Input, floating	30K to 50K	

Signal Name	xPico Pin #	Primary Function	Reset State	Internal Pull-up /Pull-down	Driver Strength
		default settings.			
GND	37	Signal Ground			
EXT_RESET#	38	Unit hardware reset, active low. Drive low to reboot unit.	Input	30K to 50K	
GND	39	Signal Ground			
GND	40	Signal Ground			

Note 1: The xPico Wi-Fi SPI interface supports master only. Slave mode operation will be supported in a future firmware release.

Note 2: The xPico Wi-Fi USB interface is USB 2.0 full speed device. The device interface connector and power interface must be designed into the mating board.

Note 3: xPico and xPico Wi-Fi *embedded device servers* may be designed into the same socket. Signals listed as no connect on xPico Wi-Fi *embedded device server* may be connected on an xPico base design board. For example, xPico Wi-Fi pins 11, 12, 13, 17, 18, and 19 may connect to an Ethernet magnetic module as designed for xPico (wired), however, Ethernet will not be available on those pins for xPico Wi-Fi.

Note 4: Pin 14 is the Ethernet duplex LED output on xPico (wired) and the system wakeup input on xPico Wi-Fi. For board designs supporting both xPico (wired) and xPico Wi-Fi, a zero ohm resistor or removable jumper stuff option should be used to disconnect any on-board logic driving pin 14 when xPico (wired) unit is installed.

Note 5: The CP pins can be configured as pull-up or pull-down. The WKUP pin is not configurable and is always pull-down.

Note 6: The IO pins on xPico Wi-Fi *embedded device server* are configured as floating-input on reset until configured by firmware. For applications requiring a high signal on power up, an external pull-up may be required or removeable jumper.

Note 7: It is highly recommended to connect RTS and CTS for serial port 1.

Note: For integration information for Lantronix xPico Wi-Fi SMT embedded device server modules, XPC W1002 and XPC W1003 please reference the 900-714 xPico Wi-Fi SMT Integration Guide.

Mating Connector

The mating connector for the xPico and xPico Wi-Fi module is Hirose part number DF40C (2.0)-40DS-0.4V (51). Special care must be taken when mating and unmating the module to the mating connector. Refer to the Hirose DF40 data sheet below for proper connector mating and unmating, along with the proper connector footprint.

Mating connector data sheet: http://www.hirose.co.jp/cataloge_hp/e68440018.pdf

Antenna Interface (xPico Wi-Fi Units Only)

The xPico Wi-Fi module has been certified using the external antennas listed below. Per FCC guidelines, the xPico Wi-Fi certification remains valid if using an antenna of similar type to the antennas below. If using an antenna of similar type to one of the antennas below, but from a different manufacturer part number the antenna gain must be equal to or less than specified in the table. Consult with your certification lab for more details.

Table 2-5 xPico Wi-Fi External Antenna Options

Antenna Type	Peak Gain Typical	Lantronix Part Number	Vendor	Vendor Part Number
PCB Strip Antenna with 50mm cable to U.FL connector With tape backing	1.5 to 2.5dBi, 2.39 Ghz to 2.49 Ghz	XPW100A003-01-B (50 piece bulk pack)	Ethertronics®	1001077

Antenna Type	Peak Gain Typical	Lantronix Part Number	Vendor	Vendor Part Number
PCB Strip Antenna with 50mm cable to U.FL connector Without tape backing	1.5 to 2.5dBi, 2.39 Ghz to 2.49 Ghz		Ethertronics	1000668
Swivel type antenna, with RP-SMA(M) connector	2 dBi, 2.4 Ghz to 2.5 Ghz, 2 dBi, 5.15 Ghz to 5.85 Ghz	930-033-R-ACC (50 piece bulk pack)	Wanshih	WSS002

Note: The PCB strip antenna is available from Ethertronics, Inc. with or without adhesive tape backing for mounting to a plastic case. For the component without tape backing a non-conductive double sided adhesive tape can be used to fix the antenna in place. The Ethertronics part numbers listed above come with a 50mm U.FL cable attached to the PCB strip antenna. The 50mm cable length is the minimum allowed cable length for use with the xPico Wi-Fi embedded device server. For similar PCB strip antennas with longer cables consult with Ethertronics, Inc. (www.ethertronics.com).

Lantronix provides a U.FL to Reverse SMA antenna cable in with the evaluation board and sample kits for development work. These cables can be purchased from Lantronix for production or supplied by an RF cable manufacturer. External antennas can be purchased from the antenna vendor. Components for cable design should be selected for low loss over the entire 2.4Ghz to 5.9Ghz signal range. The cable target impedance should be 50 ohms.

Figure 2-4 Reverse-SMA to U.FL(long) (Lantronix Part Number 500-180-R)

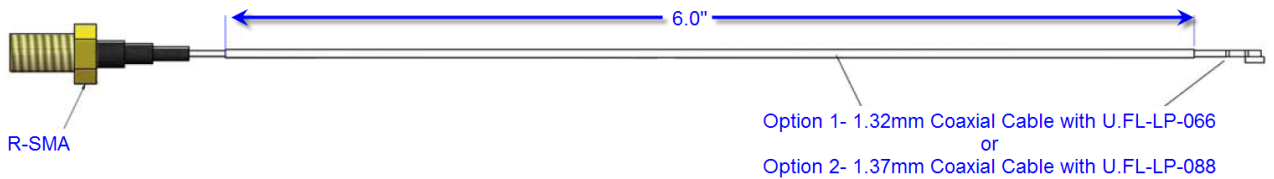

Figure 2-5 U.FL to U.FL Cable (Lantronix Part Number 500-181-R)

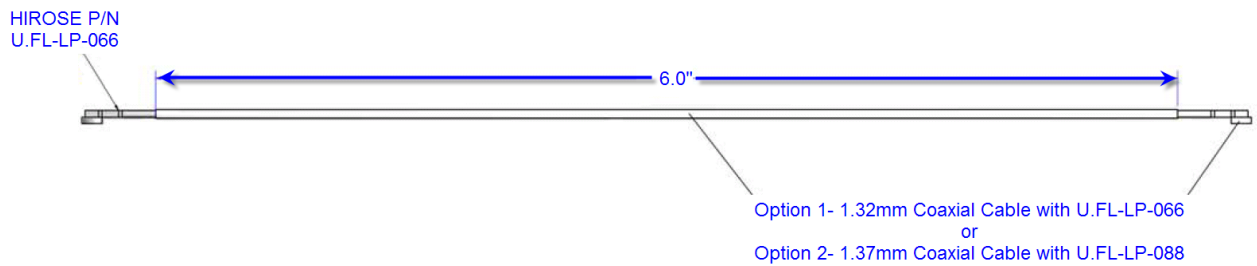
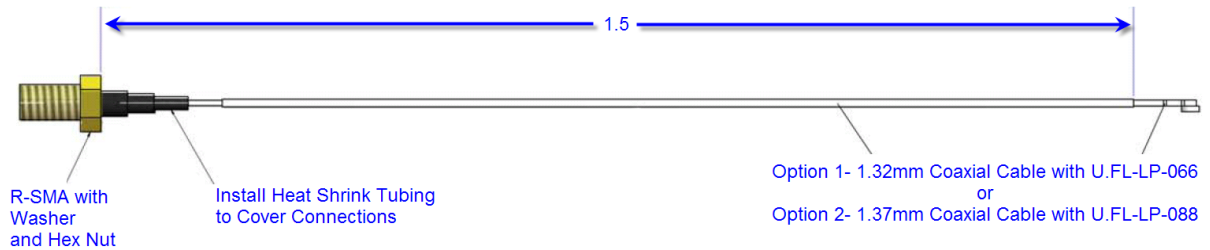

Figure 2-6 Reverse-SMA to U.FL(short) (Lantronix Part Number 500-182-R)

Antenna Placement (xPico Wi-Fi Units Only)

When designing the xPico Wi-Fi module to a mating board, it is important to consider the final installation of the unit and its location with respect to connecting access points. The antenna should be placed so that it has as clear as possible path to the connecting access point for maximum range. Avoid placing the antenna such that it is blocked by metal walls or ground planes of adjacent circuit boards.

Ethernet Interface (xPico Wired Units Only)

The xPico embedded device server integrates an internal 10/100Mbps Ethernet MAC and PHY. An external magnetic module and RJ45 is required in order to connect to a standard 10/100Mbps Ethernet network.

Table 2-6 Ethernet Interface Signals

Signal Name	DIR	Contact	Primary Function	Signal Requirement
TX+	Out	13	Differential Ethernet transmit data +	100 ohm differential with TX-
TX-	Out	11	Differential Ethernet transmit data -	100 ohm differential with TX+
RX+	In	19	Differential Ethernet receive data +	100 ohm differential with RX-
RX-	In	17	Differential Ethernet receive data -	100 ohm differential with RX+
TCT		12	Ethernet transmit center tap connection	Route > 20 mil width
RCT		18	Ethernet receive center tap connection	Route > 20 mil width

The xPico embedded device server provides a 10/100 Mbps Ethernet interface for connection to an external network through external magnetics and an external RJ45. The table below lists several magnetic modules and combination RJ45/magnetic jacks that can be used with the xPico unit.

**Table 2-7 Recommended Magnetic Modules
and Combo RJ45/Magnetic Module Connectors**

Type	Manufacturer	Part Number
Magnetic only (requires RJ45)	BI-Tech	HS91-011-80LFTR
Magnetic only (requires RJ45)	Mingtek	HN0013SG
Combination RJ45/Magnetic	Belfuse	08B0-1D1T-06-F
Combination RJ45/Magnetic	Midcom	MIC2411D-0117T-LF3
Magnetic for POE	PULSE	HX2019

The Ethernet differential pair signals, ERX-/ERX+ and ETX-/ETX+ should be routed as 100-ohm differential pairs on a layer next to the signal ground plane. The use of vias on these signals should be minimized. The center tap signal connections between the magnetic and xPico (wired) module are required. Center tap signals RCT and TCT should be routed with at least 20 mil trace thickness. The area between the magnetic module and RJ45 jack, including the area under both, should be voided of all signals and planes, except for the signals connecting to both. The signals connecting between the RJ45 and magnetic are required to be isolated by 1500Vrms from all other signals and planes, including chassis and signal ground. The connector shield should be connected to chassis. It is recommended that 1206 resistor pads from chassis ground to signal ground be placed next to each of the shield tabs. The resistor pads allow for 0 ohm jumper, ferrite beads, or decoupling caps to be installed as needed for EMI/EMC improvement.

The Ethernet LED signals should be routed to discrete LEDs or to the LED pins on the RJ45 through 220 ohm or larger resistors. The LED signals are active low. The Ethernet LED signals should be isolated from the signals that connect between the RJ45 and magnetic module.

Also shown in the reference schematic is a recommended TVS array that can be used to improve ESD and EFT in harsh environments. The device shown is Semtec RClamp0502A. This device features route through pin assignments allowing for the Ethernet differential signal pairs to be routed without altering the trace impedance or adding vias. Due to this routing, the device could be installed or depopulated as needed.

See the Lantronix app note, **How to Connect a Lantronix Embedded Module to a Wired Ethernet Port** for more details on Ethernet connection and routing, http://www.lantronix.com/pdf/appnotes/Connect-LTRX-Embed-Module-to-Wired-Ethernet_AN.pdf.

The xPico module can also be powered from POE using a POE magnetic and POE powered device controller. Lantronix uses the Silabs, Si3402 POE controller to power the xPico development board via POE. If using POE the Ethernet magnetic module should be changed to a POE compatible module such as Pulse HX2019.

Refer to the evaluation board schematic in the xPico-DevKit_UG for an example circuit. http://www.lantronix.com/pdf/xPico-DevKit_UG.pdf.

Refer to the SiLabs data sheet for Si3402 for more information on using the SiLabs POE controller.

Figure 2-7 Ethernet Connection Example (xPico wired unit only)

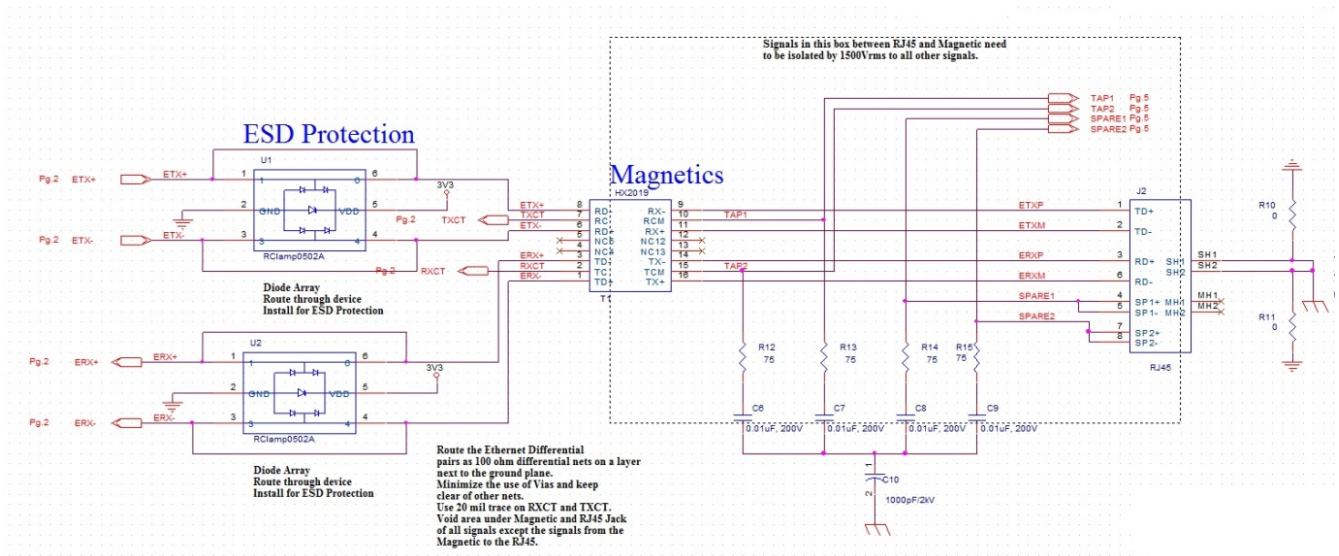

Serial Interface

The xPico and xPico Wi-Fi embedded device servers have two external serial interfaces. The signal levels on the serial interface are 3.3V logic level with 5V tolerant inputs. The serial interfaces require an external transceiver in order to connect to external RS232, RS485, or RS422 networks. The signals of Serial Port 1 may be connected as shown in the reference schematic, [Figure 2-8](#) serial port example, below. The transceiver shown in the reference schematic is of type Exar, part number SP336. This transceiver is a multiprotocol RS232, RS485, RS422 transceiver. Single protocol transceivers may be used as required. The xPico interface may also be directly connected to the UART interface of an external CPU. Serial Port 2 is a three wire interface only. It operates like Serial Port 1, except it does not support hardware Flow Control (i.e. no RTS/CTS) and modem control (i.e. no DTR/DCD). It is highly recommended to connect RTS and CTS for serial port 1.

Table 2-8 xPico and xPico Wi-Fi Serial Port Signals

Signal	Pin	Description	Reset State
TXD1	10	Serial Transmit Data output	Output
RTS1	5	Serial Ready-to-Send / Serial Transmit enable	Output
RXD1	7	Serial Receive Data input	Input
CTS1	16	Serial Clear-to-Send	Input
TXD2	25	Serial Transmit Data output 2	Output
RXD2	23	Serial Receive Data input 2	Input

Figure 2-8 Serial Port Example

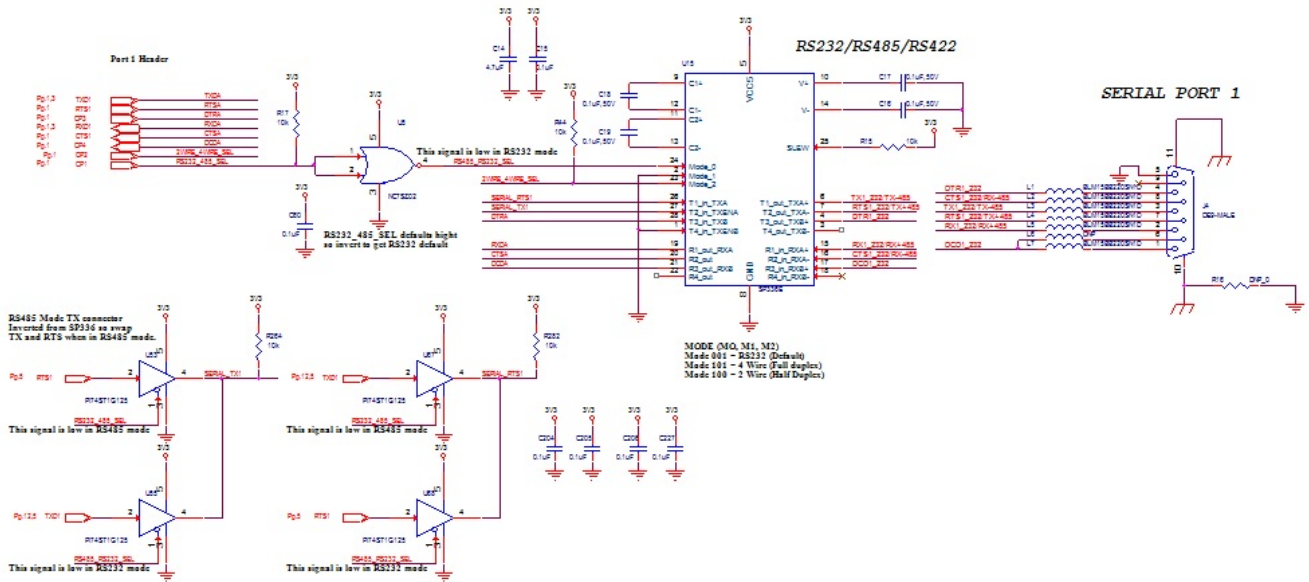

Table 2-9 RS232 Connections (Serial Transceiver Required)

xPico Signal		DCE Connector			DTE Connector		
Signal (Logic)	Description	DB9	DB25	Signal	DB9	DB25	Signal
RXDx	Data In	2	3	RXDx	3	2	TXDx
TXDx	Data Out	3	2	TXDx	2	3	RXDx
RTSx	H/W Flow Control Output	7	4	RTSx	8	5	CTSx
CTSx	H/W Flow Control Input	8	5	CTSx	7	4	RTSx
CPx	Modem Control Input	1	8	DCDx	4	20	DTRx
CPy	Modem Control Output	4	20	DTRx	1	8	DCDx

Table 2-10 RS422/485 Connections (Serial Transceiver Required)

xPico Signal (logic)	Description	RS485 Signal	DB25 4 Wire	DB25 2 Wire	DB9 4 wire	DB9 2 wire
TXDx	Data Out	TX+485	14	14	7	7
TXDx	Data Out	TX-485	15	15	3	3
RXDx	Data In	RX+485	21	14	2	7
RXDx	Data In	RX-485	22	15	8	3
RTSx	TX Enable					
CPx	RS485 Select					
CPy	RS485 2-wire					

Note: The IO pins for xPico Wi-Fi embedded device server are set to floating input on power up until configured by unit firmware. An external 100K ohm pull-up may be required on the serial transmit signal to prevent downstream UART devices from detecting false characters on initial power up.

USB Device Port (xPico Wi-Fi Units Only)

The xPico Wi-Fi embedded device server has one USB2.0 Full Speed Device port interfaces for connection to an upstream USB device. The port consists of a differential pair, signals DDP and DDM. These signals should be routed as a 90 ohm differential pair on a signal layer next to the signal ground plane. The use of vias should be minimized on these signals. The USB signals can be connected to a USB Mini Type B USB port (as shown in [Table 2-12](#)) directly to an IC with a USB host port. If connecting to an external port that is user accessible it is recommended to add a TVS diode array to the signal nets for ESD protection. The ESD array shown in the figure is of type Semtech RClamp0502A. This device features through pin routing to minimize trace impedance changes and simplify routing. The footprint for the TVS array can be added to the PCB and the part can be depopulated if it is not needed. It is recommended that the power drawn off the USB Mini Type B connector be limited to less than 500mA per USB requirements. If the USB device port is unused the DDP and DDM pins may be left unconnected.

Table 2-11 USB Host Port Signals

Pin Name	Description	Connector Pins	Signal Requirement	Mini Type B USB Device connector pin
DDP	USB Device Port Positive pin	22	Route as 90 ohm differential pair with DDM signal	3
DDM	USB Device Port Negative pin	24	Route as 90 ohm differential pair with DDP signal	2
5V	5V power from USB cable		Current limit to 500 mA per port	1
Ground	Signal Ground	Ground	Ground plane	5

Figure 2-9 USB Device Interface Example (xPico Wi-Fi unit only)

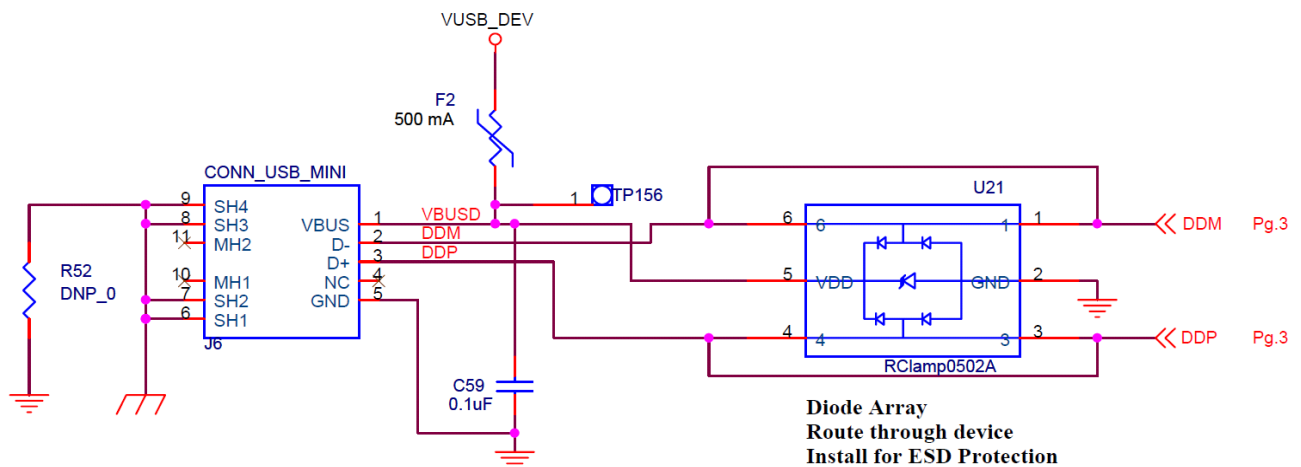

LEDs

The xPico embedded device server contains several external signals that are intended to drive external status LEDs. The LEDs are listed below. The signals may be connected as shown in the reference schematic figure below.

Note: The System LED usually remains **on**. When the **Default** button is pressed for 5-6 seconds, the System LED starts blinking every second to indicate the default button can be released to complete resetting the unit to factory default. The unit reboots after release of the **Default** button. A lit WLAN LED indicates the STA interface is associated with an access point.

Table 2-12 xPico Wi-Fi Status LED Output Signals

Signal	Pin	Description
LED1/WI-FI LED	4	WI-FI Status LED, active low
SYSTEM_LED	20	System status LED, active high

Table 2-13 xPico Status LED Output Signals

Signal	Pin	Description
LED0/SPEED	6	Ethernet speed LED, active low
LED1/LINK	4	Ethernet Link LED, active low
LED2/ACTIVITY	8	Ethernet Activity LED, active low
LED3/DUPLEX	14	Ethernet Duplex LED, active low
SYSTEM_LED	20	System status LED, active high

General Purpose I/O Pins

xPico and xPico Wi-Fi unit contains eight pins which may be used as configurable inputs or outputs. Listed below are the configurable I/O pins. These pins are 3.3V CMOS logic level and 5V input tolerant.

Table 2-14 Ethernet Interface xPico Serial Port Signals

Signal	Pin	Description for xPico Wired	Description xPico Wi-Fi	Reset State
CP1	35	Configurable I/O	Configurable I/O	Input
CP2/INT	26	Configurable I/O-External interrupt input	Configurable I/O-SPI interrupt input	Input
CP3	28	Configurable I/O	Configurable I/O-SPI MISO	Input
CP4	30	Configurable I/O	Configurable I/O-SPI MOSI	Input
CP5	32	Configurable I/O	Configurable I/O	Input
CP6	34	Configurable I/O	Configurable I/O	Input
CP7	27	Configurable I/O	Configurable I/O-SPI Clock	Input
CP8	3	Configurable I/O	Configurable I/O-SPI Chip Select	Input

Note 1. For xPico Wi-Fi 5V tolerant pins, in order to sustain a voltage higher than $V_{CC}+0.3$, the internal pull-up/ pull-down resistors must be disabled.

Reset Pins

The xPico and xPico Wi-Fi embedded device servers have two signals for use as reset signals. Signal EXT_RESET# is a hardware controlled input signal that will reboot the xPico processor when asserted low. Signal DEFAULT# is polled by the xPico software. When DEFAULT# is asserted low for six seconds, the unit will reset the system to the default manufacturing settings and reboot the unit. xPico Wi-Fi embedded device server has an additional signal on pin 14 that can be used to wake up the unit processor when the unit is in a sleep or power down state.

Table 2-15 xPico Reset Signals

Signal	Pin	Description	Reset State	Internal pull-up
EXT_RESET#	38	Unit hardware reset, active low. Assert low for a minimum of 50 milliseconds, then release to reboot unit. Signal may be left floating.	Input	10K (xPico unit) 40K (xPico Wi-Fi unit)
DEFAULT#	36	Unit reset to default, active low. <ul style="list-style-type: none"> • For wired xPico units Drive low and reboot the device to reset unit to factory defaults. • For xPico Wi-Fi units While device is running, drive low for greater than 6 seconds, then release to reset unit to factory defaults. While device is held in reset, drive low, release reset to boot device with Line 1 CLI default settings (original configuration is preserved), then release after CLI session is established. 	Input	Active 56K to 122K (xPico unit) 40K (xPico Wi-Fi unit)
WAKE (xPico Wi-Fi unit only)	14	Toggle signal from low to high can wake device from Sleep or Standby mode. Hold low to allow device to enter Sleep or Standby mode. Subject to configuration settings.	Input	40K

Evaluation Board Schematics

Figure 2-10 Evaluation Board Schematic, Part 1 of 5

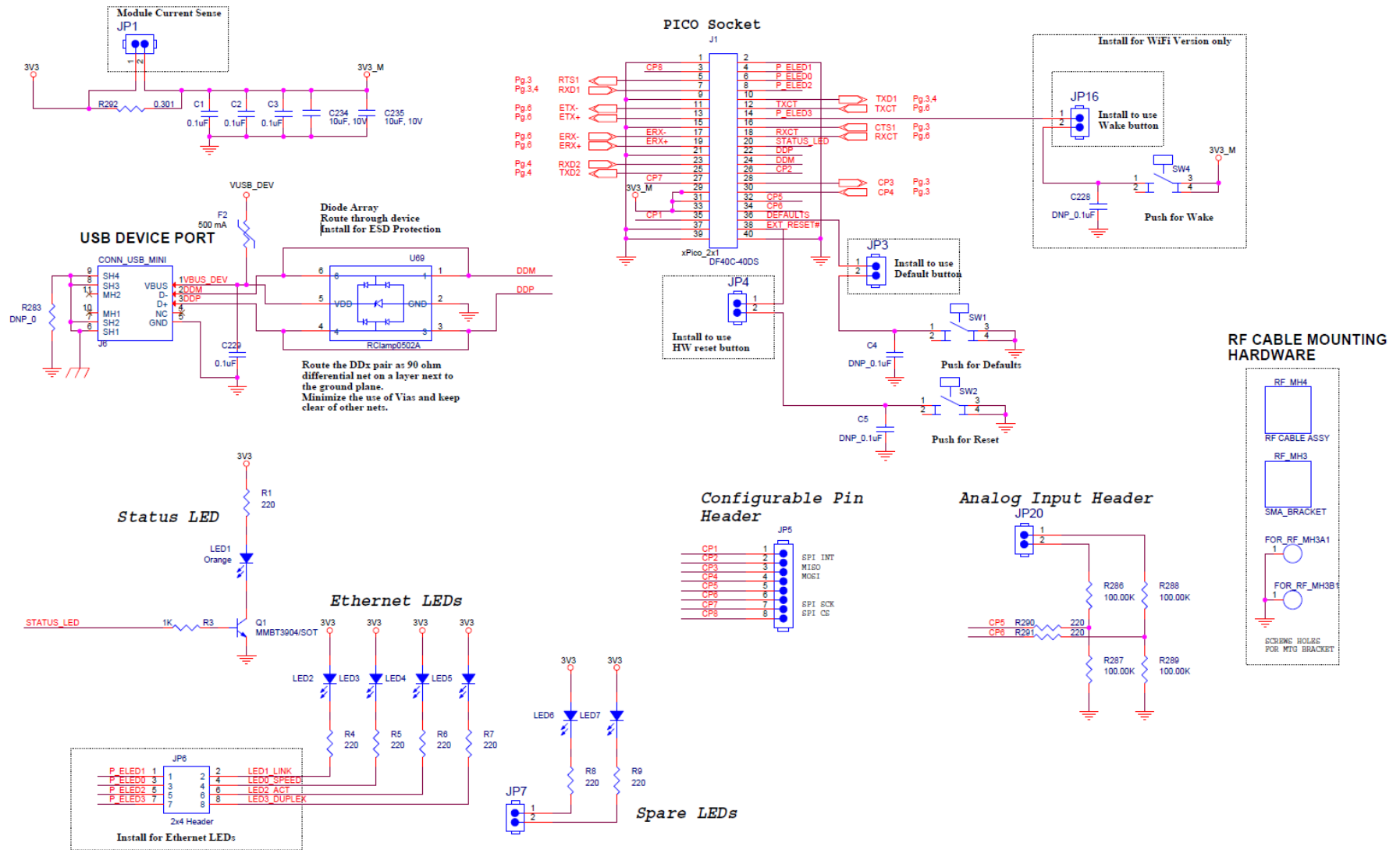

Figure 2-11 Evaluation Board Schematic, Part 2 of 5

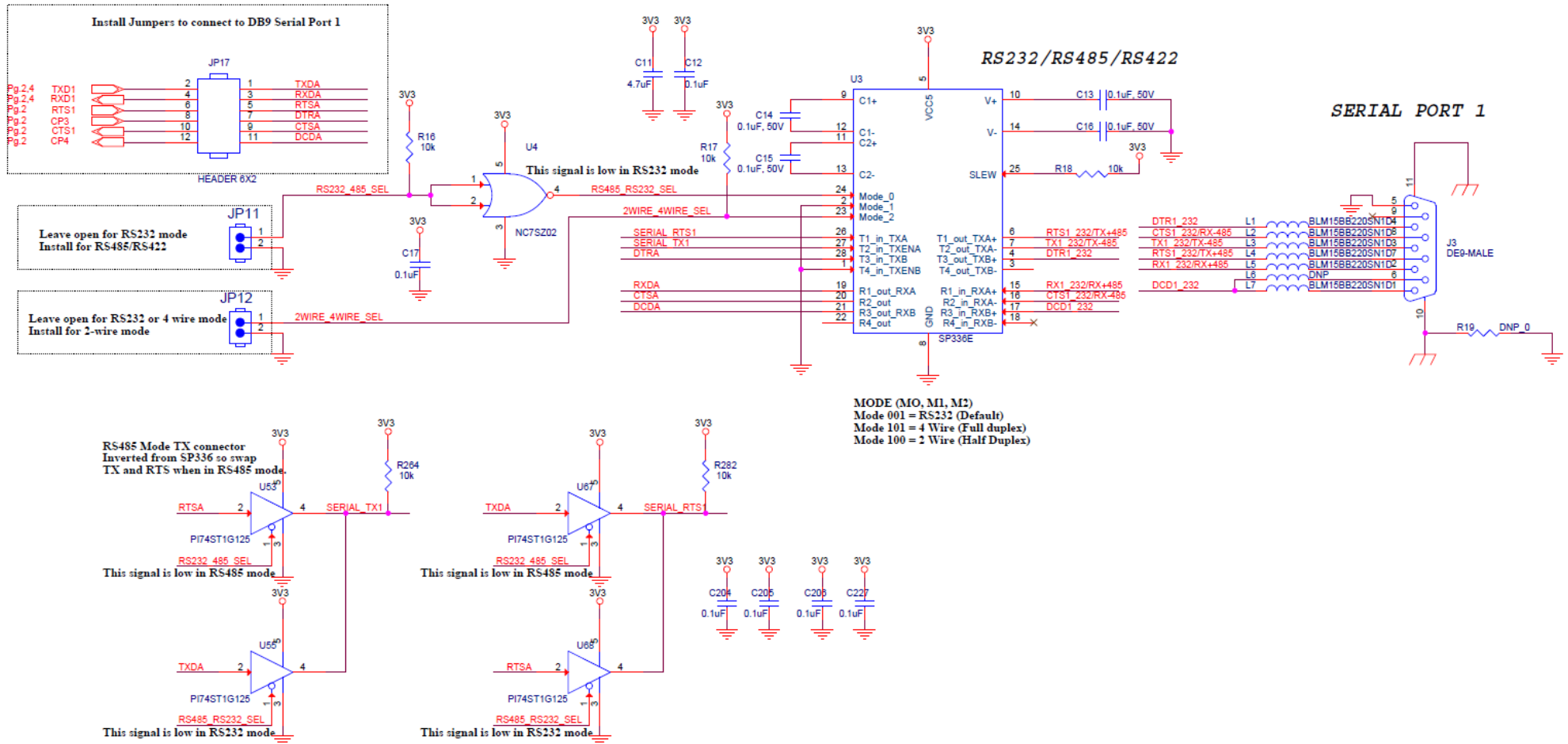

Figure 2-12 Evaluation Board Schematic, Part 3 of 5

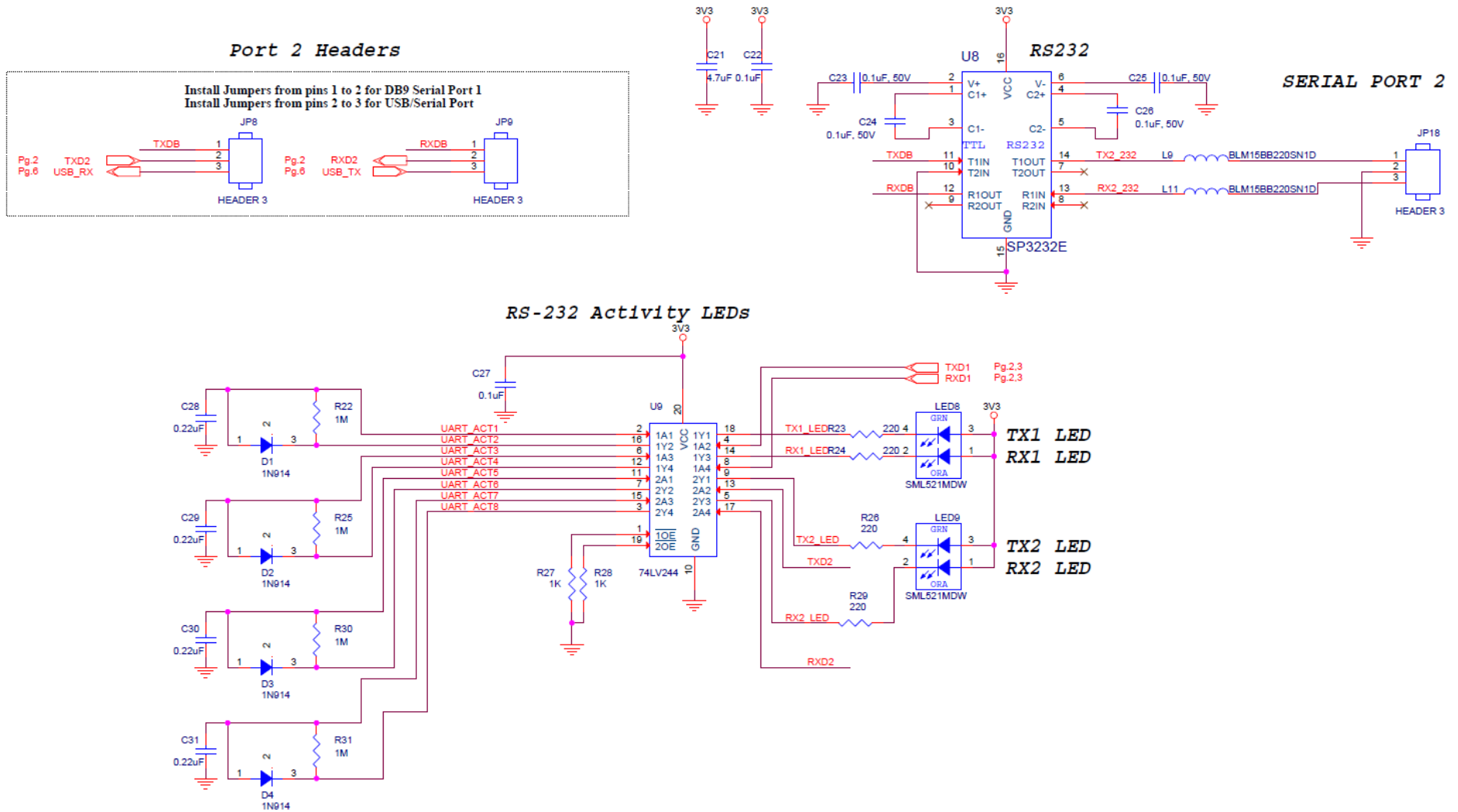

Figure 2-13 Evaluation Board Schematic, Part 4 of 5

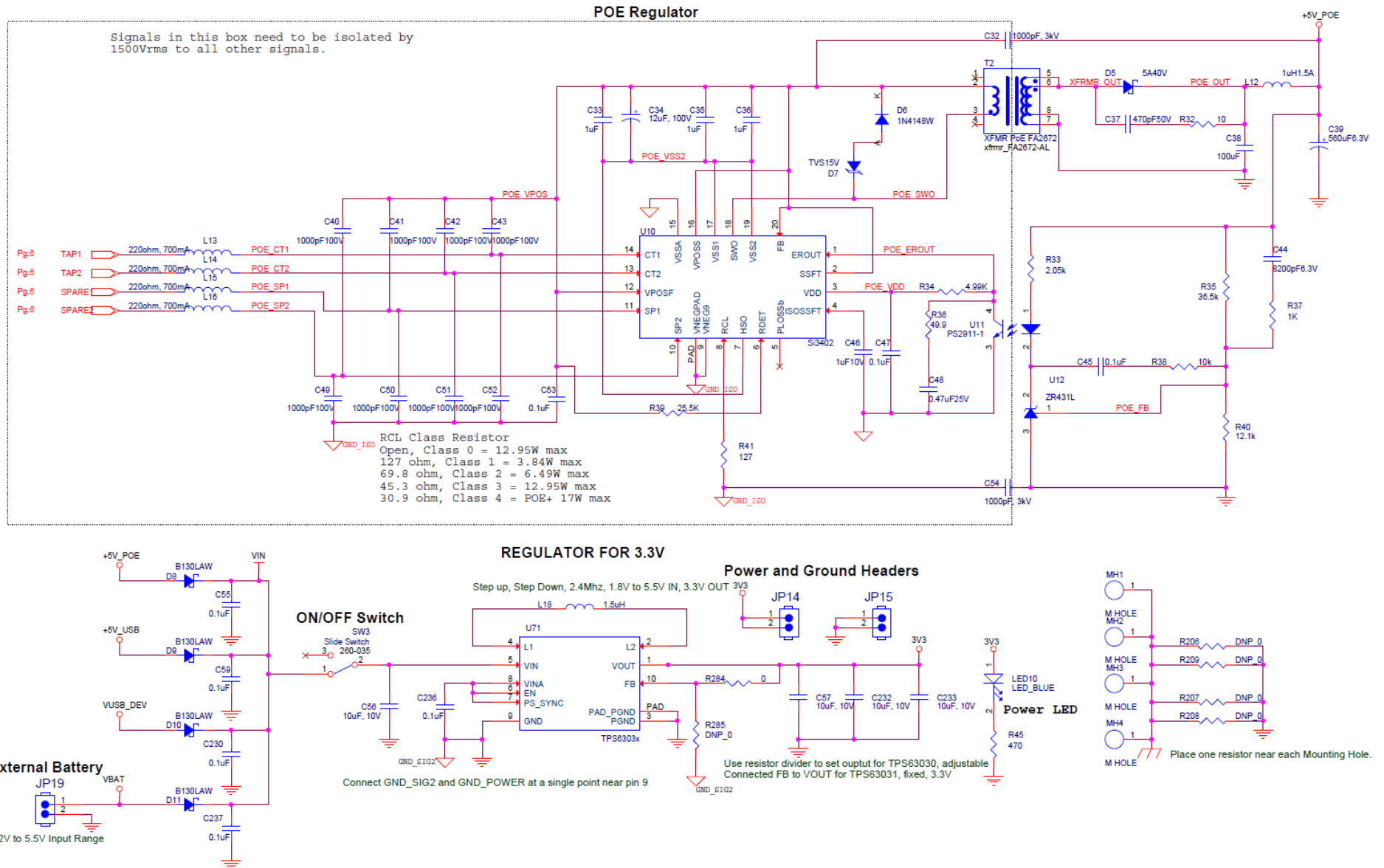
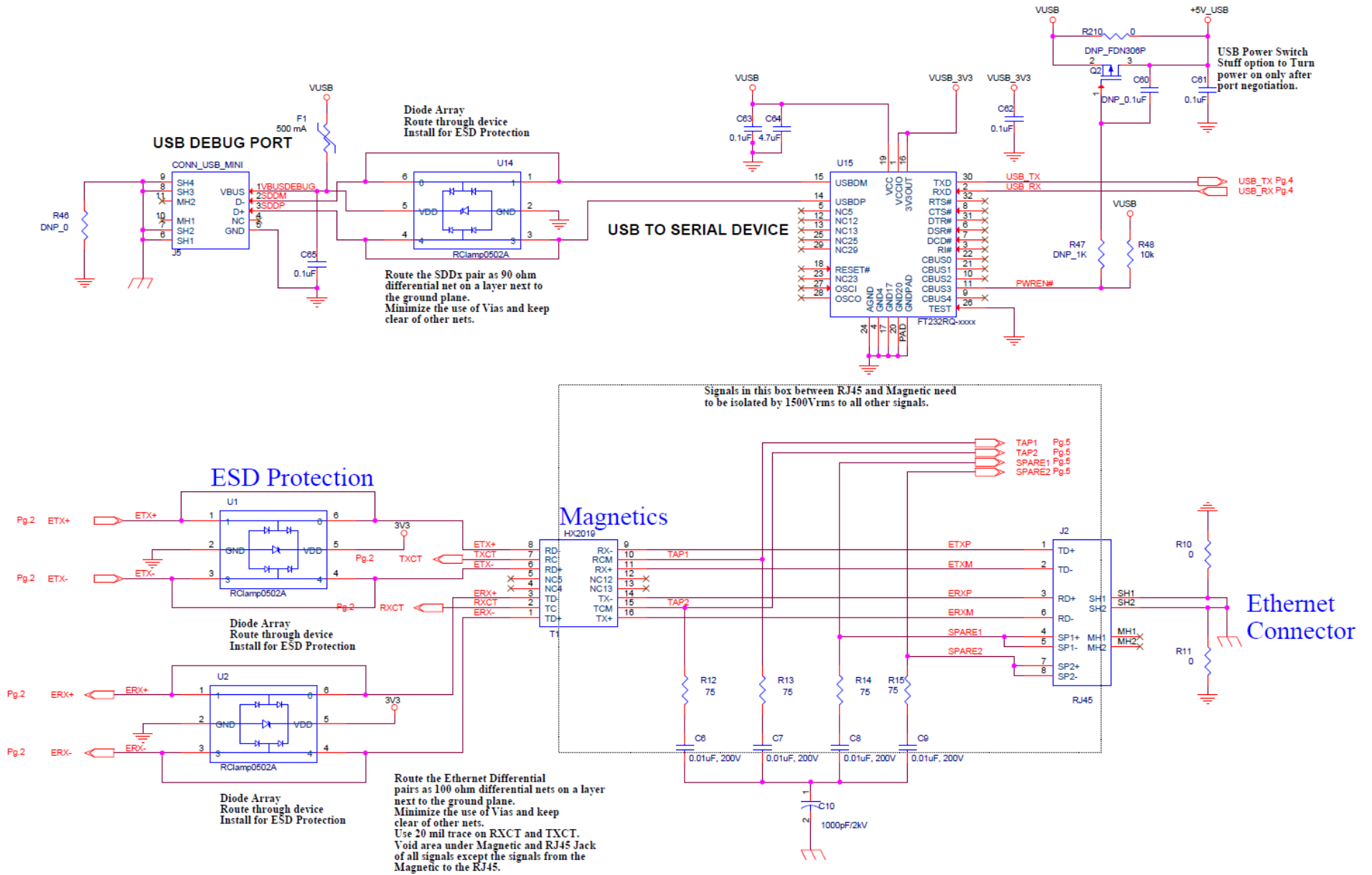

Figure 2-14 Evaluation Board Schematic, Part 5 of 5



3. Mounting Instructions and PCB Footprint

The xPico embedded device server dimensions and mounting instructions are shown in the following drawings below. You may also directly access the CAD files through the Lantronix website.

Note: The mounting instructions in this section are applicable to both the xPico and the xPico Wi-Fi embedded device servers though the xPico pictures below are used to demonstrate installation.

For temperature environments up to +85° Celsius, it is recommended that the mating PCB have its outer layers flooded with signal ground and a heat pad be placed between the module and mating PCB. The recommended heat pad is Lantronix part number XPC100A002-01-B. The ground flooding and heat pad are only required for xPico Wi-Fi units in environments above +70°C. For environments below +70°C the heat pad and ground flooding are not required.

To Access CAD Files

1. Go to <http://www.lantronix.com/products/cad-visio.html>.
2. Click **Download CAD files here** to access the **Registration Form**.

Figure 3-1 White Mounting Quick Clip Dimensions

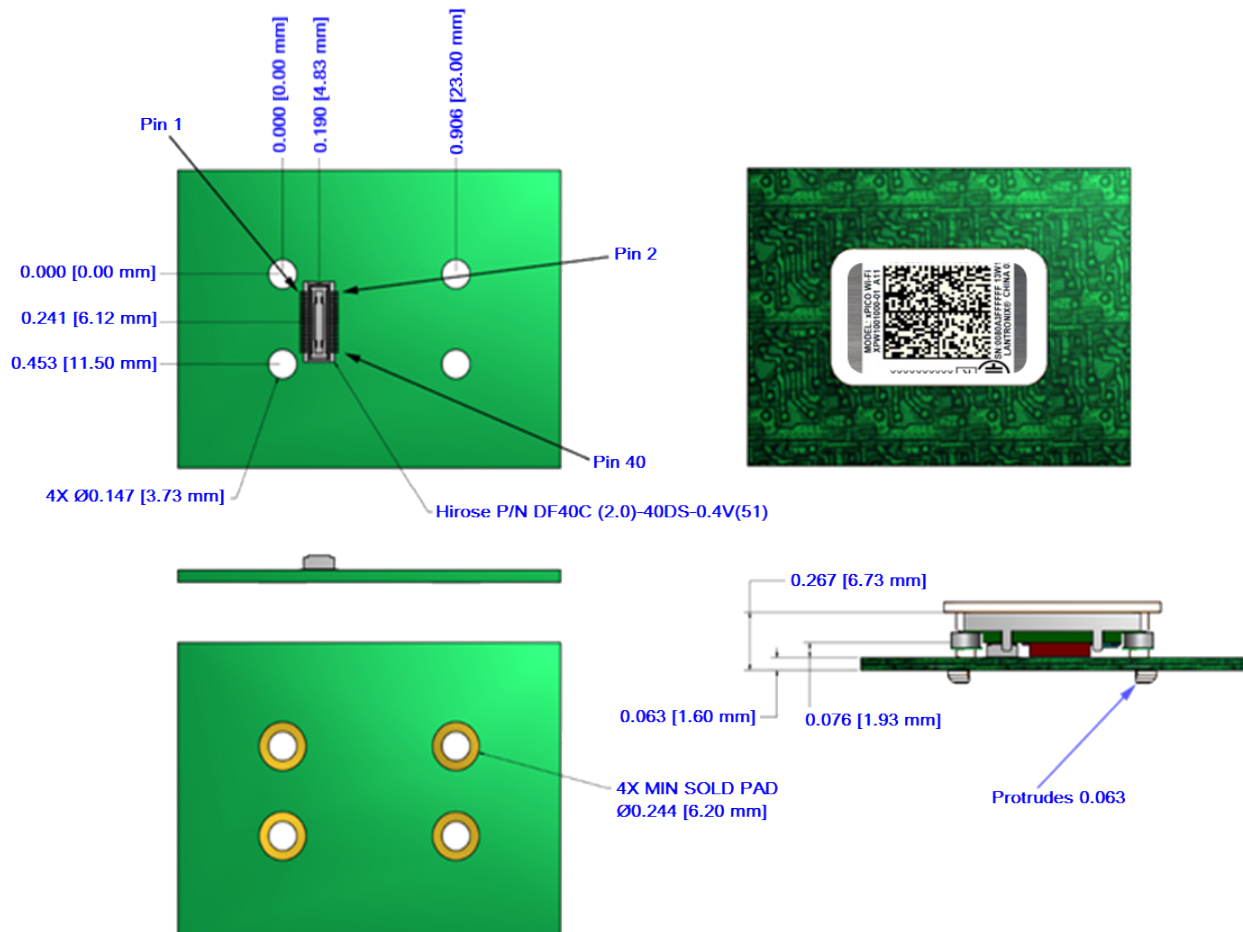

To Install the xPico or xPico Wi-Fi Module

In the xPico embedded device server development kit (part number XPC100100K-02) and xPico Wi-Fi development kit (XPW100100K-01), the xPico module comes installed to the xPico Evaluation Board via the connector J1 (Hirose component). If ordered separately, you may need to install it by following the directions below. The included white Mounting Quick Clip is used to align and fasten the module to the evaluation board.

1. Place the module into the white mounting clip, lining up the clip legs and the four module grooves so that the module is seated inside the white clip. For xPico Wi-Fi unit connect the RF cable to the module U.FL connector prior to installing the Quick Clip.



2. Push the legs of the white clip inward to secure the module to the clip.



3. Flip over the module/mounting clip combination so that the product label displays on top and the white mounting clip legs are pointed downward.
4. For xPico Wi-Fi embedded device server high temperature operation, above +70C, it is recommended to place a heat pad between the module and the adjacent PCB. The recommended heat pad is Lantronix part number XPC100A002-01-B (available in a 50 piece bulk pack).
5. Place the module/mounting clip combination so that the four mounting clip legs align with the four standoff holes on the board surrounding the J1 connector (see [Figure 3-2](#)). Make sure to properly orientate the module/mounting clip combination on the board, so that the J1 connector/Hirose component is properly aligned.

Figure 3-2 Aligning Mounting Clip Legs to Standoff Holes

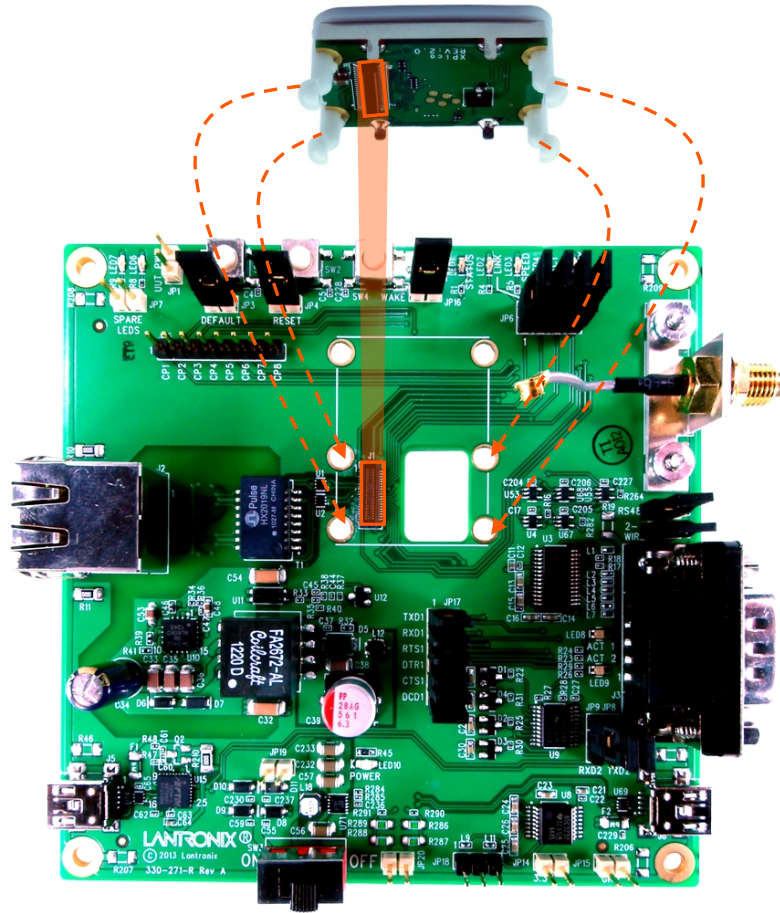

6. Insert the white clip legs furthest from the J1 connector first and gently push down on the xPico module above the J1 connector. Keep the module as level as possible during installation.

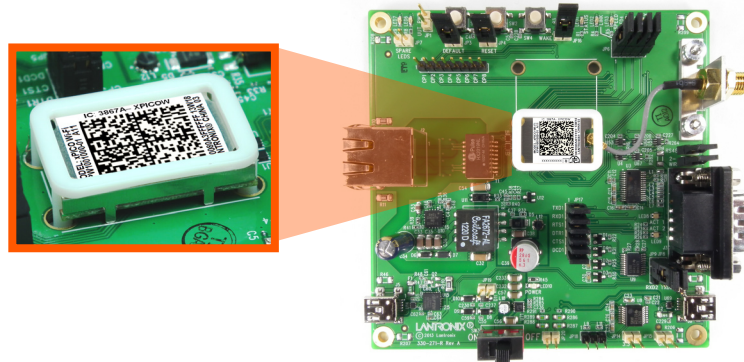

Note: When removing the xPico embedded device server from the evaluation board, gently tug the module. Do not use excessive force or attempt to remove the xPico module by grasping and pulling the module from the short end opposite the module connector as this may cause damage to the J1 evaluation board connector.

Figure 3-3 Mounting Instructions for PEM Standoff

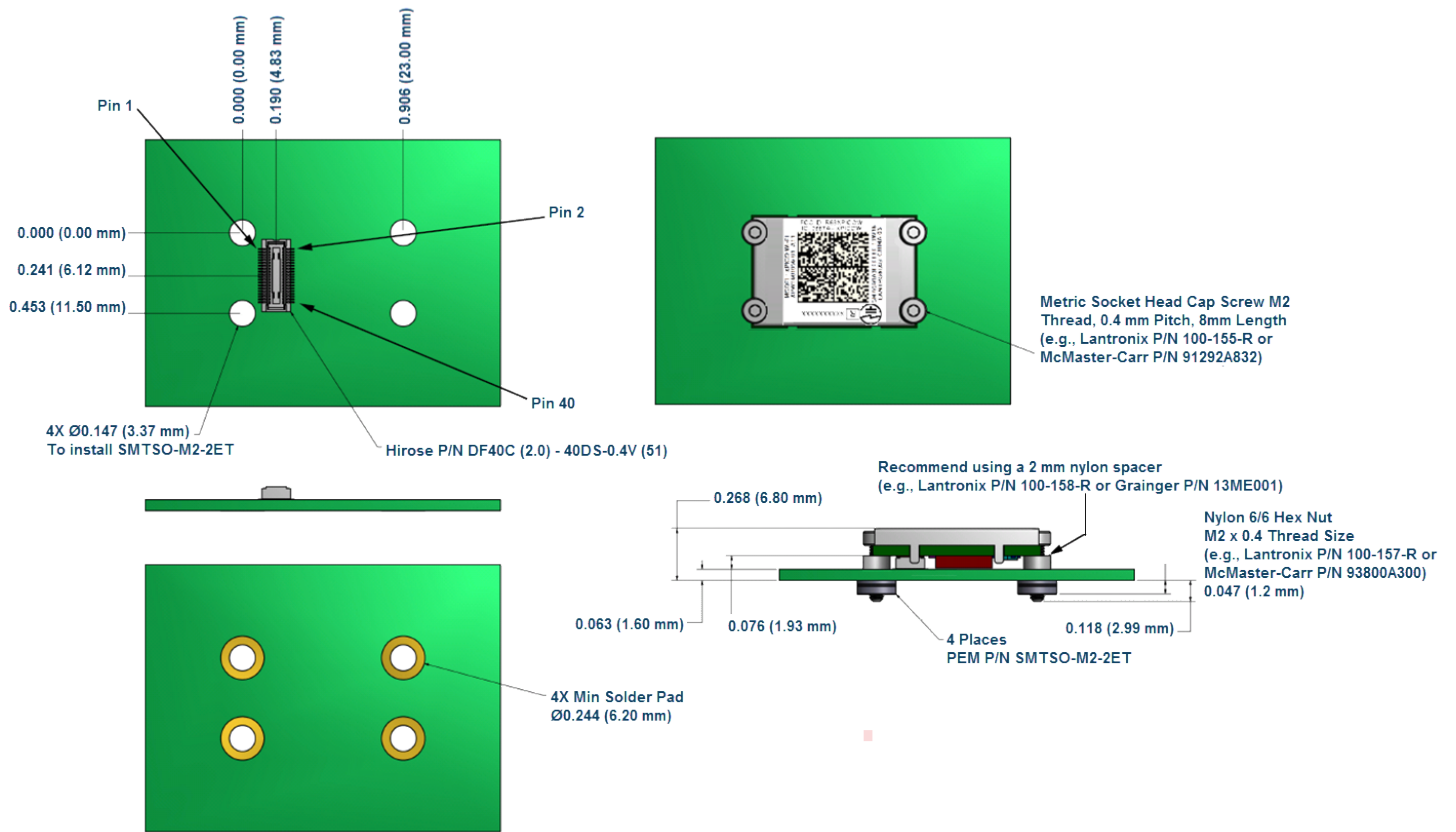
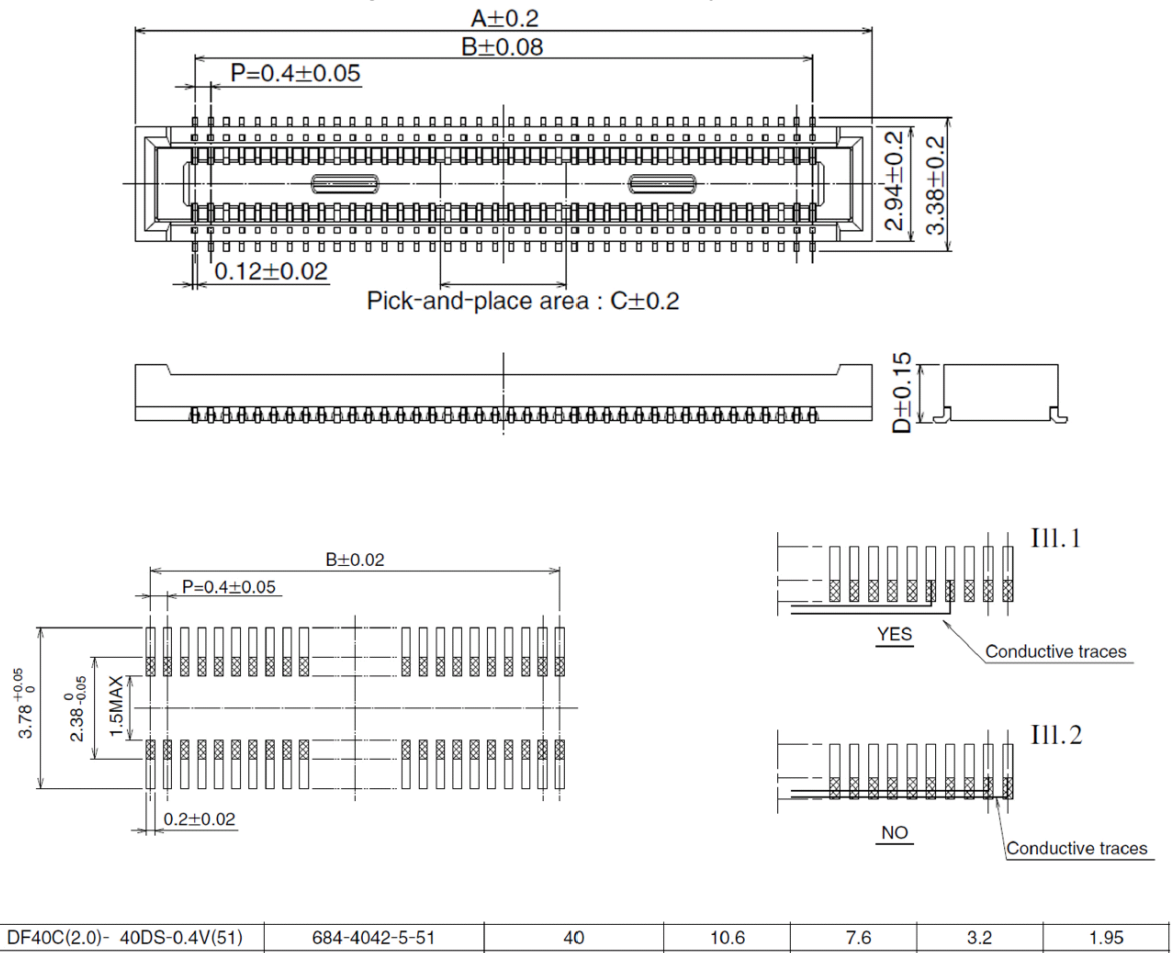

Figure 3-4 Hirose Connector Layout



Product Information Label

The product information label contains important information about your specific unit, such as its part number, revision, manufacturing date code, product model, country of origin, datamatrix barcode and MAC address.

Figure 3-5 xPico Product Label

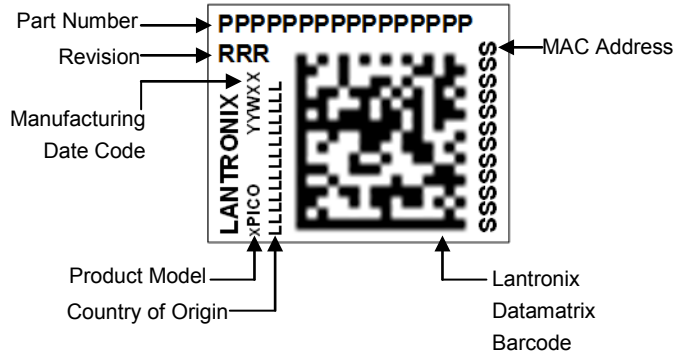
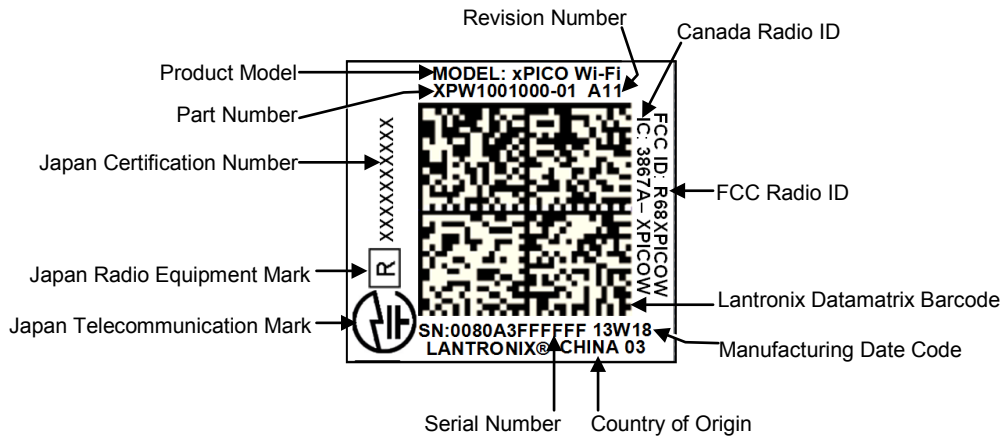

Figure 3-6 xPico Wi-Fi Product Label



4. Specifications

Electrical Specifications

Caution: Stressing the device above the rating listed in this table may cause permanent damage to the xPico embedded device server. Exposure to Absolute Maximum Rating conditions for extended periods may affect the xPico unit's reliability. For xPico Wi-Fi operation above +70° Celsius, it is recommended that a heat pad be placed between the module and mating PCB.

Table 4-1 Absolute Maximum Ratings

Parameter	Symbol	Min	Max	Units
Supply Voltage	V _{CC}	0	3.6	Vdc
Operating Temperature		-40	85	°C
Storage Temperature		-40	85	°C

Table 4-2 xPico Wired Recommended Operating Conditions

Parameter	Symbol	Min	Typical	Max	Units
Supply Voltage	V _{CC}	3.15	3.3	3.46	Vdc
Supply Voltage Ripples	V _{CC_PP}			2	%
100 BaseTX Active (Normal CPU Speed)	I _{CC}		200		mA
10 BaseT Active (Normal CPU Speed)	I _{CC}		220		mA
No Link (Normal CPU Speed)	I _{CC}		150		mA
100 BaseTX Active (High CPU Speed)	I _{CC}		240		mA
10 BaseT Active (High CPU Speed)	I _{CC}		260		mA
No Link (High CPU Speed)	I _{CC}		190		mA
100 BaseTX Active (Low CPU Speed)	I _{CC}		170		mA
10 BaseT Active (Low CPU Speed)	I _{CC}		190		mA
No Link (Low CPU Speed)	I _{CC}		120		mA
Supply Reset Threshold	V _{RST}	2.7			Vdc
CPx Pull-ups, except CP5, CP6	R _{PU}	56		122	Kohm
CP5,CP6 Pull-up	R _{PU}		10		Kohm
CPx, RX Input Low Voltage	V _{CP_IL}			0.8	Vdc
CPx, RX Input High Voltage	V _{CP_IH}	2		5.5	Vdc
CPx, TX Output Low Voltage (I _{OL} = 4 mA)	V _{CP_OL}			0.4	Vdc
CPx, TX Output High Voltage (I _{OH} = -4 mA)	V _{CP_OH}	2.4			Vdc
Reset Pin Low Voltage	V _{RES_IL}			0.36	Vdc
Reset Pin High Voltage	V _{RES_IH}	2.0		3.46	Vdc

Table 4-3 xPico Wi-Fi Recommended Operating Conditions

Parameter	Symbol	Min	Typical	Max	Units
Supply Voltage	V _{CC}	3.15	3.3	3.46	Vdc
Supply Voltage Ripples	V _{CC_PP}			2	%
TX Power @ 16.5dBm, 802.11b, 11Mbps	I _{CC}		330	380	mA
TX Power @ 15dBm, 802.11g, 6Mbps	I _{CC}		300	345	mA
TX Power @ 13dBm, 802.11g, 54Mbps	I _{CC}		255	295	mA
TX Power @ 14.5dBm, 802.11n, MCS0	I _{CC}		290	335	mA
TX Power @ 12dBm, 802.11n, MCS7	I _{CC}		230	265	mA
RX Power @ 802.11b, 11Mbps	I _{CC}		125	150	mA
RX Power @ 802.11g, 54Mbps	I _{CC}		125	150	mA
RX Power @ 802.11n, MCS7	I _{CC}		125	150	mA
Power Management State 1 @ 25°C	I _{CC}		6		μA
Power Management State 1 @ +85°C	I _{CC}		12		μA
Power Management State 1 @ -40°C	I _{CC}		5		μA
Supply Reset Threshold	V _{RST}				Vdc
CPx Pull-ups/ Pull-downs	R _{PU}	30	40	50	Kohm
CPx, RX Input Low Voltage	V _{CP_IL}	-0.3		0.75	Vdc
CPx, RX ⁽¹⁾ Input High Voltage	V _{CP_IH}	2		5.5	Vdc
CPx, TX Output Low Voltage (I _{OL} = 4 mA)	V _{CP_OL}			0.4	Vdc
CPx, TX Output High Voltage (I _{OH} = -4 mA)	V _{CP_OH}	2.4			Vdc
Reset Pin Low Voltage	V _{RES_IL}	-0.3		0.8	Vdc
Reset Pin High Voltage	V _{RES_IL}	2		V _{CC} +0.3	Vdc

Note 1. For xPico Wi-Fi 5V tolerant pins, in order to sustain a voltage higher than V_{CC}+0.3, the internal pull-up/pull-down resistors must be disabled.

Technical Specifications

Table 4-4 xPico Wired Technical Specification

Category	Description
CPU, Memory	Lantronix DSTni-EX 186 CPU, 256-Kbyte zero wait state SRAM, 512-Kbyte flash, 16-Kbyte boot ROM
Firmware	Upgradeable via TFTP and serial port
Reset Circuit	Internal 200ms power-up reset pulse. Power-drop reset triggered at 2.6V. External reset input causes an internal 200ms reset.
Serial Interface	CMOS (Asynchronous) 3.3V-level signals Rate is software selectable: 300 bps to 921600 bps
Serial Line Formats	Data bits: 7 or 8 Stop bits: 1 or 2 Parity: odd, even, none
Modem Control	DTR/DCD, CTS, RTS <- Serial 1 only
Flow Control	Serial 1: XON/XOFF (software), CTS/RTS (hardware) Serial 2: XON/XOFF (software)
Programmable I/O	8 PIO pins (software selectable), sink or source 4mA max.
Network Interface	10/100Mbps Ethernet, requires external magnetics and RJ45
Compatibility	Ethernet: Version 2.0/IEEE 802.3 (electrical), Ethernet II frame type
Protocols Supported	ARP, UDP/IP, TCP/IP, Telnet, ICMP, SNMP, DHCP, BOOTP, TFTP, Auto IP, SMTP, and HTTP
LEDs	Link, Activity, Link Speed, Duplex, System Status logic level outputs
Management	Internal web server, SNMP (read only) Serial login, Telnet login
Security	Password protection, locking features, optional Rijndael 256-bit encryption
Internal Web Server	Serves static Web pages and Java applets Storage capacity: 384 Kbytes
Weight	2.5 grams
Material	Metal shell
Temperature	Operating range: -40°C to +85°C (-40°F to 185°F)
Warranty	For details on the Lantronix warranty policy, go to our web site at www.lantronix.com/support/warranty .
Included Software	Windows 98/NT/2000/XP-based Lantronix® DeviceInstaller™ configuration software and Windows based Com Port Redirector
EMI Compliance	See A:Compliance .

Table 4-5 xPico Wi-Fi Technical Specification

Category	Description
CPU, Memory	Cortex M3 CPU, 1MB Flash, 128KB+4KB SRAM, Additional 1MB on board Flash
Firmware	Upgradeable via TFTP and serial port
WLAN Standards	802.11 b/g/n Wireless LAN with external antenna
Antenna Connector	U.FL connector for external antenna
Frequency Band	2.400Ghz to 2.484Ghz
Channel Support	Channel 1 to Channel 14
Modulation	DSSS, CCK, OFDM, BPSK, QPSK, 16QAM, 64QAM
Protocols Supported	ARP, UDP/IP, TCP/IP, Telnet, ICMP, SNMP, DHCP, BOOTP, TFTP, Auto IP, SMTP, and HTTP
Data Rates 802.11b	1, 2, 5.5, 11 Mbps
Data Rates 802.11g	6, 9, 12, 18, 24, 36, 48, 54 Mbps
Data Rates 802.11n	HT20 MCS0 (6.5Mbps) to HT20 MCS7 (65Mbps)
802.11b, CCK Mode Average Output Power	16.5 +/- 1.5dBm Typical @ 25C
802.11g, OFDM Mode Average Output Power	15 +/- 1.5dBm, Typical @ 25C, 6Mbps 13 +/- 1.5dBm, Typical @ 25C, 54Mbps
802.11n, OFDM Mode Average Output Power	14.5 +/- 1.5dBm, Typical @ 25C, MCS0 12 +/- 1.5dBm, Typical @ 25C, MCS7
802.11b Average Output EVM	IEEE Spec -10dBm
802.11g Average Output EVM	IEEE Spec, -5dB @ 6Mbps IEEE Spec, -25dB @ 54Mbps
802.11n Average Output EVM	IEEE Spec, -5dB @ MCS0 IEEE Spec, -28dB @ MCS7
802.11b, PER <8% RX Sensitivity @ 1Mbps	-93dBm Typical -89dBm Min
802.11b, PER <8% RX Sensitivity @ 11Mbps	-88dBm Typical -84dBm Min
802.11g, PER <10% RX Sensitivity @ 6Mbps	-87dBm Typical -83dBm Min
802.11g, PER <10% RX Sensitivity @ 54Mbps	-74dBm Typical -70dBm Min
802.11n, PER <10% RX Sensitivity @ MCS0	-87dBm Typical -83dBm Min
802.11n, PER <10% RX Sensitivity @ MCS7	-71dBm Typical -67dBm Min
Serial Interface	CMOS (Asynchronous) 3.3V-level signals Rate is software selectable: 300 bps to 921600 bps
Serial Line Formats	Data bits: 7 or 8 Stop bits: 1 or 2 Parity: odd, even, none
Modem Control	DTR/DCD, CTS, RTS <- Serial 1 only
Flow Control	Serial 1: XON/XOFF (software), CTS/RTS (hardware) Serial 2: XON/XOFF (software)
Programmable I/O	8 PIO pins (software selectable), sink or source 4mA max.
LEDs	WLAN Status, System Status logic level outputs

Category	Description
Management	Internal web server, SNMP (read only) Serial login, Telnet login
Security	Password protection, locking features, optional Rijndael 256-bit encryption
Internal Web Server	Serves static Web pages and Java applets Storage capacity: TBD Kbytes
Weight	2.5 grams
Material	Metal shell
Temperature	Operating range: -40°C to +85°C (-40°F to 185°F) with use of heat pad between module and mating PCB
Warranty	For details on the Lantronix warranty policy, go to our web site at www.lantronix.com/support/warranty .
Included Software	Windows 98/NT/2000/XP-based DeviceInstaller configuration software and Windows based Com Port Redirector
EMI Compliance	See A: Compliance .

A: Compliance (xPico Embedded Device Server)

(According to ISO/IEC Guide 22 and EN 45014)

Manufacturer's Name & Address:

Lantronix, Inc. 7535 Irvine Center Drive, Suite 100, Irvine, CA 92618 USA

Declares that the following product:

Product Name Model: xPico® Embedded Device Server

Conforms to the following standards or other normative documents:

Electromagnetic Emissions/Immunity:



Table A-1 Electromagnetic Emissions

Test Description	Specification	Test Method
Radiated Emissions	EN 55022:2010 Class B	CISPR 22:2008
Radiated Emissions	FCC 15.109(g):2012 CISPR 22:1997 Class B	ANSI C63.4:2009
Conducted Emissions	EN 55022:2010 Class B	CISPR 22:2008
Conducted Emissions	FCC 15.109(g):2012 CISPR 22:1997 Class B	ANSI C63.4:2009

Table A-2 Electromagnetic Immunity

Test Description	Specification	Test Method	Performance Criteria
ESD	EN 55024:2010	IEC 61000-4-2:2008	2
Radiated Immunity	EN 55024:2010	IEC 61000-4-3:2010	1
EFT	EN 55024:2010	IEC 61000-4-4:2004 (Amended by A1:2010)	1
Surge	EN 55024:2010	IEC 61000-4-5:2005	1
Conducted Immunity	EN 55024:2010	IEC 61000-4-6:2008	1
Magnetic Field Immunity	EN 55024:2010	IEC 61000-4-8:2009	1
Voltage Interruptions	EN 55024:2010	IEC 61000-4-11:2004	3
Voltage Dips	EN 55024:2010	IEC 61000-4-11:2004	1

Figure A-1 Certificate of Compliance for Halogen Free

	167 Technology Drive Irvine CA 92618 USA Tel: 949-453-3990 Fax: 949-453-3995 www.lantronix.com
Date: September 15, 2014	
Certificate of Compliance: ISO 9001:2008 Design, Marketing and Sales of Machine to Machine Connectivity Hardware and Software, Halogen Free Product	
Lantronix Part Number: XPCW1002100* (xPico Wi-Fi Module, SMT, without On-Module Antenna) XPCW1003100* (xPico Wi-Fi Module, SMT, On-Module Antenna)	
Declared Product Weight: 1.5g	
This product is manufactured by an ISO 9001 certificated supplier.	
This product conforms to the specification in the Lantronix Data Sheet for this part number.	
Lantronix is committed to marketing environmentally friendly products. We work with our contract manufacturers and their suppliers to ensure that materials, components and processes comply with the appropriate directive regarding usage of hazardous substances. Based upon information provided by our supplier, to the best of our knowledge, all materials, components and processes used in the manufacture of the product listed above are in compliance with the following:	
<u>IEC 61249-2-21 Halogen Free Definition</u> Chlorine concentration \leq 900 ppm Bromine concentration \leq 900 ppm Total halogens concentration \leq 1500 ppm	
Lantronix hereby declares this part number is a HALOGEN FREE PRODUCT. Chlorine and Bromine are not intentionally added.	
 Gary Lok Environmental Substance & Process Compliance Program Manager Lantronix	 Daryl Baxa Manager of Test and Mfg. Engineering Lantronix
FM-342 Rev A	

Manufacturer's Contact:

Lantronix, Inc.
7535 Irvine Center Drive
Suite 100
Irvine, CA 92618 USA
Tel: (800) 526-8766
Tel: (949) 453-3990
Fax: (949) 453-3995